

AIR CONDITIONER

Wall mounted type

DESIGN & TECHNICAL MANUAL

INDOOR



ASYG07KGTA
ASYG09KGTA
ASYG12KGTA
ASYG14KGTA

OUTDOOR



AOYG07KGCA
AOYG09KGCA
AOYG12KGCA
AOYG14KGCA

FUJITSU GENERAL LIMITED

Notices:

- Product specifications and design are subject to change without notice for future improvement.
- For further details, please check with our authorized dealer.

Trademarks

FGLair™ is trademark of Fujitsu General Limited in the United States, other countries or both.

Google Play™ is trademark of Google Inc.

App Store® is a service mark of Apple Inc., registered in the U.S. and other countries.

CONTENTS

Part 1. INDOOR UNIT.....	1
1. Specifications	2
2. Dimensions	4
2-1. Models: ASYG07KGTA, ASYG09KGTA, ASYG12KGTA, and ASYG14KGTA.....	4
3. Wiring diagrams	6
3-1. Models: ASYG07KGTA, ASYG09KGTA, ASYG12KGTA, and ASYG14KGTA.....	6
4. Capacity table	7
4-1. Cooling capacity.....	7
4-2. Heating capacity	9
5. Fan performance	10
5-1. Air velocity distributions.....	10
5-2. Airflow	12
6. Operation noise (sound pressure).....	16
6-1. Noise level curve.....	16
6-2. Sound level check point	18
7. Safety devices	19
8. External input and output.....	20
8-1. External input.....	21
8-2. External output.....	22
8-3. Combination of external input and output.....	23
8-4. Details of function	25
9. Group connection	30
10. Remote controller	31
10-1. Wireless remote controller	31
11. Function settings	33
11-1. Function settings by using remote controller.....	33
11-2. Custom code setting for wireless remote controller.....	40
12. Accessories	41
12-1. Models: ASYG07KGTA, ASYG09KGTA, ASYG12KGTA, and ASYG14KGTA.....	41
13. Optional parts	42
13-1. Controllers	42
13-2. Others	42

CONTENTS (continued)

Part 2. OUTDOOR UNIT	43
1. Specifications	44
2. Dimensions	45
2-1. Models: AOYG07KGCA, AOYG09KGCA, AOYG12KGCA, and AOYG14KGCA.....	45
3. Installation space	46
3-1. Models: AOYG07KGCA, AOYG09KGCA, AOYG12KGCA, and AOYG14KGCA.....	46
4. Refrigerant circuit	49
4-1. Models: AOYG07KGCA, AOYG09KGCA, AOYG12KGCA, and AOYG14KGCA.....	49
5. Wiring diagrams	50
5-1. Models: AOYG07KGCA, AOYG09KGCA, AOYG12KGCA, and AOYG14KGCA.....	50
6. Capacity compensation rate for pipe length and height difference	51
6-1. Models: AOYG07KGCA, AOYG09KGCA, AOYG12KGCA, and AOYG14KGCA.....	51
7. Additional charge calculation	52
7-1. Models: AOYG07KGCA and AOYG09KGCA	52
7-2. Models: AOYG12KGCA and AOYG14KGCA	52
8. Airflow	53
8-1. Model: AOYG07KGCA.....	53
8-2. Model: AOYG09KGCA.....	53
8-3. Model: AOYG12KGCA.....	53
8-4. Model: AOYG14KGCA.....	54
9. Operation noise (sound pressure)	55
9-1. Noise level curve.....	55
9-2. Sound level check point	57
10. Electrical characteristics	58
11. Safety devices	59
12. Accessories	60
12-1. Models: AOYG07KGCA, AOYG09KGCA, AOYG12KGCA, and AOYG14KGCA.....	60

Part 1. INDOOR UNIT

WALL MOUNTED TYPE:

ASYG07KGTA

ASYG09KGTA

ASYG12KGTA

ASYG14KGTA

1. Specifications

Type				Wall mounted						
				Inverter heat pump						
Model name				ASYG07KGTA	ASYG09KGTA	ASYG12KGTA	ASYG14KGTA			
Power supply				230 V ~ 50 Hz						
Available voltage range				198—264 V						
Capacity	Cooling	Rated	kW	2.00	2.50	3.40	4.20			
			Btu/h	6,800	8,500	11,600	14,300			
		Min.—Max.	kW	0.9—3.2	0.9—3.4	0.9—4.1	0.9—4.5			
			Btu/h	3,100—10,900	3,100—11,600	3,100—14,000	3,100—15,400			
	Heating	Rated	kW	2.50	2.80	4.00	5.40			
			Btu/h	8,500	9,500	13,600	18,400			
		Min.—Max.	kW	0.9—5.2	0.9—5.4	0.9—6.1	0.9—6.4			
			Btu/h	3,100—17,700	3,100—18,400	3,100—20,800	3,100—21,800			
Input power	Cooling	Rated	kW	0.400	0.555	0.805	1.175			
				Min.—Max.	0.25—0.95	0.25—1.04	0.25—1.29	0.25—1.46		
	Heating	Rated	kW	0.500	0.560	0.910	1.350			
				Min.—Max.	0.25—1.58	0.25—1.72	0.25—1.89	0.25—2.06		
	Fan	HIGH	W	22.9	26.9	26.6	32.5			
				MED	15.8	16.9	17.3	19.6		
				LOW	10.8	10.8	11.8	12.5		
				QUIET	7.6	7.6	9.0	9.1		
	Current	Cooling	Rated	A	2.3	3.0	4.3	5.3		
					Heating	2.8	3.5	4.8	6.4	
EER	Cooling	kW/kW		5.00	4.50	4.22	3.57			
COP	Heating	kW/kW		5.00	5.00	4.40	4.00			
Sensible capacity	Cooling	kW		1.2	1.6	2.2	3.2			
Power factor	Cooling	%		76	80	81	96			
	Heating	%		78	70	82	92			
Moisture removal	L/h (pints/h)		1.0 (1.76)	1.3 (2.288)	1.8 (3.168)	2.1 (3.696)				
Maximum operating current *1	Cooling	A		6.5	6.5	9.0	9.0			
	Heating	A		9.0	9.0	9.0	10.5			
Fan	Airflow rate	Cooling	HIGH	650	700	700	770			
			MED	540	560	560	600			
			LOW	430	430	430	450			
			QUIET	270	270	250	280			
		Heating	HIGH	720	750	770	800			
			MED	580	610	640	660			
			LOW	460	470	520	520			
			QUIET	330	330	310	340			
	Type × Q'ty	Cross flow fan × 1								
	Motor output	W		22	24	27	30			
	Sound pressure level *2	Cooling	HIGH	dB (A)	38	40	40	43		
					MED	33	34	35	36	
LOW					29	29	30	30		
QUIET					19	19	19	20		
Heating		HIGH	dB (A)	41	42	42	44			
				MED	35	36	38	39		
				LOW	31	31	33	33		
				QUIET	21	21	21	24		
				Heat exchanger type	Dimensions (H × W × D)	mm	Main1: 210 × 670 × 26.6 Main2: 112 × 670 × 20		Main1: 210 × 670 × 26.6 Main2: 112 × 670 × 20 Sub: 84 × 670 × 13.3	
							Fin pitch	Man1: 1.2, Main2: 1.1		Man1: 1.2, Main2: 1.1, Sub: 1.4
Rows × Stages	Main1: 2 × 10, Main2: 2 × 7		Main1: 2 × 10, Main2: 2 × 7, Sub: 1 × 4							
Pipe type	Copper tube									
Fin type	Aluminum									
Enclosure	Material	Polystyrene								
	Color	White + Pearl white (painted) Approximate color of Munsell N 9.25/								
Dimensions (H × W × D)	Net	mm	270 × 834 × 215							
	Gross		277 × 914 × 332							
Weight	Net	kg	10.0							
	Gross		12.5		13.0					
Connection pipe	Size	Liquid	Ø 6.35 (Ø 1/4)							
		Gas	Ø 9.52 (Ø 3/8)							
	Method	Flare								
Drain hose	Material	PP+LLDPE								
	Size	Ø 13.8 (I.D.), Ø 15.8 to Ø 16.7 (O.D.)								
Operation range	Cooling	°C	18 to 32							
		%RH	80 or less							
	Heating	°C	16 to 30							
Remote controller type	Wireless (Wired, Mobile app*3 [FGLair™] [option])									

NOTES:

- Specifications are based on the following conditions:
 - Cooling: Indoor temperature of 27 °CDB/19 °CWB, and outdoor temperature of 35 °CDB/24 °CWB.
 - Heating: Indoor temperature of 20 °CDB/15 °CWB, and outdoor temperature of 7 °CDB/6 °CWB.
 - Pipe length: 5 m, Height difference: 0 m. (Between outdoor unit and indoor unit.)
- Protective function might work when using it outside the operation range.
- *1: Maximum current is maximum value when operated within the operation range.
- *2: Sound pressure level:
 - Measured values in manufacturer's anechoic chamber.
 - Because of the surrounding sound environment, the sound levels measured in actual installation conditions might be higher than the specified values here.
- *3: Available on Google Play™ store or on App Store®. Optional WLAN adapter is also required. For details, refer to the setting manual.

Model name			ASYG07KGTA	ASYG09KGTA	ASYG12KGTA	ASYG14KGTA	
Energy efficiency class	Cooling		A+++				
	Heating (Average)		A++				
Pdesign	Cooling	kW	2.0 (35 °C)	2.5 (35 °C)	3.4 (35 °C)	4.2 (35 °C)	
	Heating (Average)		2.3 (-10 °C)	2.4 (-10 °C)	2.5 (-10 °C)	4.0 (-10 °C)	
SEER	Cooling	kWh/kWh	8.52	8.52	8.51	7.11	
SCOP	Heating (Average)		5.12	5.11	5.10	4.31	
Annual energy consumption	QCE		82	103	140	207	
	QHE (Average)		628	658	685	1,298	
Sound power level	Cooling	HIGH	dB (A)	54	55	56	57
	Heating			56	57	58	59

2. Dimensions

2-1. Models: ASYG07KGTA, ASYG09KGTA, ASYG12KGTA, and ASYG14KGTA

Unit: mm

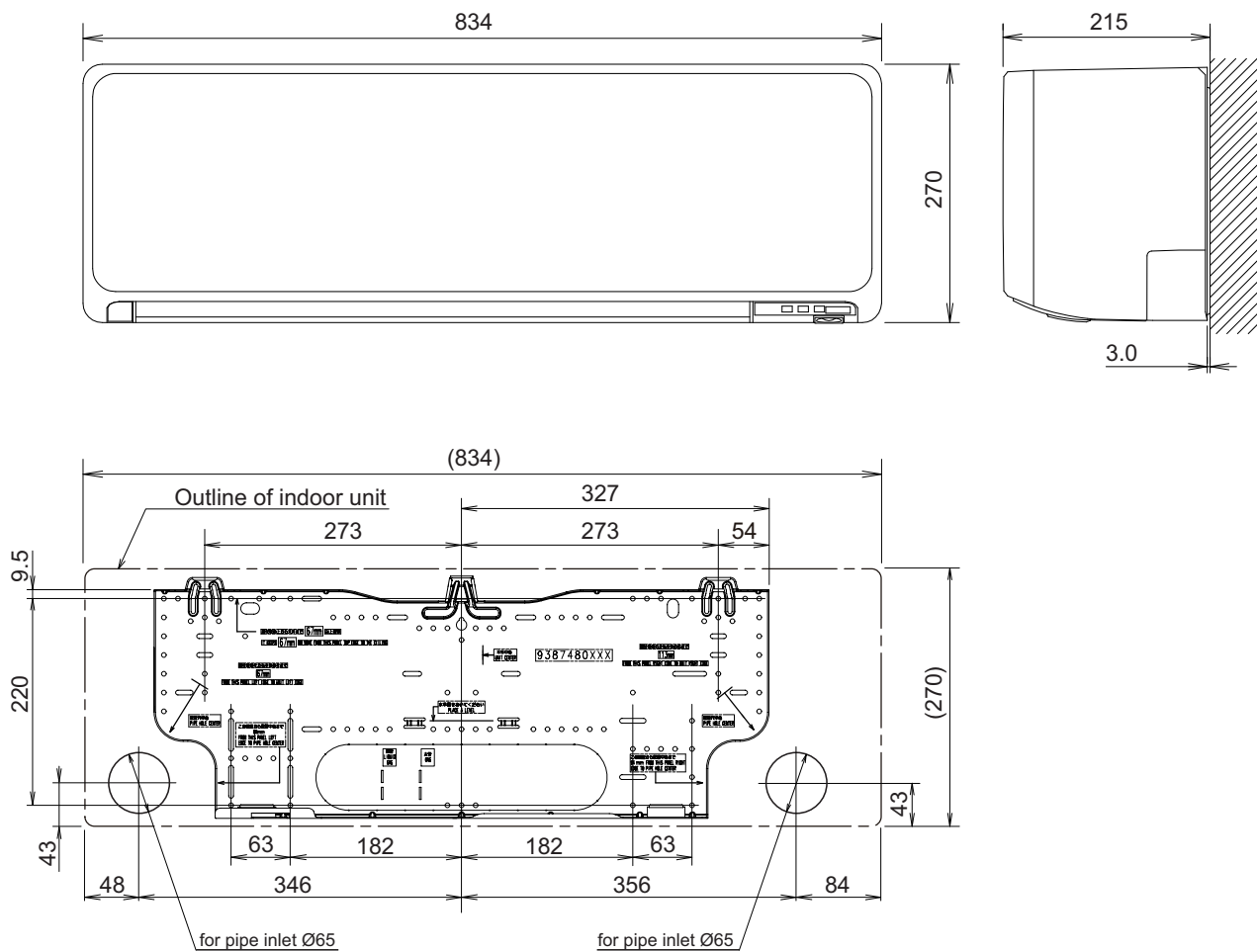

■ Installation space requirement

Provide sufficient installation space for product safety.

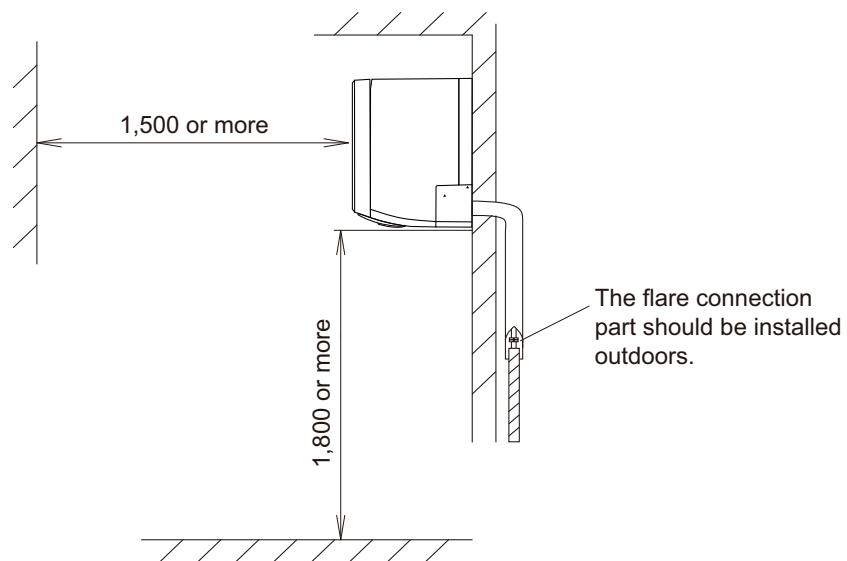
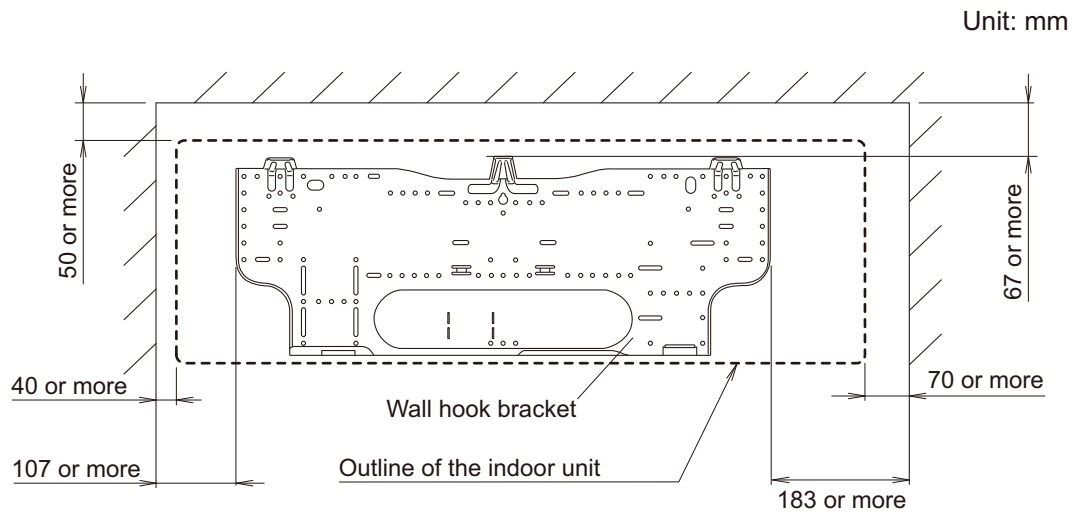

3. Wiring diagrams

3-1. Models: ASYG07KGTA, ASYG09KGTA, ASYG12KGTA, and ASYG14KGTA

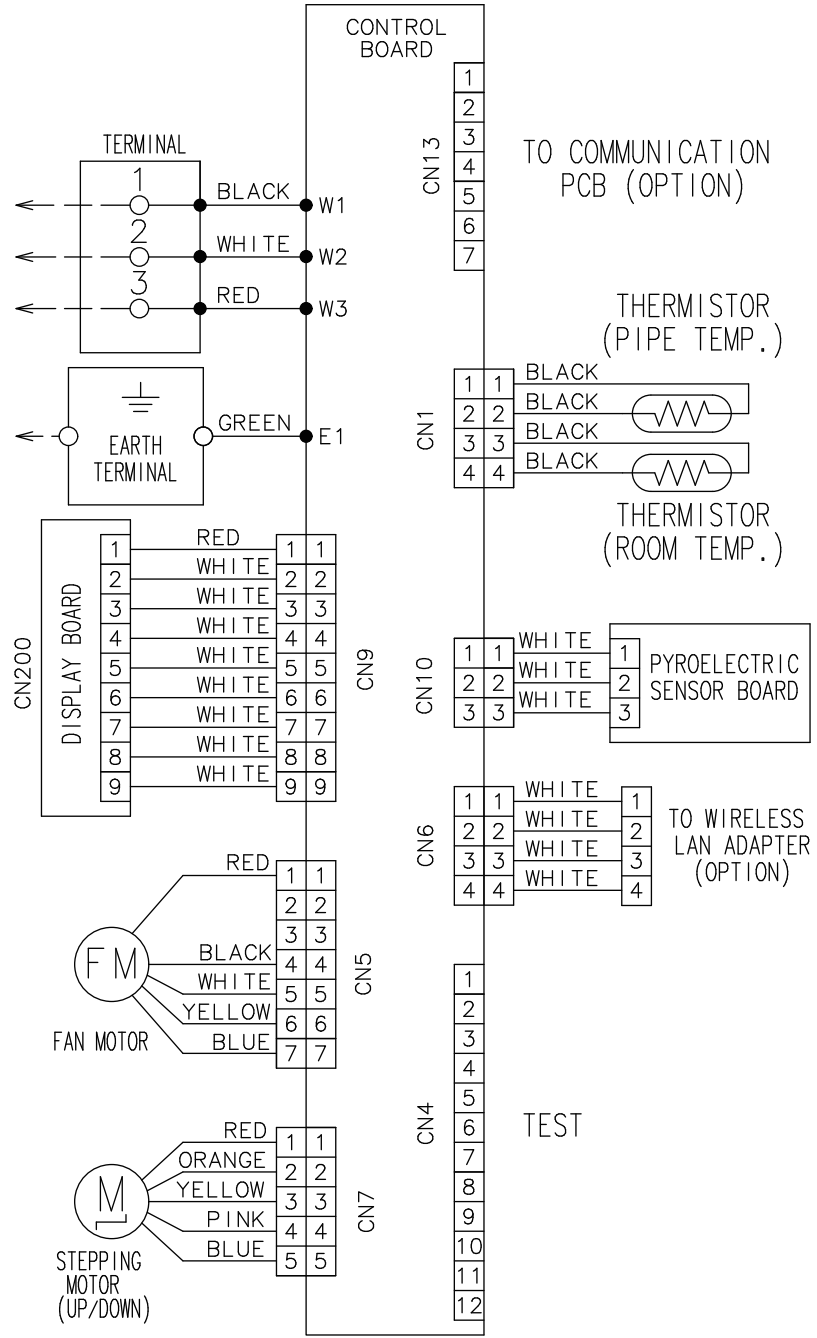

4. Capacity table

Capacity tables show each of following values calculated based on the outdoor temperature and the indoor temperature, under given Airflow Rate (AFR):

For cooling capacity: Total Capacity (TC), Sensible Heat Capacity (SHC), and Input Power (IP)

For heating capacity: Total Capacity (TC) and Input Power (IP)

4-1. Cooling capacity

■ Model: ASYG07KGTA

AFR		m ³ /h																		650					
Outdoor temperature	Indoor temperature																								
	°CDB			18			21			23			25			27			29			32			
	°CWB			12			15			16			18			19			21			23			
	°CDB			TC	SHC	IP	TC	SHC	IP	TC	SHC	IP	TC	SHC	IP	TC	SHC	IP	TC	SHC	IP	TC	SHC	IP	
	kW			kW			kW			kW			kW			kW			kW			kW			
-10	2.29	2.01	0.13	2.48	2.11	0.14	2.72	2.26	0.14	2.85	2.28	0.14	2.95	2.34	0.14	3.17	2.39	0.15	3.37	2.48	0.14				
0	2.25	2.07	0.24	2.43	2.13	0.23	2.57	2.21	0.23	2.68	2.22	0.23	2.79	2.27	0.22	2.96	2.31	0.22	3.18	2.43	0.21				
5	2.29	2.08	0.14	2.47	2.14	0.13	2.61	2.23	0.13	2.73	2.23	0.13	2.84	2.28	0.13	3.01	2.33	0.13	3.23	2.45	0.12				
10	2.25	2.01	0.19	2.43	2.07	0.19	2.57	2.15	0.19	2.68	2.16	0.18	2.79	2.21	0.18	2.96	2.25	0.18	3.18	2.36	0.17				
15	2.21	2.05	0.25	2.38	2.11	0.25	2.51	2.19	0.25	2.63	2.20	0.24	2.73	2.25	0.24	2.90	2.30	0.23	3.11	2.41	0.23				
20	2.20	2.04	0.31	2.38	2.10	0.30	2.51	2.18	0.30	2.62	2.18	0.29	2.72	2.23	0.28	2.89	2.28	0.28	3.10	2.39	0.27				
25	2.08	2.01	0.37	2.25	2.07	0.36	2.37	2.15	0.36	2.48	2.16	0.35	2.58	2.21	0.34	2.73	2.25	0.34	2.93	2.36	0.33				
30	2.00	1.97	0.43	2.16	2.03	0.41	2.28	2.11	0.41	2.39	2.12	0.40	2.48	2.18	0.40	2.63	2.23	0.39	2.82	2.34	0.38				
35	1.95	1.92	0.48	2.10	1.98	0.47	2.22	2.05	0.47	2.31	2.06	0.46	2.40	2.35	0.45	2.55	2.24	0.44	2.74	2.35	0.43				
40	1.82	1.77	0.54	1.96	1.82	0.52	2.07	1.89	0.53	2.16	1.90	0.51	2.25	2.13	0.50	2.39	2.18	0.50	2.56	2.28	0.48				
46	1.69	1.67	0.57	1.83	1.80	0.56	1.95	1.93	0.57	2.03	2.02	0.57	2.14	2.09	0.56	2.24	2.12	0.55	2.42	2.17	0.54				

■ Model: ASYG09KGTA

AFR		m ³ /h																		700					
Outdoor temperature	Indoor temperature																								
	°CDB			18			21			23			25			27			29			32			
	°CWB			12			15			16			18			19			21			23			
	°CDB			TC	SHC	IP	TC	SHC	IP	TC	SHC	IP	TC	SHC	IP	TC	SHC	IP	TC	SHC	IP	TC	SHC	IP	
	kW			kW			kW			kW			kW			kW			kW			kW			
-10	2.75	2.40	0.18	2.98	2.51	0.19	3.26	2.69	0.20	3.42	2.72	0.20	3.54	2.79	0.20	3.81	2.85	0.21	4.04	2.95	0.20				
0	2.71	2.46	0.33	2.92	2.54	0.32	3.08	2.63	0.32	3.22	2.64	0.31	3.35	2.70	0.31	3.55	2.76	0.31	3.81	2.89	0.30				
5	2.75	2.48	0.19	2.97	2.55	0.18	3.13	2.65	0.19	3.27	2.66	0.18	3.41	2.72	0.18	3.61	2.78	0.17	3.87	2.91	0.17				
10	2.71	2.40	0.27	2.92	2.47	0.26	3.08	2.56	0.26	3.22	2.57	0.26	3.35	2.63	0.25	3.55	2.69	0.25	3.81	2.82	0.24				
15	2.65	2.44	0.35	2.86	2.52	0.34	3.02	2.61	0.34	3.15	2.62	0.33	3.28	2.68	0.33	3.48	2.74	0.32	3.73	2.87	0.32				
20	2.64	2.43	0.42	2.85	2.50	0.41	3.01	2.59	0.41	3.14	2.60	0.40	3.27	2.66	0.40	3.47	2.72	0.39	3.72	2.85	0.38				
25	2.50	2.40	0.51	2.70	2.47	0.50	2.85	2.56	0.50	2.97	2.57	0.49	3.09	2.63	0.48	3.28	2.69	0.47	3.52	2.82	0.46				
30	2.41	2.35	0.59	2.60	2.42	0.58	2.74	2.51	0.58	2.86	2.52	0.56	2.98	2.60	0.55	3.16	2.66	0.54	3.39	2.79	0.53				
35	2.33	2.29	0.67	2.52	2.35	0.65	2.66	2.44	0.65	2.78	2.45	0.64	2.89	2.61	0.63	3.06	2.67	0.62	3.29	2.80	0.60				
40	2.18	2.11	0.75	2.36	2.17	0.73	2.49	2.26	0.73	2.60	2.27	0.71	2.70	2.54	0.70	2.86	2.60	0.69	3.07	2.72	0.67				
46	2.03	2.01	0.79	2.20	2.15	0.79	2.34	2.30	0.79	2.44	2.41	0.79	2.57	2.49	0.78	2.69	2.52	0.76	2.90	2.59	0.75				

■ Model: ASYG12KGTA

AFR		m ³ /h																		700					
Outdoor temperature	Indoor temperature																								
	°CDB			18			21			23			25			27			29			32			
	°CWB			12			15			16			18			19			21			23			
	°CDB			TC	SHC	IP	TC	SHC	IP	TC	SHC	IP	TC	SHC	IP	TC	SHC	IP	TC	SHC	IP	TC	SHC	IP	
	kW			kW			kW			kW			kW			kW			kW			kW			
-10	3.09	2.54	0.32	3.45	2.78	0.38	3.82	2.96	0.44	4.00	3.01	0.45	4.13	3.09	0.40	4.41	3.14	0.45	4.62	3.21	0.44				
0	3.30	2.76	0.52	3.57	2.87	0.54	3.76	2.93	0.51	3.94	3.01	0.52	4.04	3.05	0.53	4.37	3.15	0.52	4.68	3.23	0.54				
5	3.27	2.75	0.29	3.54	2.85	0.30	3.72	2.91	0.29	3.91	2.99	0.29	4.00	3.03	0.30	4.33	3.13	0.29	4.64	3.22	0.30				
10	3.23	2.72	0.38	3.49	2.83	0.40	3.68	2.89	0.37	3.86	2.97	0.38	3.95	3.01	0.39	4.28	3.10	0.38	4.58	3.19	0.39				
15	3.17	2.69	0.46	3.43	2.80	0.48	3.61	2.86	0.46	3.79	2.93	0.47	3.88	2.98	0.47	4.20	3.07	0.47	4.50	3.15	0.48				
20	3.10	2.65	0.54	3.35	2.76	0.57	3.53	2.81	0.54	3.71	2.89	0.55	3.79	2.93	0.56	4.11	3.02	0.55	4.40	3.11	0.56				
25	3.01	2.61	0.62	3.26	2.71	0.65	3.43	2.76	0.61	3.60	2.84	0.62	3.69	2.88	0.63	3.99	2.97	0.62	4.27	3.05	0.64				
30	2.91	2.55	0.69	3.15	2.65	0.72	3.31	2.70	0.68	3.48	2.78	0.69	3.56	2.82	0.71	3.85	2.90	0.69	4.13	2.98	0.72				
35	2.79	2.48	0.76	3.02	2.58	0.79	3.18	2.63	0.75	3.34	2.71	0.76	3.42	2.75	0.77	3.70	2.83	0.76	3.96	2.91	0.79				
40	2.66	2.41	0.82	2.88	2.51	0.86	3.03	2.56	0.81	3.18	2.63	0.82	3.25	2.66	0.84	3.52	2.75	0.82	3.77	2.82	0.85				
46	2.45	2.40	0.91	2.62	2.51	0.88	2.77	2.60	0.91	2.85	2.62	0.88	2.90	2.59	0.90	3.10	2.72	0.92	3.32	2.75	0.92				

Model: ASYG14KGTA

AFR	m ³ /h	770
-----	-------------------	-----

		Indoor temperature																				
		18			21			23			25			27			29			32		
		°CWB			15			16			18			19			21			23		
Outdoor temperature	°CDB	TC	SHC	IP	TC	SHC	IP	TC	SHC	IP	TC	SHC	IP	TC	SHC	IP	TC	SHC	IP	TC	SHC	IP
	-10	3.35	2.71	0.35	3.74	2.97	0.42	4.14	3.16	0.48	4.34	3.22	0.49	4.48	3.30	0.44	4.78	3.35	0.49	5.01	3.43	0.49
	0	3.57	2.95	0.57	3.87	3.06	0.60	4.07	3.13	0.56	4.27	3.21	0.57	4.37	3.26	0.58	4.73	3.36	0.57	5.07	3.45	0.59
	5	3.54	2.93	0.32	3.84	3.05	0.33	4.04	3.11	0.31	4.24	3.20	0.32	4.34	3.24	0.32	4.70	3.34	0.32	5.03	3.43	0.33
	10	3.50	2.91	0.42	3.79	3.02	0.43	3.98	3.09	0.41	4.18	3.17	0.42	4.28	3.21	0.42	4.63	3.31	0.42	4.96	3.41	0.43
	15	3.44	2.88	0.51	3.72	2.99	0.53	3.91	3.05	0.50	4.11	3.13	0.51	4.21	3.18	0.52	4.55	3.28	0.51	4.88	3.37	0.53
	20	3.36	2.83	0.60	3.63	2.94	0.62	3.82	3.01	0.59	4.02	3.09	0.60	4.11	3.13	0.61	4.45	3.23	0.60	4.77	3.32	0.62
	25	3.26	2.78	0.68	3.53	2.89	0.71	3.72	2.95	0.67	3.90	3.03	0.68	3.99	3.07	0.69	4.32	3.17	0.68	4.63	3.26	0.71
	30	3.15	2.72	0.76	3.41	2.83	0.79	3.59	2.89	0.75	3.77	2.97	0.76	3.86	3.01	0.77	4.18	3.10	0.76	4.47	3.19	0.79
	35	3.02	2.65	0.83	3.27	2.76	0.87	3.44	2.81	0.82	3.62	2.89	0.84	3.70	2.93	0.85	4.01	3.02	0.84	4.29	3.11	0.86
40	2.88	2.58	0.90	3.12	2.68	0.94	3.28	2.73	0.89	3.45	2.81	0.90	3.53	2.85	0.92	3.82	2.93	0.91	4.09	3.01	0.94	
46	2.65	2.56	1.00	2.84	2.68	0.96	3.01	2.78	1.00	3.08	2.80	0.97	3.15	2.76	0.98	3.36	2.90	1.01	3.59	2.94	1.01	

4-2. Heating capacity

NOTE: Values mentioned in the table are calculated based on the maximum capacity.

■ Model: ASYG07KGTA

AFR		m ³ /h		720									
		Indoor temperature											
		16		18		20		22		24			
		TC	IP	TC	IP	TC	IP	TC	IP	TC	IP		
Outdoor temperature	°CDB	°CWB	kW		kW		kW		kW		kW		
	-15	-16	3.08	1.30	3.11	1.35	3.09	1.38	3.06	1.42	3.04	1.43	
	-10	-11	3.62	1.39	3.66	1.44	3.63	1.46	3.60	1.51	3.58	1.52	
	-5	-7	4.10	1.44	4.13	1.49	4.10	1.52	4.06	1.56	4.04	1.57	
	0	-2	4.50	1.48	4.54	1.53	4.43	1.53	4.36	1.56	4.35	1.59	
	5	3	4.86	1.45	4.94	1.51	4.82	1.51	4.74	1.55	4.73	1.57	
	7	6	5.24	1.48	5.33	1.58	5.20	1.58	5.12	1.62	5.11	1.64	
	10	8	5.39	1.51	5.49	1.61	5.28	1.59	5.27	1.65	5.26	1.67	
	15	10	5.29	1.31	5.38	1.40	5.16	1.40	5.17	1.43	5.16	1.45	
	20	15	5.54	1.25	5.54	1.23	5.38	1.24	5.26	1.23	5.11	1.25	
24	18	5.69	1.18	5.69	1.17	5.53	1.17	5.40	1.16	5.26	1.18		

■ Model: ASYG09KGTA

AFR		m ³ /h		750									
		Indoor temperature											
		16		18		20		22		24			
		TC	IP	TC	IP	TC	IP	TC	IP	TC	IP		
Outdoor temperature	°CDB	°CWB	kW		kW		kW		kW		kW		
	-15	-16	3.20	1.42	3.23	1.47	3.21	1.50	3.18	1.54	3.16	1.55	
	-10	-11	3.76	1.51	3.80	1.57	3.77	1.59	3.74	1.64	3.72	1.65	
	-5	-7	4.26	1.56	4.29	1.62	4.26	1.65	4.22	1.70	4.19	1.71	
	0	-2	4.67	1.61	4.72	1.67	4.61	1.66	4.53	1.70	4.52	1.73	
	5	3	5.04	1.58	5.13	1.65	5.01	1.65	4.93	1.68	4.92	1.71	
	7	6	5.44	1.61	5.53	1.72	5.40	1.72	5.31	1.76	5.30	1.79	
	10	8	5.60	1.64	5.70	1.76	5.48	1.73	5.47	1.79	5.46	1.82	
	15	10	5.49	1.42	5.59	1.52	5.36	1.52	5.37	1.55	5.35	1.58	
	20	15	5.75	1.36	5.75	1.34	5.58	1.35	5.46	1.34	5.31	1.36	
24	18	5.91	1.29	5.91	1.27	5.74	1.28	5.61	1.27	5.46	1.29		

■ Model: ASYG12KGTA

AFR		m ³ /h		770									
		Indoor temperature											
		16		18		20		22		24			
		TC	IP	TC	IP	TC	IP	TC	IP	TC	IP		
Outdoor temperature	°CDB	°CWB	kW		kW		kW		kW		kW		
	-15	-16	3.40	1.39	3.39	1.36	3.36	1.36	3.34	1.37	3.30	1.40	
	-10	-11	4.02	1.41	3.93	1.43	3.83	1.46	3.72	1.48	3.60	1.52	
	-5	-7	4.60	1.51	4.50	1.54	4.39	1.57	4.26	1.60	4.12	1.63	
	0	-2	5.29	1.63	5.17	1.66	5.04	1.69	4.89	1.72	4.73	1.76	
	5	3	6.06	1.77	5.93	1.79	5.78	1.83	5.61	1.87	5.43	1.91	
	7	6	6.40	1.82	6.26	1.85	6.10	1.89	5.92	1.93	5.73	1.97	
	10	8	6.94	1.92	6.78	1.94	6.61	1.98	6.42	2.02	6.21	2.07	
	15	10	6.33	1.58	6.19	1.60	6.03	1.63	5.86	1.66	5.67	1.70	
	20	15	6.61	1.38	6.46	1.41	6.29	1.43	6.11	1.46	5.91	1.50	
24	18	6.89	1.32	6.75	1.40	6.50	1.37	6.14	1.36	5.66	1.39		

■ Model: ASYG14KGTA

AFR		m ³ /h		800									
		Indoor temperature											
		16		18		20		22		24			
		TC	IP	TC	IP	TC	IP	TC	IP	TC	IP		
Outdoor temperature	°CDB	°CWB	kW		kW		kW		kW		kW		
	-15	-16	3.57	1.51	3.56	1.49	3.52	1.48	3.51	1.50	3.46	1.53	
	-10	-11	4.22	1.53	4.12	1.56	4.02	1.59	3.90	1.62	3.77	1.66	
	-5	-7	4.83	1.65	4.72	1.67	4.60	1.71	4.47	1.74	4.33	1.78	
	0	-2	5.55	1.78	5.42	1.81	5.29	1.84	5.13	1.88	4.97	1.92	
	5	3	6.36	1.93	6.22	1.96	6.06	1.99	5.89	2.03	5.70	2.08	
	7	6	6.72	1.99	6.57	2.02	6.40	2.06	6.21	2.10	6.01	2.15	
	10	8	7.28	2.09	7.11	2.12	6.93	2.16	6.73	2.20	6.52	2.26	
	15	10	6.64	1.72	6.49	1.74	6.33	1.78	6.15	1.81	5.95	1.86	
	20	15	6.93	1.51	6.77	1.53	6.60	1.56	6.41	1.59	6.20	1.63	
24	18	7.22	1.44	7.08	1.53	6.82	1.50	6.44	1.48	5.94	1.52		

5. Fan performance

5-1. Air velocity distributions

■ Models: ASYG07KGTA and ASYG09KGTA

Measuring conditions	Fan speed	Operation mode
	HIGH	FAN

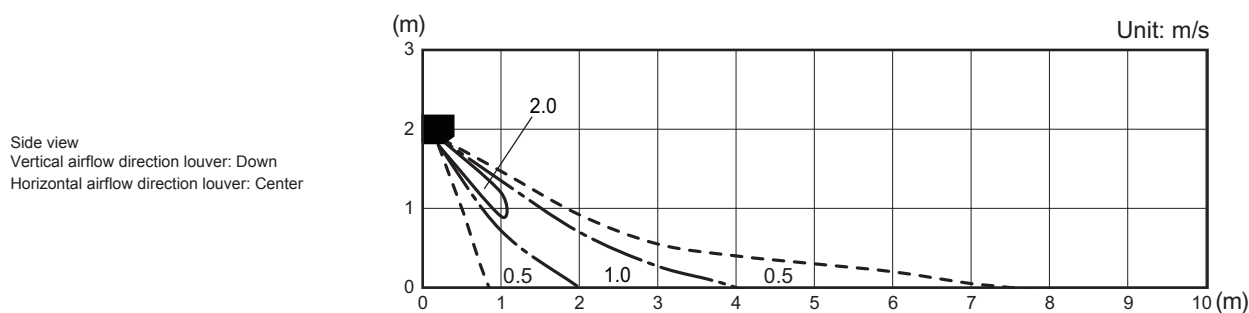
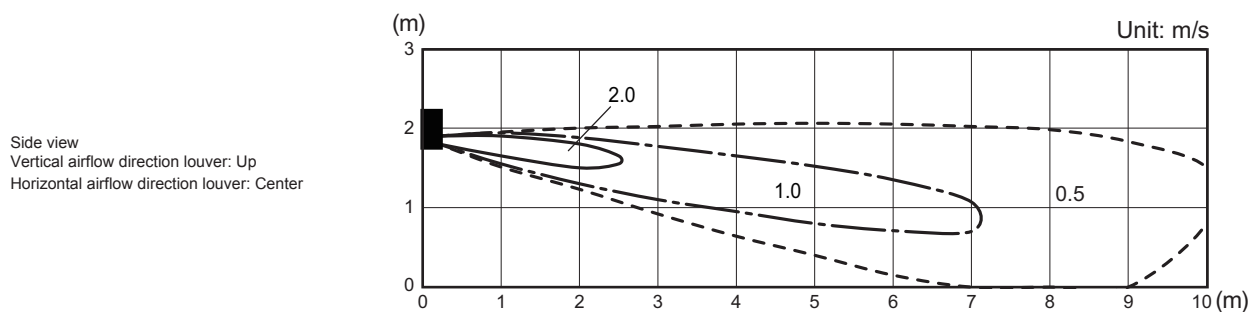
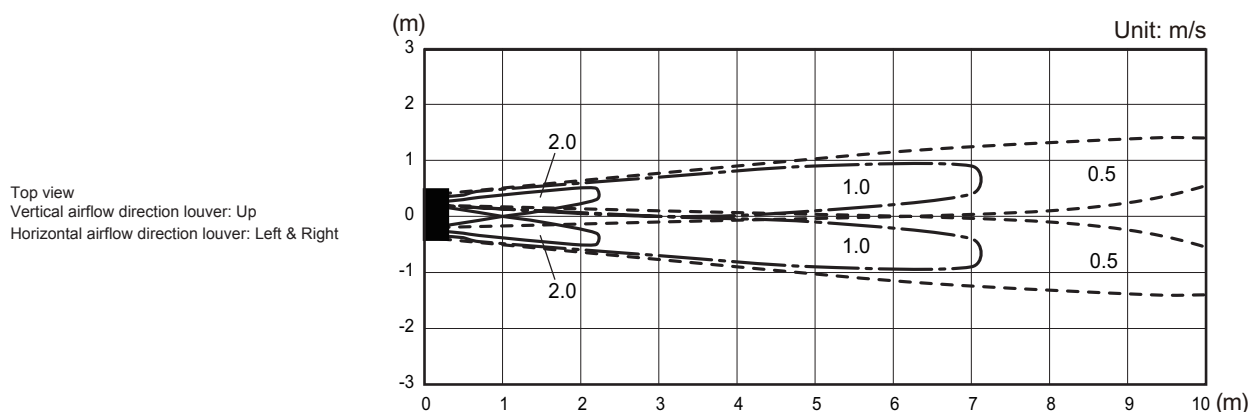
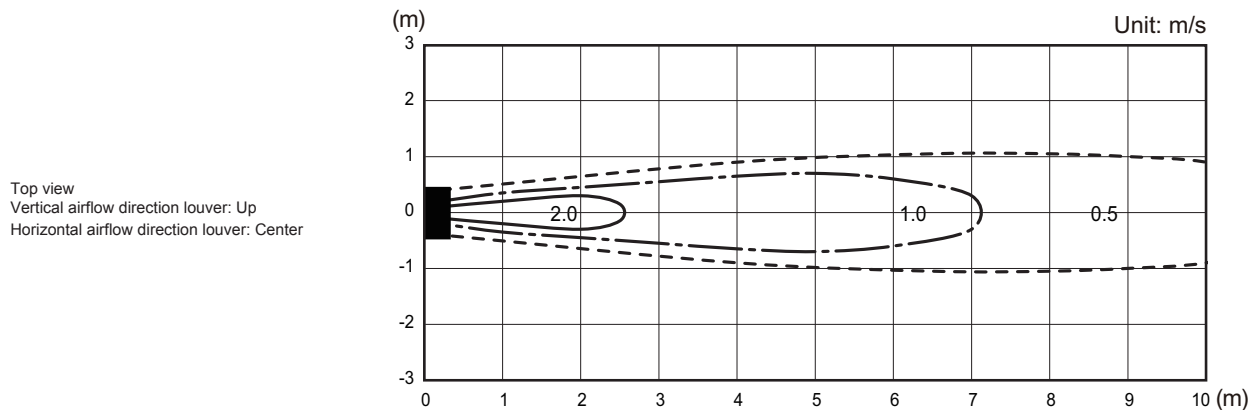

Models: ASYG12KGTA and ASYG14KGTA

Measuring conditions	Fan speed	Operation mode
	HIGH	FAN

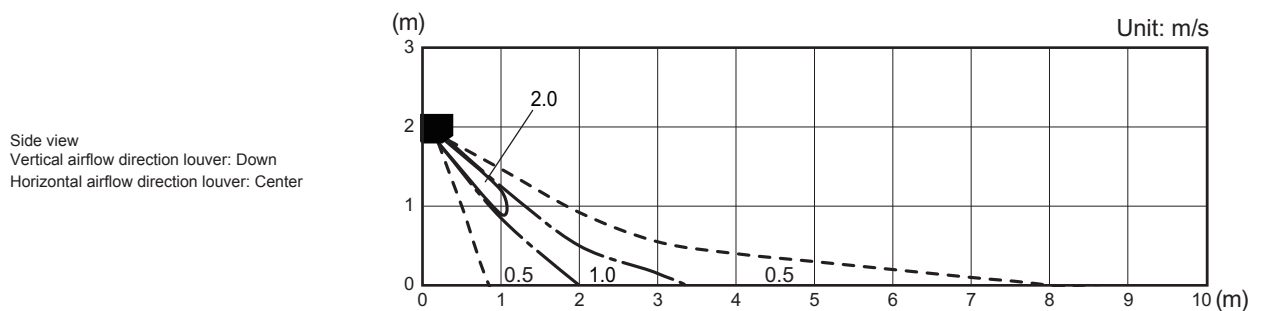
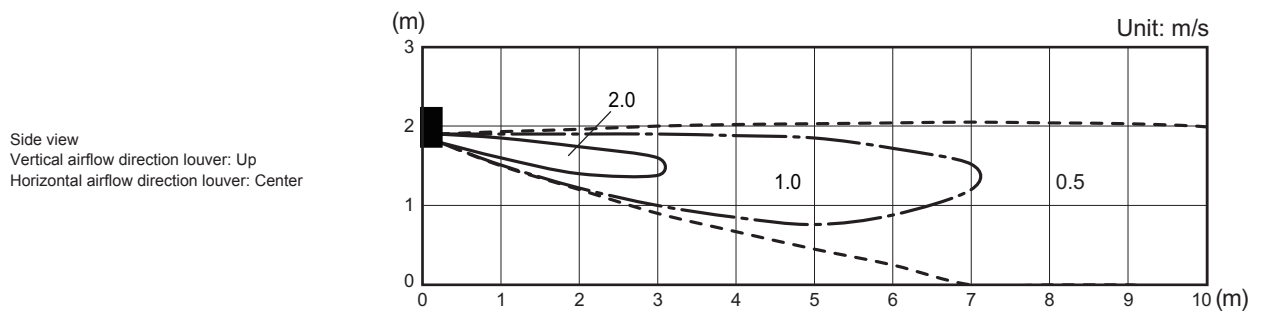
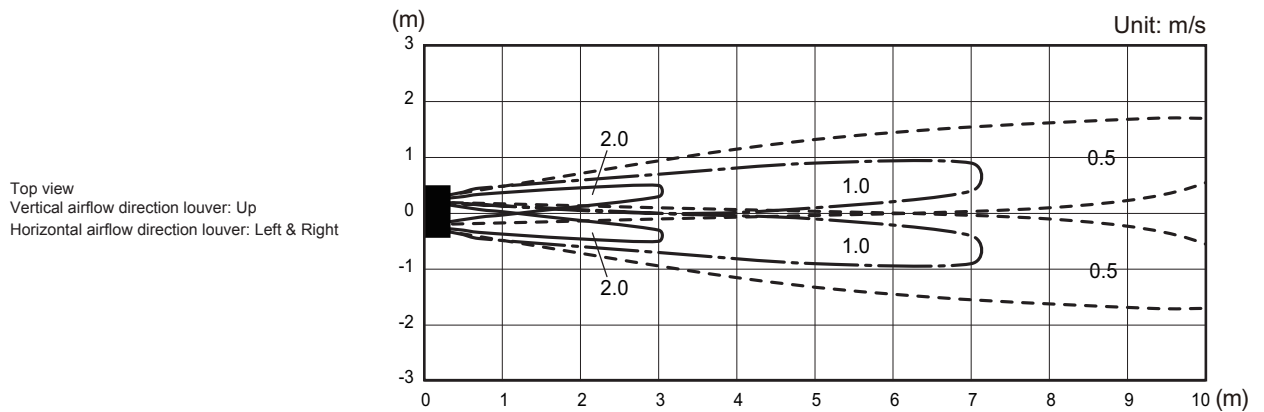
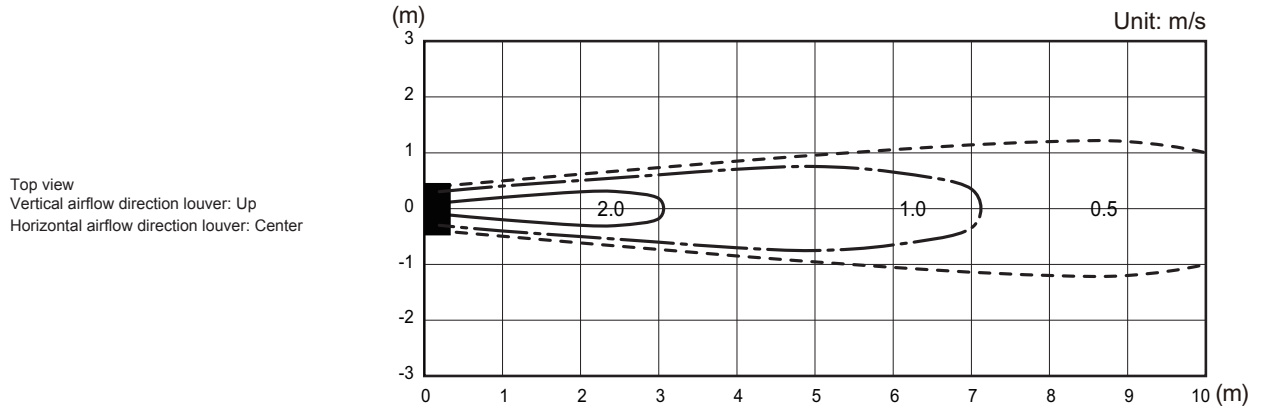

5-2. Airflow

■ Model: ASYG07KGTA

● Cooling

Fan speed	Airflow	
HIGH	m ³ /h	650
	l/s	181
	CFM	383
MED	m ³ /h	540
	l/s	150
	CFM	318
LOW	m ³ /h	430
	l/s	119
	CFM	253
QUIET	m ³ /h	270
	l/s	75
	CFM	159

● Heating

Fan speed	Airflow	
HIGH	m ³ /h	720
	l/s	200
	CFM	424
MED	m ³ /h	580
	l/s	161
	CFM	341
LOW	m ³ /h	460
	l/s	128
	CFM	271
QUIET	m ³ /h	330
	l/s	92
	CFM	194

■ Model: ASYG09KGTA

● Cooling

Fan speed	Airflow	
HIGH	m ³ /h	700
	l/s	194
	CFM	412
MED	m ³ /h	560
	l/s	156
	CFM	330
LOW	m ³ /h	430
	l/s	119
	CFM	253
QUIET	m ³ /h	270
	l/s	75
	CFM	159

● Heating

Fan speed	Airflow	
HIGH	m ³ /h	750
	l/s	208
	CFM	441
MED	m ³ /h	610
	l/s	169
	CFM	359
LOW	m ³ /h	470
	l/s	131
	CFM	277
QUIET	m ³ /h	330
	l/s	92
	CFM	194

■ Model: ASYG12KGTA

● Cooling

Fan speed	Airflow	
HIGH	m ³ /h	700
	l/s	194
	CFM	412
MED	m ³ /h	560
	l/s	156
	CFM	330
LOW	m ³ /h	430
	l/s	119
	CFM	253
QUIET	m ³ /h	250
	l/s	69
	CFM	147

● Heating

Fan speed	Airflow	
HIGH	m ³ /h	770
	l/s	214
	CFM	453
MED	m ³ /h	640
	l/s	178
	CFM	377
LOW	m ³ /h	520
	l/s	144
	CFM	306
QUIET	m ³ /h	310
	l/s	86
	CFM	182

■ Model: ASYG14KGTA

● Cooling

Fan speed	Airflow	
HIGH	m ³ /h	770
	l/s	214
	CFM	453
MED	m ³ /h	600
	l/s	167
	CFM	353
LOW	m ³ /h	450
	l/s	125
	CFM	265
QUIET	m ³ /h	280
	l/s	78
	CFM	165

● Heating

Fan speed	Airflow	
HIGH	m ³ /h	800
	l/s	222
	CFM	471
MED	m ³ /h	660
	l/s	183
	CFM	388
LOW	m ³ /h	520
	l/s	144
	CFM	306
QUIET	m ³ /h	340
	l/s	94
	CFM	200

6. Operation noise (sound pressure)

6-1. Noise level curve

■ Model: ASYG07KGTA

● Cooling

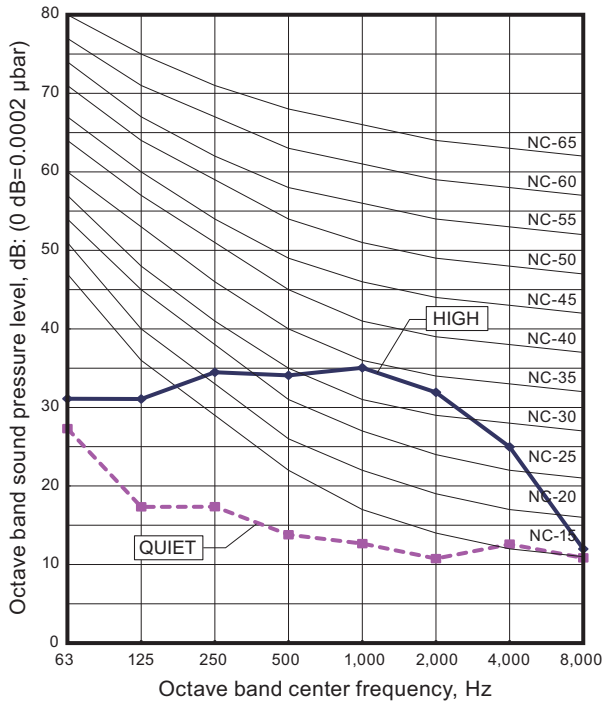

● Heating

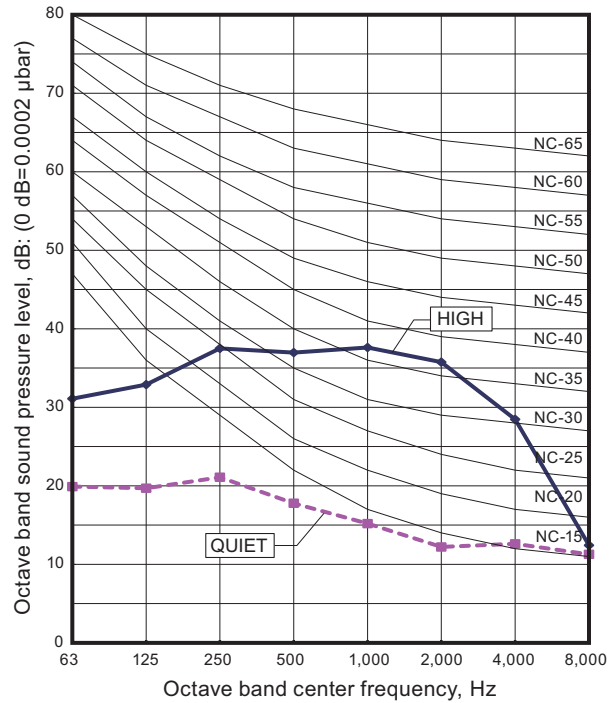

■ Model: ASYG09KGTA

● Cooling

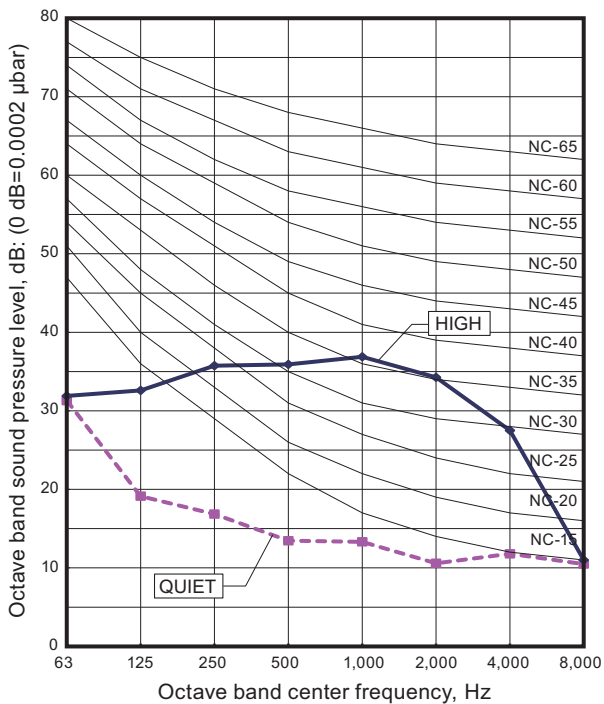

● Heating

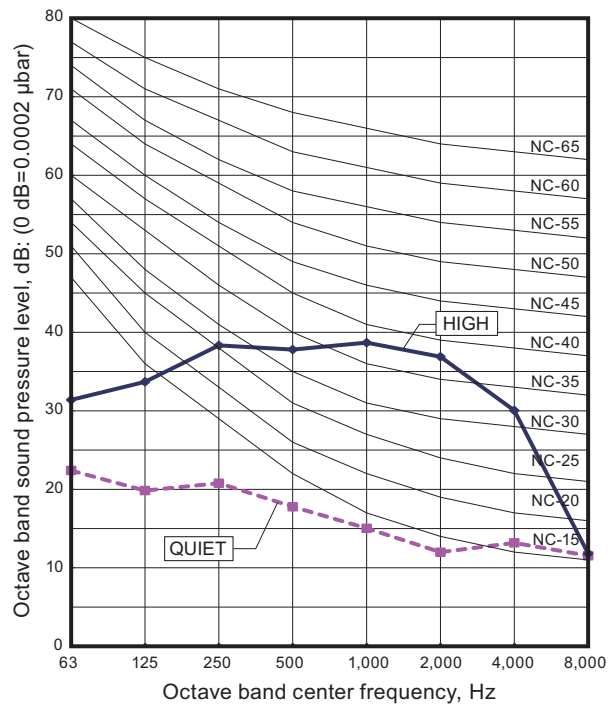

Model: ASYG12KGTA

Cooling

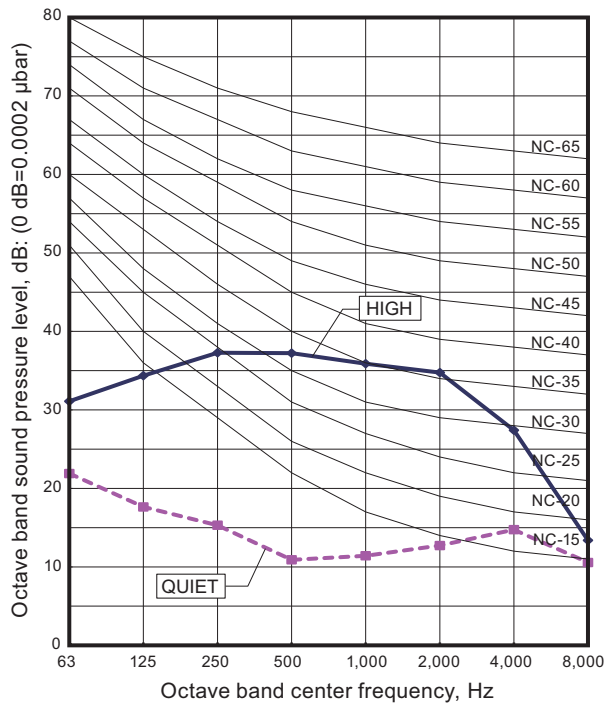

Heating

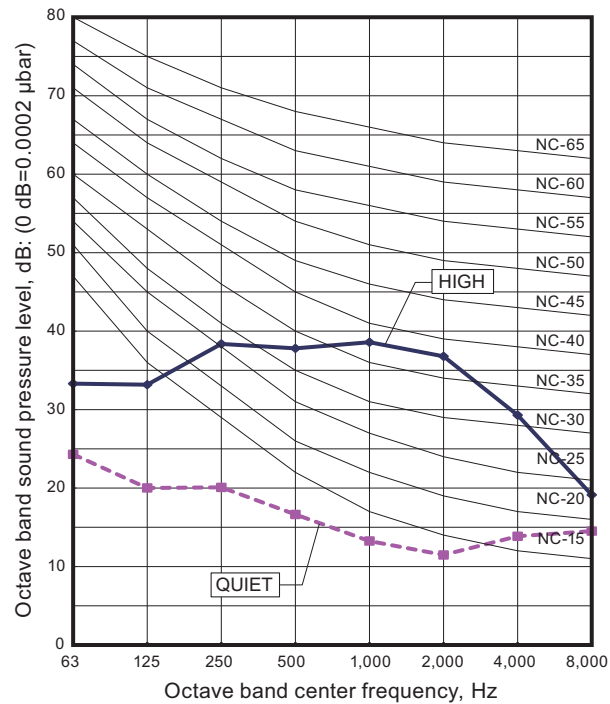

Model: ASYG14KGTA

Cooling

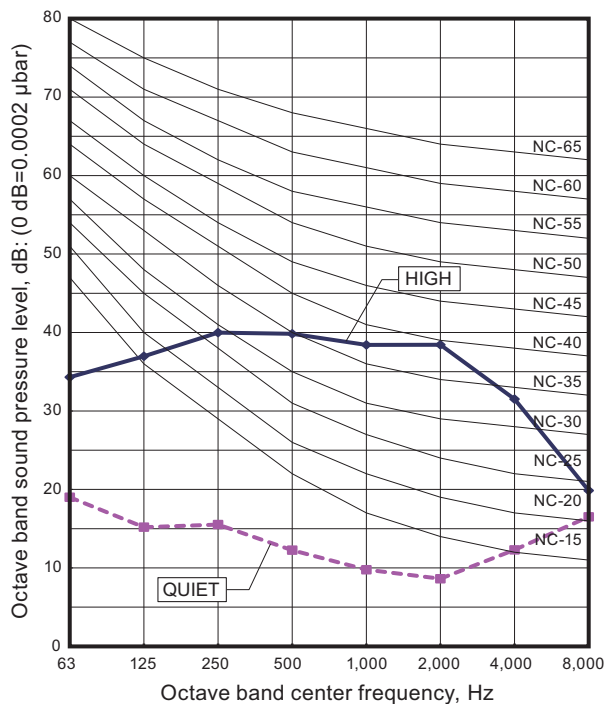

Heating

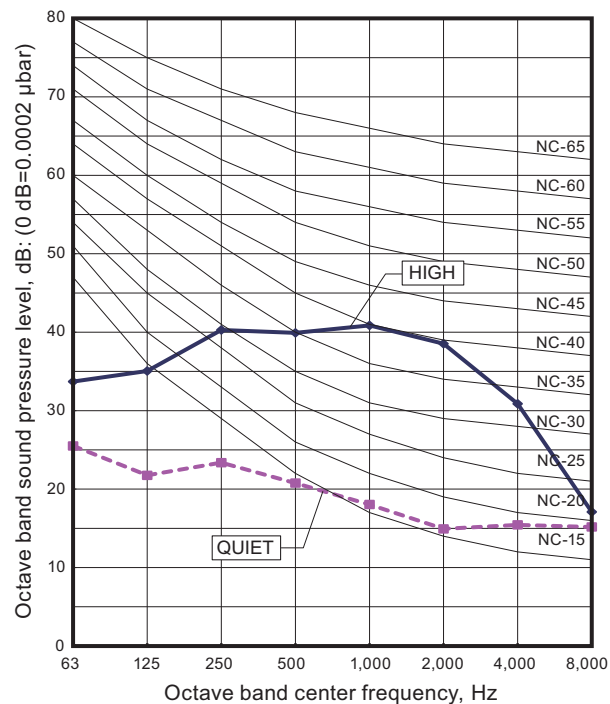

6-2. Sound level check point

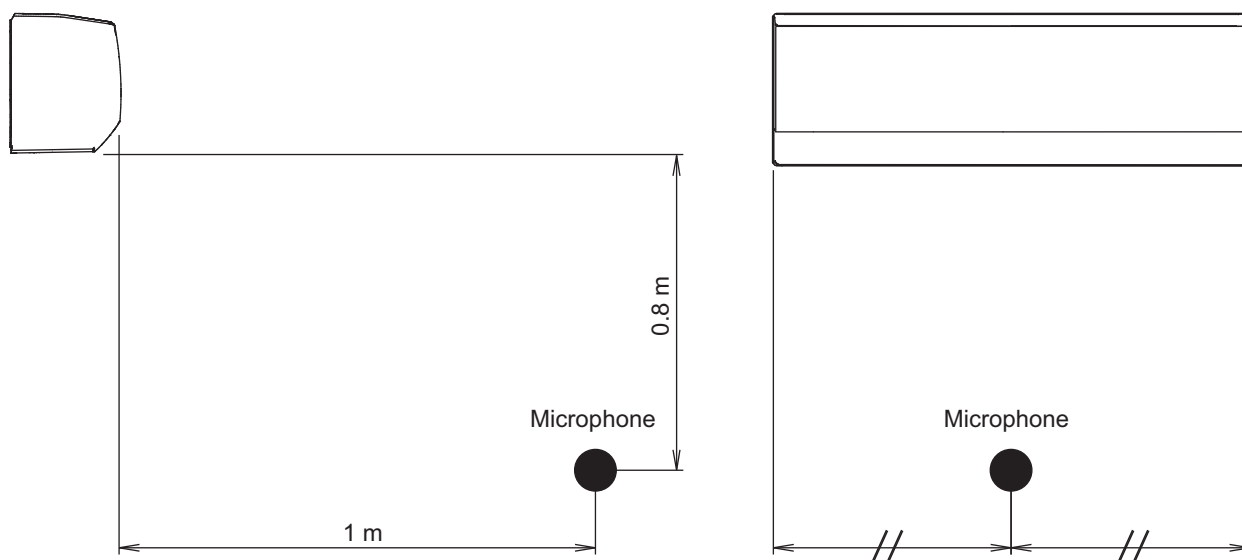

NOTE: Detailed shape of the actual indoor unit might be slightly different from the one illustrated above.

7. Safety devices

Type of protection	Protection form		Model	
			ASYG07KGTA	ASYG09KGTA
Circuit protection	Current fuse (PCB*)		250 V, 3.15 A	
Fan motor protection	Thermistor protection	Activate	More than 85 °C Fan motor speed down	
		Reset	85 °C or less Fan motor speed recover	

Type of protection	Protection form		Model	
			ASYG12KGTA	ASYG14KGTA
Circuit protection	Current fuse (PCB*)		250 V, 3.15 A	
Fan motor protection	Power IC thermal shutdown protection	Activate	125±25 °C Fan motor stop	
		Reset	110 ⁺²⁵ ₋₂₀ °C Fan motor restart	

*PCB: Printed Circuit Board

8. External input and output

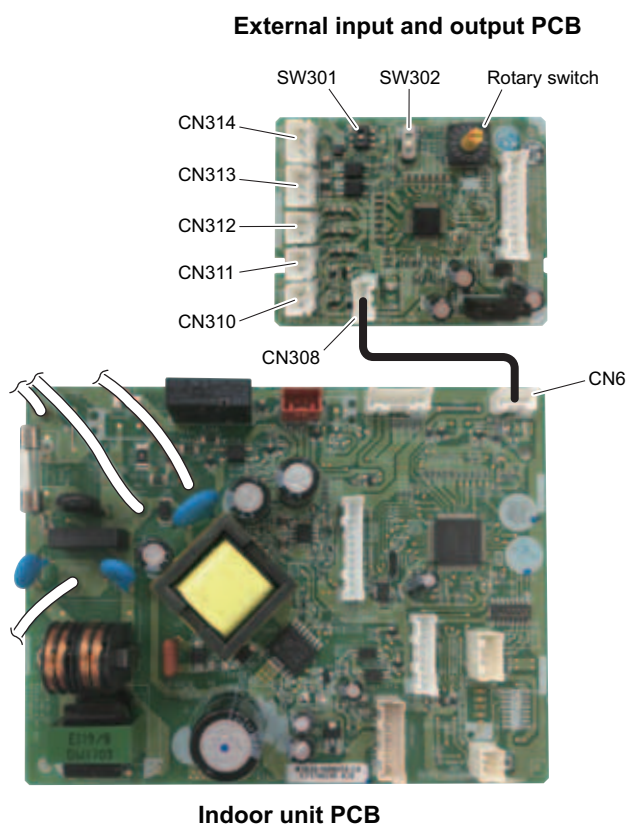

PCB	External input	External output	Connector	Input select	Input signal
External input and output (UTY-XCSXZ2)	Operation/Stop	-	CN313/ CN314	Dry contact/ Apply voltage	Edge/Pulse
	Forced stop				Edge
	Forced thermostat off				CN313
	-	Operation status	CN310	-	-
		Error status	CN311		
		Indoor unit fan operation status	CN312		

8-1. External input

With using external input function, some functions on this product can be controlled from an external device.

- "Operation/Stop" mode or "Forced stop" mode can be selected with function setting of indoor unit.
- A twisted pair cable should be used. Maximum length of cable is 150 m.
- The wire connection should be separate from the power cable line.

External input and output PCB

The indoor unit Operation/Stop can be set by using the input connector on the PCB.

Input select:

Use either one of these types of connectors according to the application. (Both types of connectors cannot be used simultaneously.)

– Dry contact

In case of internal power supply, set the slide switch of SW301 to "NON VOL" side.

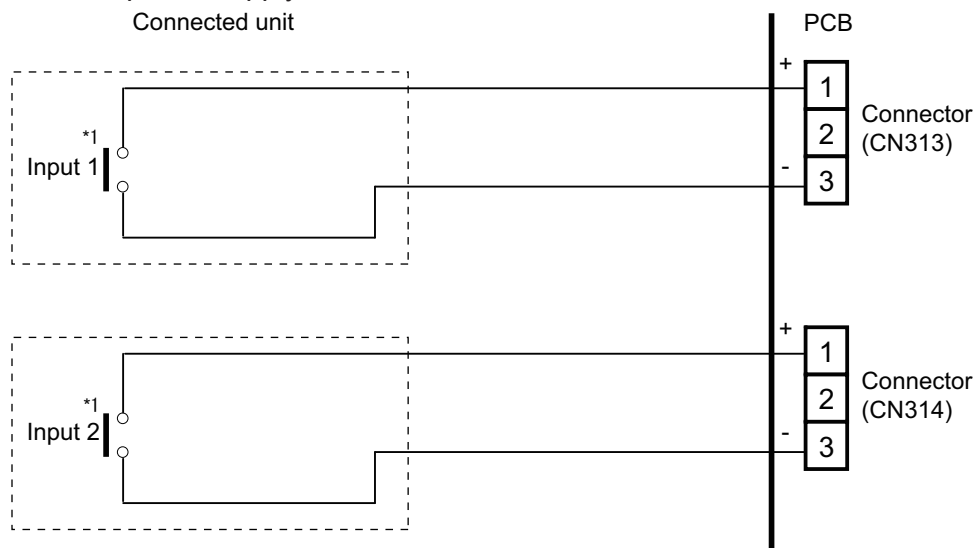

*1: The switches can be used on the following condition: DC 12 V to 24 V, 1 mA to 15 mA.

– Apply voltage

In case of external power supply, set the slide switch of SW301 to "VOL" side.

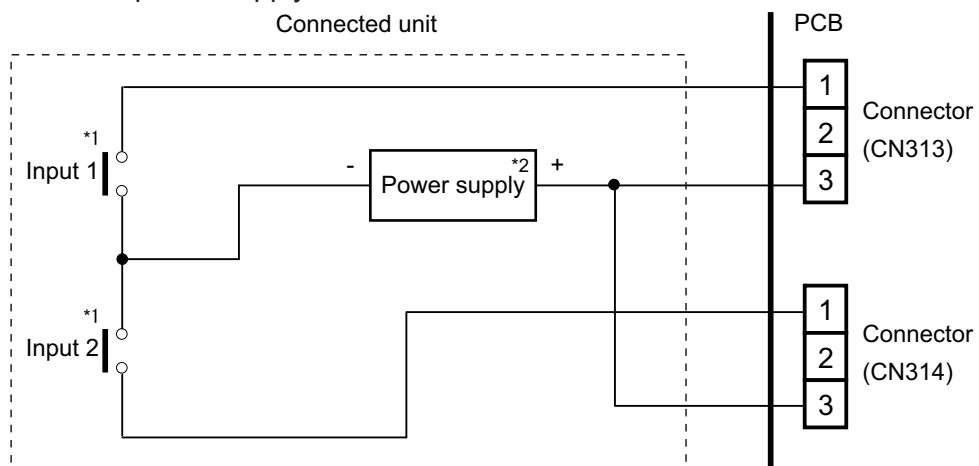

*1: The switches can be used on the following condition: DC 12 V to 24 V, 1 mA to 15 mA.

*2: Make the power supply DC 12 to 24 V, 10 mA or more.

8-2. External output

Use an external output cable with appropriate external dimension, depending on the number of cables to be installed.

External input and output PCB

- A twisted pair cable (22AWG) should be used. Maximum length of cable is 25 m.
- Output voltage: High DC 12 V±2 V, Low 0 V.
- Permissible current: 50 mA
- For details, refer to "[Combination of external input and output](#)" on page 23.

- **When indicator or other components are connected directly:**

Example: Function setting 60 is set to "00".

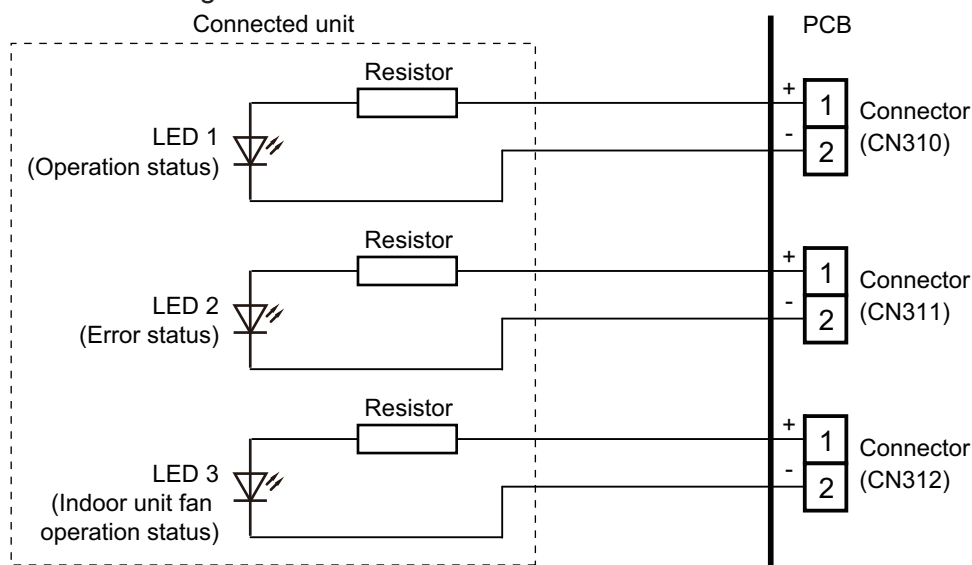

- **When connecting with a device equipped with a power supply:**

Example: Function setting 60 is set to "00".

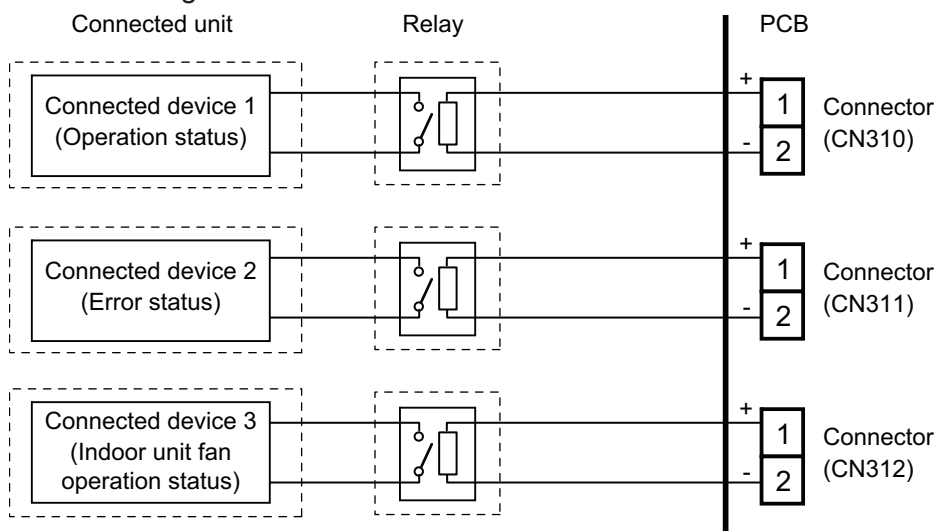

8-3. Combination of external input and output

By combining the function setting of the indoor unit and rotary switch setting of the External input and output PCB, you can select various combinations of functions.

Combination examples of external input and output are as follows:

Mode	Function setting	External input and output PCB (Rotary SW)	External input		
			External input and output PCB		
			CN313	CN314	Signal type
0-1	60-00	1	Operation/Stop	Not available	Edge
			Operation	Stop	Pulse
0-2	60-00	2	Forced Thermostat OFF	Not available	Edge
1—8	60-01 to 60-08	3 - 9, A	(Setting prohibited)		
9	60-09	B	Forced Thermostat OFF	Not available	Edge
10	60-10	C	Forced Thermostat OFF	Not available	Edge
11	60-11	D	Forced Thermostat OFF	Not available	Edge

Mode	Function setting	External input and output PCB (Rotary SW)	External output		
			External input and output PCB		
			CN310	CN311	CN312
0-1	60-00	1	Operation/Stop	Error status	Indoor unit fan operation status
0-2	60-00	2	Error status	Indoor unit fan operation status	Not available
1—8	60-01 to 60-08	3 - 9, A	(Setting prohibited)		
9	60-09	B	Operation/Stop	Indoor unit fan operation status	Not available
10	60-10	C	Operation/Stop	Error status	Not available
11	60-11	D	Operation/Stop	Indoor unit fan operation status	Error status

NOTE: Input of Operation/Stop depends on the setting of function setting 46.

00: Operation/Stop mode 1 (R.C. enabled)

01: (Setting prohibited)

02: Forced stop

03: Operation/Stop mode 2 (R.C. disabled)

■ Input signal type

External input and output PCB:

The input signal type can be selected.

Signal type (edge or pulse) can be switched by the DIP switch SW302 on the External input and output PCB.

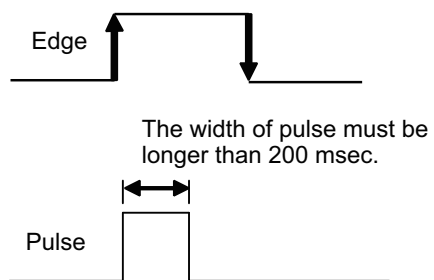

8-4. Details of function

■ Control input function

- When function setting is "Operation/Stop" mode 1
 - In the case of "Edge" input:

Function setting /	Rotary SW on External input and output PCB	External input		Input signal	Command
		External input and output PCB	CN313		
46-00	60-00 / 1			Off → On	Operation
				On → Off	Stop

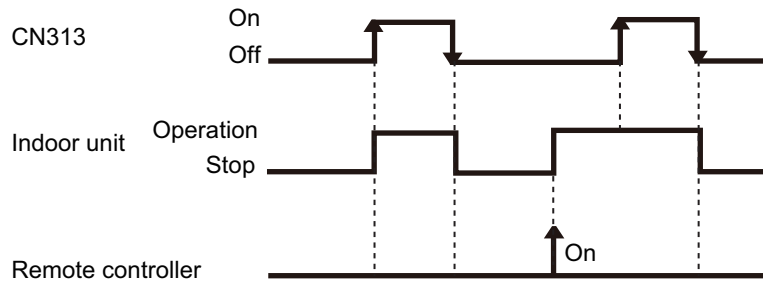

- In the case of "Pulse" input:

Function setting /	Rotary SW on External input and output PCB	External input		Input signal	Command
		External input and output PCB	CN313		
46-00	60-00 / 1		CN313	Pulse	Operation
			CN314	Pulse	Stop

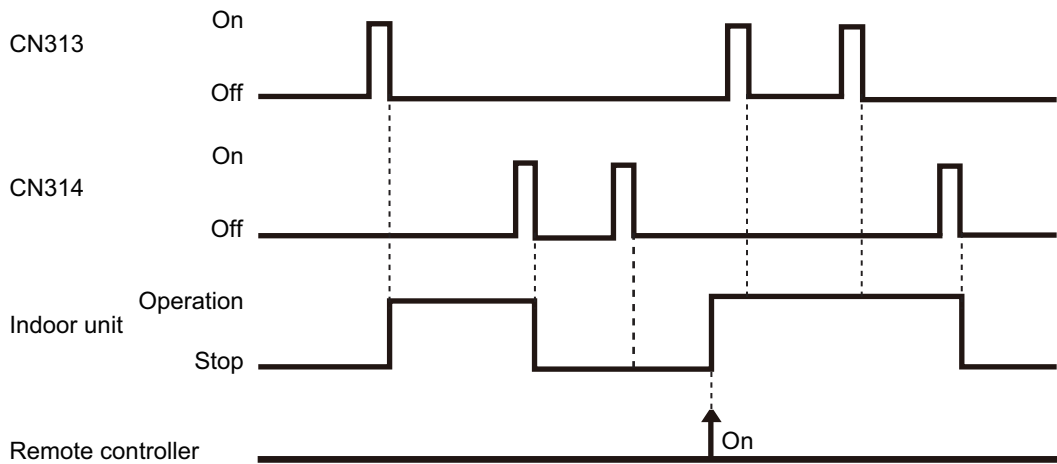

NOTES:

- The last command has priority.
- The indoor units within the same remote controller group operates in the same mode.

• When function setting is "Forced stop" mode

– In the case of "Edge" input:

Function setting /	Rotary SW on External input and output PCB	External input		Input signal	Command
		External input and output PCB	CN313		
46-02	60-00 / 1	External input and output PCB	CN313	Off → On	Forced stop
				On → Off	Normal

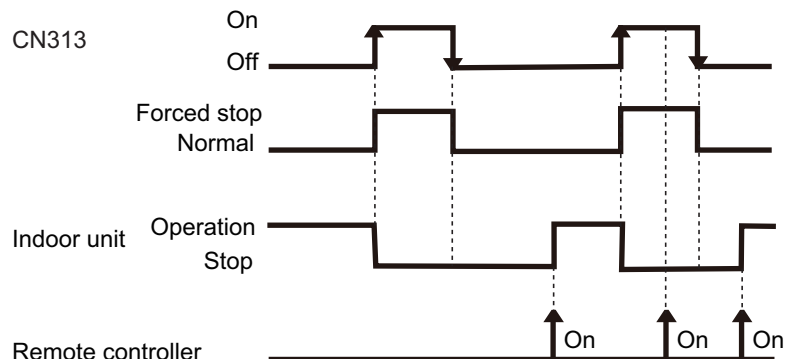

– In the case of "Pulse" input:

Function setting /	Rotary SW on External input and output PCB	External input		Input signal	Command
		External input and output PCB	CN313		
46-02	60-00 / 1	External input and output PCB	CN313	Pulse	Forced stop
			CN314	Pulse	Normal

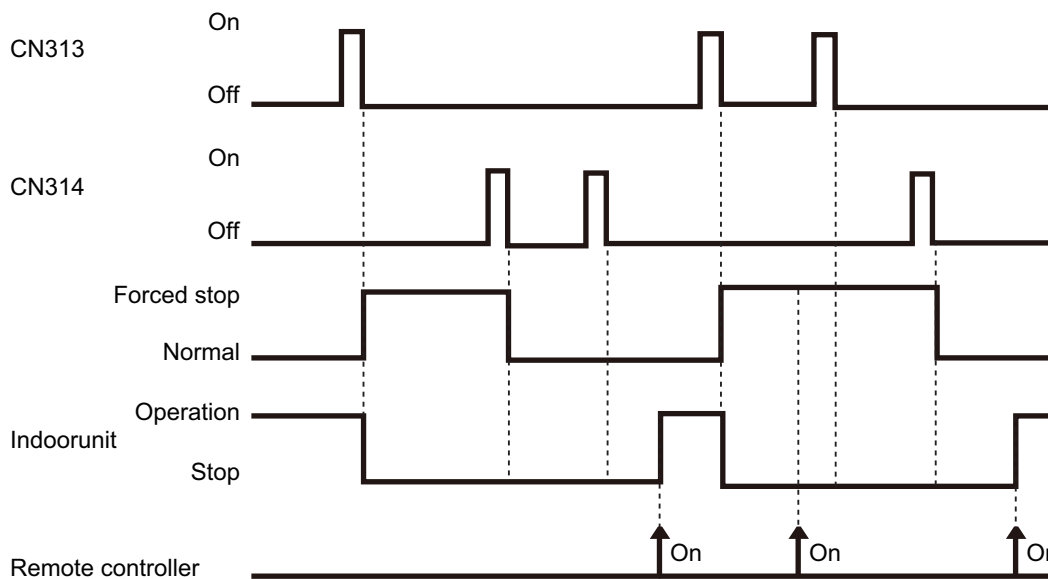

NOTES:

- When the forced stop is triggered, indoor unit stops and Operation/Stop operation by the remote controller is restricted.
- When forced stop function is used with forming a remote controller group, connect the same equipment to each indoor unit within the group.

• When function setting is "Operation/Stop" mode 2

– In the case of "Edge" input:

Function setting /	Rotary SW on External input and output PCB	External input		Input signal	Command
46-03	60-00 / 1	External input and output PCB	CN313	Off → On	Operation
				On → Off	Stop (R.C. disabled)

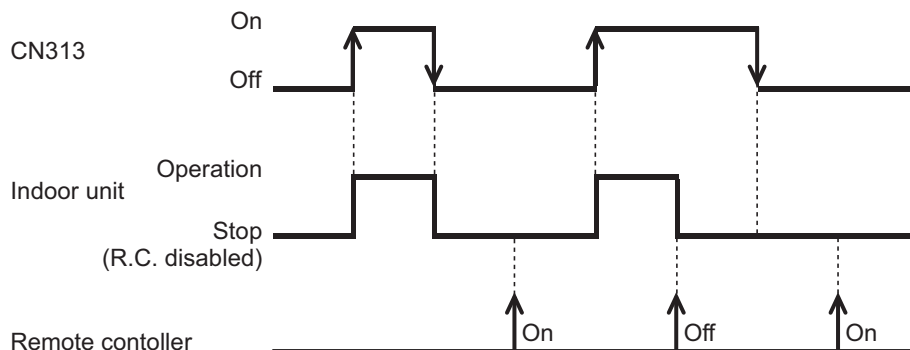

– In the case of "Pulse" input:

Function setting /	Rotary SW on External input and output PCB	External input		Input signal	Command
46-03	60-00 / 1	External input and output PCB	CN313	Pulse	Operation
			CN314	Pulse	Stop (R.C. disabled)

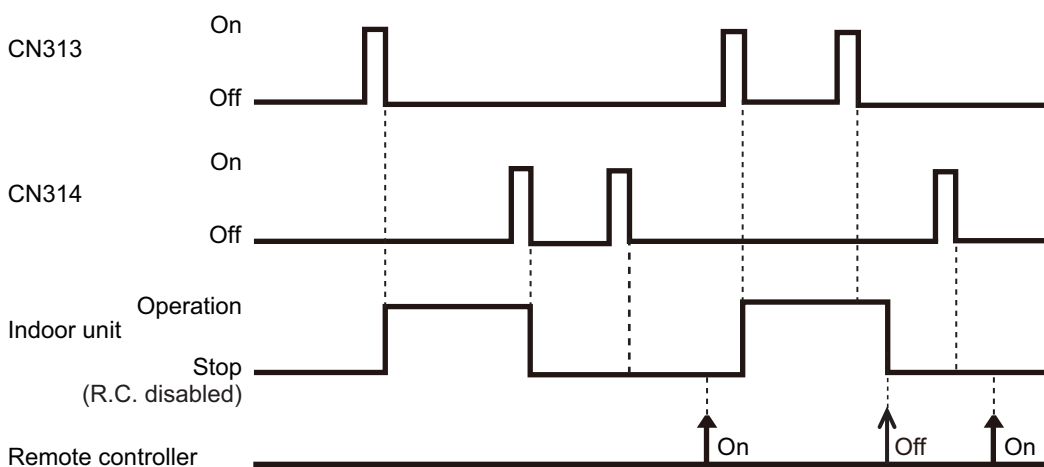

NOTE: When "Operation/Stop" mode 2 function is used with forming a remote controller group, connect the same equipment to each indoor unit within the group.

• Forced thermostat off function

Function setting /	Rotary SW on External input and output PCB	External input		Input signal	Command
60-00 / 2 60-09 / B 60-10 / C		External input and output PCB	CN313	Off → On	Thermostat off
				On → Off	Normal operation

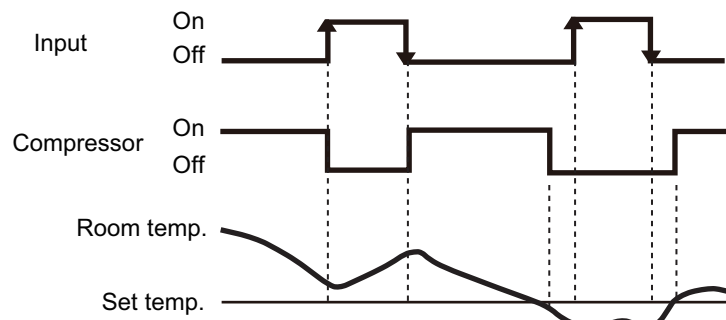

■ Control output function

• Operation/Stop status

Function setting /	Rotary SW on External input and output PCB	External output		Output signal	Command
60-00 / 1	External input and output PCB	CN310	Off → On	Operation	
			On → Off	Stop	

The output is low when the unit is stopped.

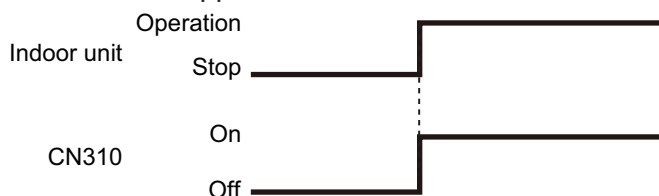

• Error status

Function setting /	Rotary SW on External input and output PCB	External output		Output signal	Command
60-00 / 1	External input and output PCB	CN311	Off → On	Error	
			On → Off	Normal	

The output is ON when an error is generated for the indoor unit.

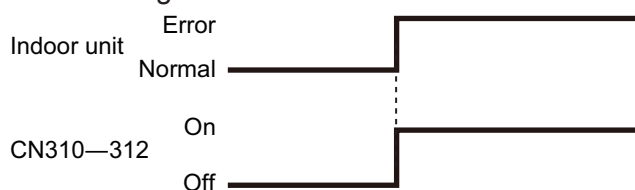

• Indoor unit fan operation status

Function setting /	Rotary SW on External input and output PCB	External output		Output signal	Command
60-00 / 1	External input and output PCB	CN312	Off → On	Fan run	
			On → Off	Fan stop	

Output signal	Condition
On Low → High	The indoor unit fan is operating.
Off High → Low	The fan is stopped or during cold air prevention. During thermostat off when in dry mode operation.

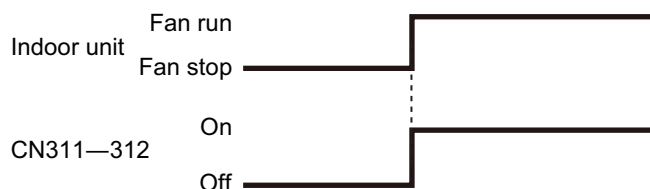

9. Group connection

Installation procedure for group control system:

A number of indoor units can be operated at the same time using a single remote controller.

NOTE: When different type of indoor units (such as wall mounted type and cassette type, cassette type and duct type, or other combinations) are connected using group control system, some functions may no longer be available.

1. Connect up to 16 indoor units in a system.

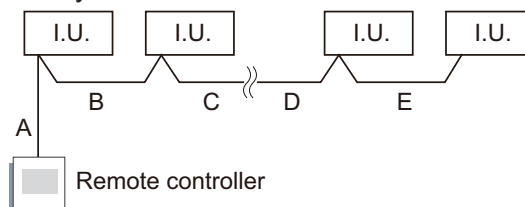

A, B, C, D, E: Remote controller cable

$A + B + C + D + E \leq 500 \text{ m}$

Example of wiring method

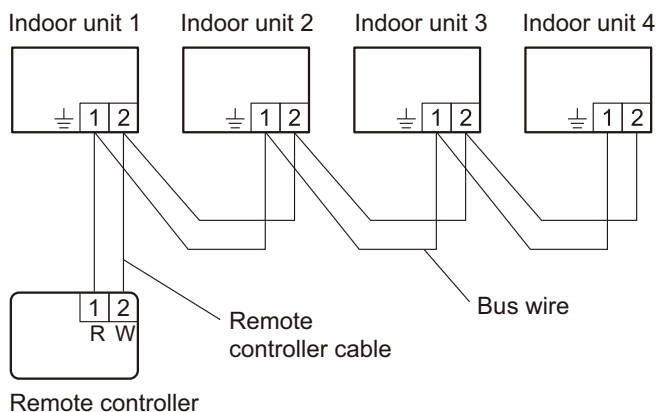

2. Set the R.C. address. (Function setting)

- Addresses will be automatically set when initially starting up this unit. In such a case, do not change the remote controller address for the indoor unit, and keep it at the initial setting of "00".
- Only set addresses manually when using different numbers for addresses. Set the R.C. address of each indoor unit using the function setting. (Refer to "Remote controller address setting" in ["Contents of function setting"](#) on page 35.)

NOTES:

- Do not use the same setting value.
- Setting is reflected after the power is turned on again.

Also set the R.C. address for the remote controller. For details, refer to the remote controller installation manual.

NOTE: In manual setting, connect up to 15 indoor units in a system.

Example of wiring method

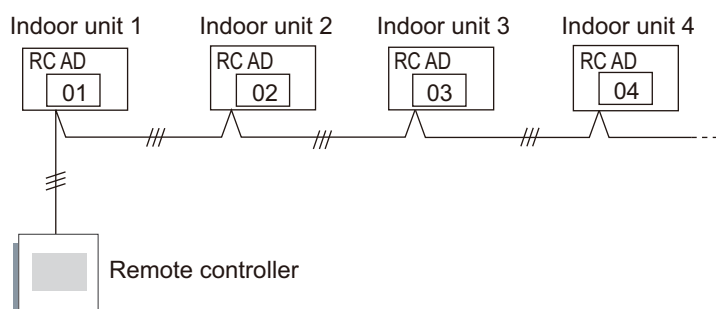

10. Remote controller

10-1. Wireless remote controller

Overview

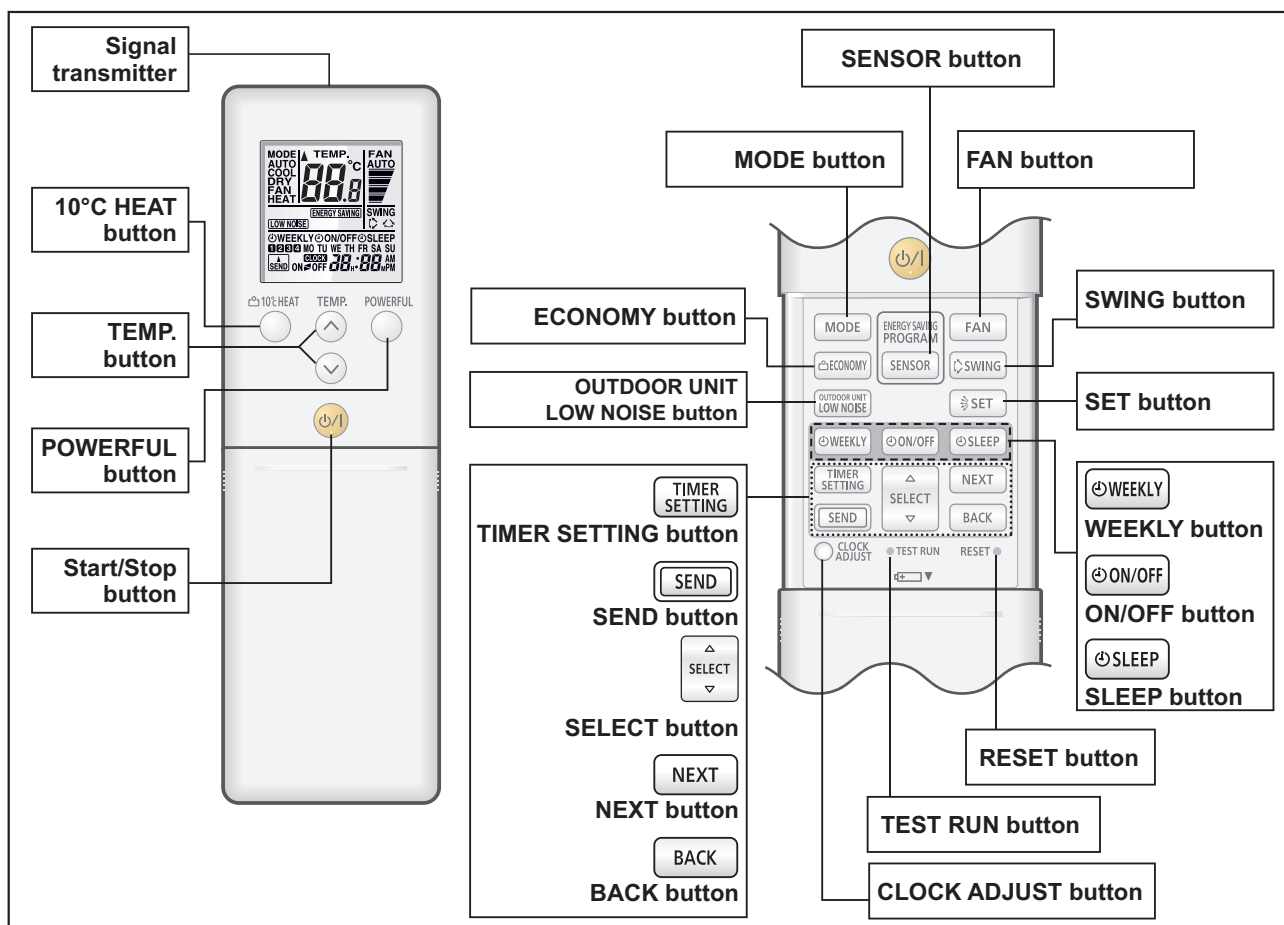

NOTE: Functions may differ by type of the indoor unit. For details, refer to the operation manual.

Display panel

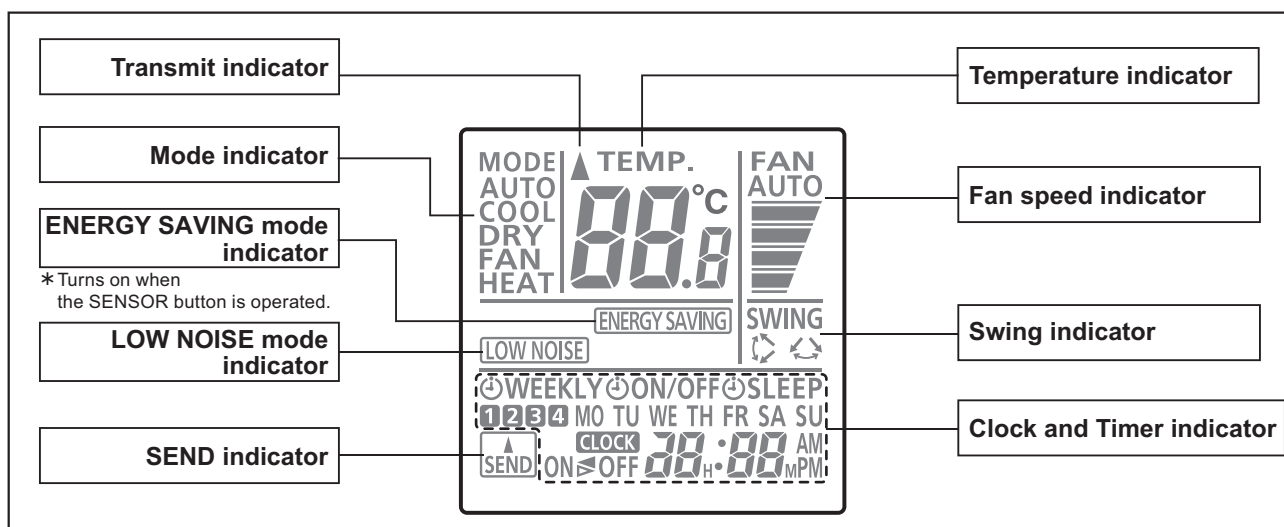

To facilitate explanation, the accompanying illustration has been drawn to show all possible indicators; in actual operation, however, the display will only show those indicators appropriate to the current operation.

■ Specifications

● Controller

Unit: mm

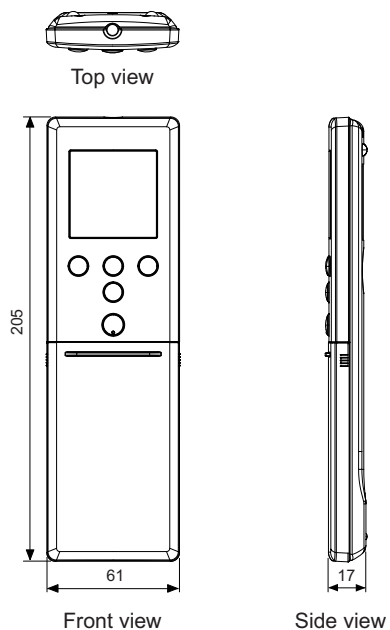

Size (H × W × D)	mm	205 × 61 × 17
Weight	g	122 (without batteries)

● Holder

Unit: mm

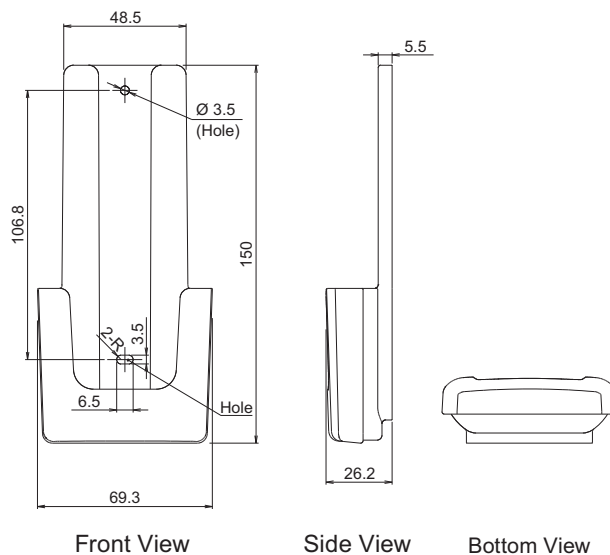

Size (H × W × D)	mm	150 × 69.3 × 26.2
Weight	g	27

11. Function settings

To adjust the functions of this product according to the installation environment, various types of function settings are available.

NOTE: Incorrect settings can cause a product malfunction.

11-1. Function settings by using remote controller

Some function settings can be changed on the remote controller. After confirming the setting procedure and the content of each function setting, select appropriate functions for your installation environment.

NOTE: Incorrect settings can cause a product malfunction.

■ Setting procedure by using wireless remote controller

The function number and the associated setting value are displayed on the LCD of the remote controller. Follow the instructions written in the local setup procedure supplied with the remote controller, and select appropriate setting according to the installation environment.

Before connecting the power supply of the indoor unit, reconfirm following items:

- Cover for the electrical enclosure on the outdoor unit is in place.
- There is no wiring mistake.
- Piping air tight test and vacuuming have been performed firmly.
- All the necessary wiring work for outdoor unit has been finished.

After reconfirming the items listed above, connect the power supply of the indoor unit.

NOTES:

- Settings will not be changed if invalid numbers or setting values are selected.
- When optional wired remote controller is used, refer to the installation manual enclosed with the remote controller.

Entering function setting mode:

While pressing the POWERFUL button and TEMP. (^) button simultaneously, press the RESET button to enter the function setting mode.

Selecting the function number and setting value:

1. Press the TEMP. (^) (v) buttons to select the function number. To switch between the left and right digits, press the 10 °C HEAT button.
2. Press the POWERFUL button to proceed to value setting. To return the function number selection, press the POWERFUL button again.
3. Press the TEMP. (^) (v) buttons to select the setting value. To switch between the left and right digits, press the 10 °C HEAT button.
4. Press the MODE button once to send the function setting information. Confirm that you hear the beep sound.
5. Press the START/STOP button to fix the function setting. Confirm that you hear the beep sound.
6. Press the RESET button to end the function setting mode.
7. After completing the function setting, be sure to disconnect the power supply and then reconnect it.



⚠ CAUTION

After disconnecting the power supply, wait 30 seconds or more before reconnecting it. The function setting will not become active unless the power supply is disconnected and then reconnected.

NOTES:

- The air conditioner custom code is set to **H** prior to shipment.
- If you do not know the air conditioner custom code setting, try each of the custom codes (**H** → **b** → **c** → **d**) until you find the code that operates the air conditioner.

■ Contents of function setting

Each function setting listed in this section is adjustable in accordance with the installation environment.

NOTE: Setting will not be changed if invalid numbers or setting values are selected.

● Function setting list

	Function no.	Functions
1)	00	Remote controller address setting
2)	11	Filter sign
3)	30/31	Room temperature control for indoor unit sensor
4)	35/36	Room temperature control for wired remote controller sensor
5)	40	Auto restart
6)	42	Room temperature sensor switching
7)	44	Remote controller custom code
8)	46	External input control
9)	48	Room temperature sensor switching (Aux.)
10)	49	Indoor unit fan control for energy saving for cooling
11)	60	Switching functions for external output terminal

1) Remote controller address setting

NOTE: Because this setting is normally done automatically when 2-wire-type wired remote controller is installed, setting is unnecessary.

Multiple indoor units can be operated by using one wired remote controller.

Set the unit number of each indoor unit.

Function number	Setting value	Setting description	Factory setting
00	00	Unit no. 0	◆
	01	Unit no. 1	
	02	Unit no. 2	
	03	Unit no. 3	
	04	Unit no. 4	
	05	Unit no. 5	
	06	Unit no. 6	
	07	Unit no. 7	
	08	Unit no. 8	
	09	Unit no. 9	
	10	Unit no. 10	
	11	Unit no. 11	
	12	Unit no. 12	
	13	Unit no. 13	
	14	Unit no. 14	
15	Unit no. 15		

NOTE: When different type of indoor units (such as wall mounted type and cassette type, cassette type and duct type, or other combinations) are connected using group control system, some functions may no longer be available.

2) Filter sign

Select appropriate intervals for displaying the filter sign on the indoor unit according to the estimated amount of dust in the air of the room.

If the indication is not required, select "No indication" (03).

Function number	Setting value	Setting description	Factory setting
11	00	Standard (400 hours)	
	01	Long interval (1,000 hours)	
	02	Short interval (200 hours)	
	03	No indication	◆

3) Room temperature control for indoor unit sensor

Depending on the installed environment, correction of the room temperature sensor may be required. Select the appropriate control setting according to the installed environment.

The temperature correction values show the difference from the Standard setting "00" (manufacturer's recommended value).

Function number	Setting value	Setting description	Factory setting		
30 (For cooling)	31 (For heating)	00	Standard setting	◆	
		01	No correction 0.0 °C		
		02	-0.5 °C	More cooling Less heating	
		03	-1.0 °C		
		04	-1.5 °C		
		05	-2.0 °C		
		06	-2.5 °C		
		07	-3.0 °C		
		08	-3.5 °C		
		09	-4.0 °C		
		10	+0.5 °C	Less cooling More heating	
		11	+1.0 °C		
		12	+1.5 °C		
		13	+2.0 °C		
		14	+2.5 °C		
		15	+3.0 °C		
		16	+3.5 °C		
17	+4.0 °C				

4) Room temperature control for wired remote controller sensor

Depending on the installed environment, correction of the wire remote temperature sensor may be required. Select the appropriate control setting according to the installed environment.

To change this setting, set Function 42 to Both "01".

Ensure that the Thermo Sensor icon is displayed on the remote controller screen.

Function number		Setting value	Setting description	Factory setting	
35 (For cooling)	36 (For heating)	00	No correction	◆	
		01	No correction 0.0°C		
		02	-0.5 °C	More cooling Less heating	
		03	-1.0 °C		
		04	-1.5 °C		
		05	-2.0 °C		
		06	-2.5 °C		
		07	-3.0 °C		
		08	-3.5 °C		
		09	-4.0 °C		
		10	+0.5 °C	Less cooling More heating	
		11	+1.0 °C		
		12	+1.5 °C		
		13	+2.0 °C		
		14	+2.5 °C		
		15	+3.0 °C		
		16	+3.5 °C		
17	+4.0 °C				

5) Auto restart

Enables or disables automatic restart after a power interruption.

Function number	Setting value	Setting description	Factory setting
40	00	Enable	◆
	01	Disable	

NOTE: Auto restart is an emergency function such as for power outage etc. Do not attempt to use this function in normal operation. Be sure to operate the unit by remote controller or external device.

6) Room temperature sensor switching

(Only for wired remote controller)

When using the wired remote controller temperature sensor, change the setting to "Both" (01).

Function number	Setting value	Setting description	Factory setting
42	00	Indoor unit	◆
	01	Both	

00: Sensor on the indoor unit is active.

01: Sensors on both indoor unit and wired remote controller are active.

NOTE: Remote controller sensor must be turned on by using the remote controller.

7) Remote controller custom code

(Only for wireless remote controller)

The indoor unit custom code can be changed. Select the appropriate custom code.

Function number	Setting value	Setting description	Factory setting
44	00	A	◆
	01	B	
	02	C	
	03	D	

8) External input control

"Operation/Stop" mode or "Forced stop" mode can be selected.

Function number	Setting value	Setting description	Factory setting
46	00	Operation/Stop mode 1	◆
	01	(Setting prohibited)	
	02	Forced stop mode	
	03	Operation/Stop mode 2	

9) Room temperature sensor switching (Aux.)

To use the temperature sensor on the wired remote controller only, change the setting to "Wired remote controller" (01).

This function will only work if the function setting 42 is set at "Both" (01).

When the setting value is set to "Both" (00), more suitable control of the room temperature is possible by setting function setting 30 and 31 too.

Function number	Setting value	Setting description	Factory setting
48	00	Both	◆
	01	Wired remote controller	

10) Indoor unit fan control for energy saving for cooling

Enables or disables the power-saving function by controlling the indoor unit fan rotation when the outdoor unit is stopped during cooling operation.

Function number	Setting value	Setting description	Factory setting
49	00	Disable	
	01	Enable	
	02	Remote controller	◆

00: When the outdoor unit is stopped, the indoor unit fan operates continuously following the setting on the remote controller.

01: When the outdoor unit is stopped, the indoor unit fan operates intermittently at a very low speed.

02: Enable or disable this function by remote controller setting.

NOTES:

- As the factory setting, this setting is initially activated.
- Set to "00" or "01" when connecting a remote controller that cannot set the Fan control for energy saving function or connecting a network converter.
To confirm if the remote controller has this setting, refer to the operating manual of each remote controller.

11) Switching functions for external output terminal

Functions of the external output terminal can be switched. For details, refer to “External input and output”.

Function number	Setting value	Setting description	Factory setting
60	00	Operation status	◆
	09	Error status	
	10	Indoor unit fan operation status	

11-2. Custom code setting for wireless remote controller

To interconnect the air conditioner and the wireless remote controller, assignment of the custom code for the wireless remote controller is required.

NOTE: Air conditioner cannot receive a signal if the air conditioner has not been set for the custom code.

When 2 or more air conditioners are installed in a room, and the remote controller is operating an air conditioner other than the one you wish to set, change the custom code of the remote controller to operate only the air conditioner you wish to set. (4 selections possible.)

Confirm the setting of the remote controller custom code and the function setting. If these do not match, the remote controller cannot be used to operate for the air conditioner.

1. Press the START/STOP button until only the clock is displayed on the remote controller display.
2. Press the MODE button for at least 5 seconds to display the current custom code. (Initially set to A .)
3. Press the TEMP. (\wedge) (\vee) buttons to change the custom code between $\text{A} \rightarrow \text{b} \rightarrow \text{c} \rightarrow \text{d}$. Match the code on the display to the air conditioner custom code. (Initially set to A .)
4. Press the MODE button again to return to the clock display. The custom code will be changed.











NOTES:

- If no button is pressed within 30 seconds after the custom code is displayed, the system returns to the original clock indicator. In this case, start again from step 1.
- The air conditioner custom code is set to A prior to shipment. To change the custom code, contact your retailer.
- If you do not know the assigned code for the air conditioner, try each of the custom code ($\text{A} \rightarrow \text{b} \rightarrow \text{c} \rightarrow \text{d}$) until you find the code which operates the air conditioner.

12. Accessories

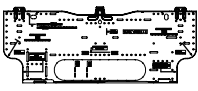
12-1. Models: ASYG07KGTA, ASYG09KGTA, ASYG12KGTA, and ASYG14KGTA

Part name	Exterior	Q'ty	Part name	Exterior	Q'ty
Operating manual		1	Cloth tape		1
Installation manual		1	Tapping screw (Large)		5
Operating manual (CD ROM)		1	Tapping screw (Small)		2
Remote controller		1	Wall hook bracket		1
Battery		2			
Remote controller holder		1			



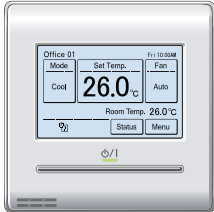
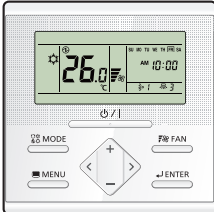

13. Optional parts

13-1. Controllers

Exterior	Part name	Model name	Summary
	Wired remote controller	UTY-RNRYZ*	Easy finger touch operation with LCD panel. Backlit LCD enables easy operation in a dark room. Wire type: Non-polar 2-wire Optional communication kit is necessary for installation.
	Wired remote controller	UTY-RLRY	High visibility and easy operation. Room temperature can be accurately controlled using the built-in thermo sensor. Wire type: Non-polar 2-wire Optional communication kit is necessary for installation.

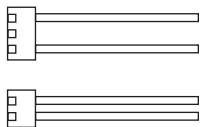
NOTE: Available functions may differ by the remote controller. For details, refer to the operation manual.

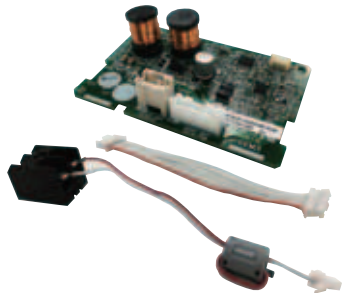
13-2. Others

Exterior	Part name	Model name	Summary
	External connect kit	UTY-XWZX	Use to connect with various peripheral devices and air conditioner PCB.
	External input and output PCB	UTY-XCSXZ2	Use to connect with external devices and air conditioner PCB.
	Communication kit	UTY-TWRXZ2	Use to connect Non-polar 2-core wired remote controller.
	Wireless LAN adapter	UTY-TFSXW1	Remotely manage an air conditioning system using mobile devices such as smartphones and tablets.

Part 2. OUTDOOR UNIT

SINGLE TYPE:

AOYG07KGCA

AOYG09KGCA

AOYG12KGCA

AOYG14KGCA

1. Specifications

OUTDOOR UNIT
AOYG07-14KGCA

Type				Inverter heat pump				
Model name				AOYG07KGCA	AOYG09KGCA	AOYG12KGCA	AOYG14KGCA	
Power supply				230 V ~ 50 Hz				
Available voltage range				198—264 V				
Starting current				A	2.8	3.5	4.8	6.4
Fan	Airflow rate	Cooling	m ³ /h	1,610	1,610	1,680	1,680	
		Heating		1,560	1,610	1,580	1,580	
	Type × Q'ty	Propeller fan × 1						
Motor output				W	21			
Sound pressure level *1		Cooling	dB (A)	46		50		
		Heating		46	48	50		
Sound power level		Cooling	dB (A)	61		65		
		Heating		62	63	66		
Heat exchanger type	Dimensions (H × W × D)		mm	504 × 688 × 249				
	Fin pitch			1.3				
	Rows × Stages		1.5 × 24		2 × 24			
	Pipe type		Copper					
	Fin type		Type (Material)	Corrugate (Aluminum)				
		Surface treatment	Corrosion resistance					
Compressor	Type × Q'ty		W	Rotary × 1				
	Motor output			900				
Refrigerant	Type (Global warming potential)		R32 (675)					
	Charge		g	750		850		
Refrigerant oil	Type		RB68A					
	Amount		cm ³	340				
Enclosure	Material		Steel sheet					
	Color		Beige					
Dimensions (H × W × D)	Net		mm	542 × 799 × 290				
	Gross			602 × 940 × 375				
Weight	Net		kg	30		31		32
	Gross			34		35		36
Connection pipe	Size	Liquid	mm (in)	Ø 6.35 (Ø 1/4)				
		Gas		Ø 9.52 (Ø 3/8)				
	Method		Flare					
	Pre-charge length		15					
	Max. length		m	20				
Max. height difference		15						
Operation range		Cooling	°C	-10 to 46				
		Heating		-15 to 24				
Drain hose	Material		PP+LLDPE					
	Size		mm	Ø 13.0 (I. D.), Ø 16.0 to Ø 16.8 (O. D.)				
NOTES:								
<ul style="list-style-type: none"> • Specifications are based on the following conditions: <ul style="list-style-type: none"> – Cooling: Indoor temperature of 27 °CDB/19 °CWB, and outdoor temperature of 35 °CDB/24 °CWB. – Heating: Indoor temperature of 20 °CDB/15 °CWB, and outdoor temperature of 7 °CDB/6 °CWB. – Pipe length: 5 m, Height difference: 0 m. • Protective function might work when using it outside the operation range. • *1: Sound pressure level <ul style="list-style-type: none"> – Measured values in manufacturer's anechoic chamber. – Because of the surrounding sound environment, the sound levels measured in actual installation conditions might be higher than the specified values here. 								

2. Dimensions

2-1. Models: AOYG07KGCA, AOYG09KGCA, AOYG12KGCA, and AOYG14KGCA

Unit: mm

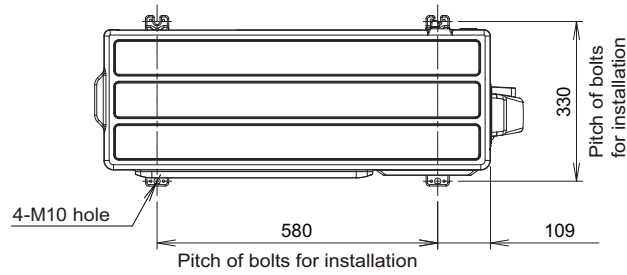

Top view

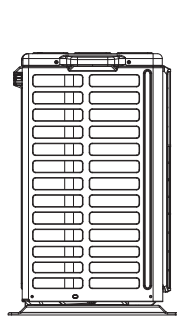

Side view

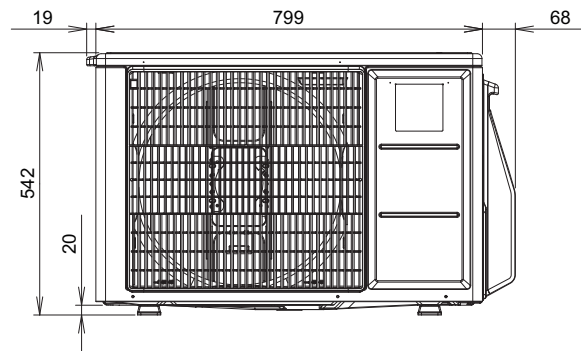

Front view

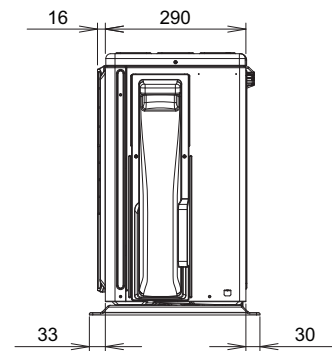

Side view

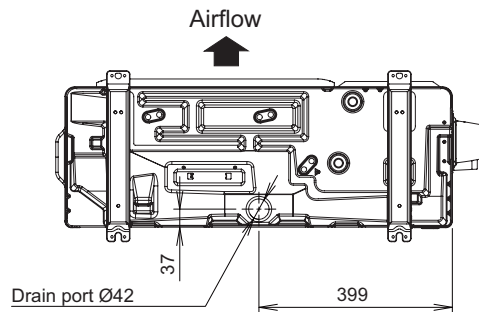

Bottom view

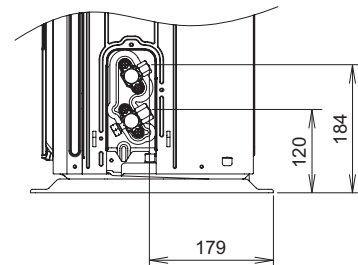

Side view (Bulb part)

3. Installation space

3-1. Models: AOYG07KGCA, AOYG09KGCA, AOYG12KGCA, and AOYG14KGCA

■ Space requirement

Provide sufficient installation space for product safety.

⚠ CAUTION

Keep the space shown in the installation examples.

If the installation is not performed accordingly, it could cause a short circuit and result in a lack of operating performance.

● Single outdoor unit installation

- When the upper space is open:

Unit: mm

Obstacles at rear only

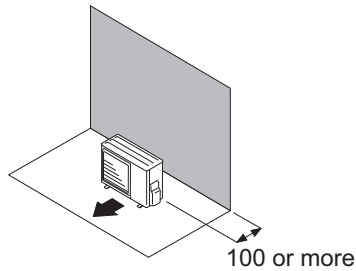

Obstacles at rear and sides

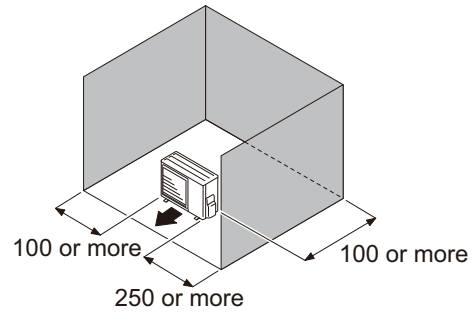

Obstacles at front

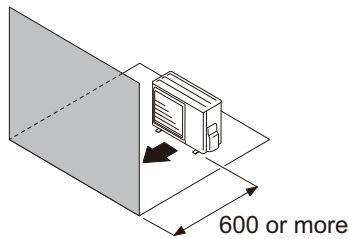

Obstacles at front and rear

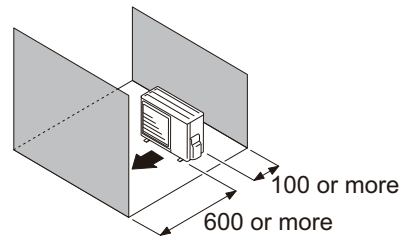

- When there is an obstruction in the upper space:

Unit: mm

Obstacles at rear and above

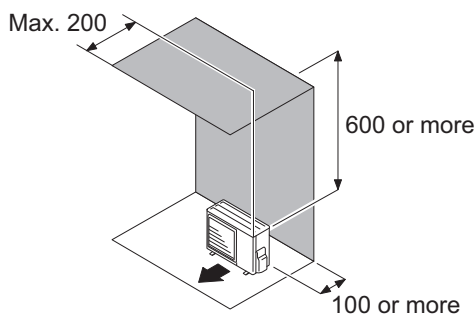

Obstacles at rear, sides, and above

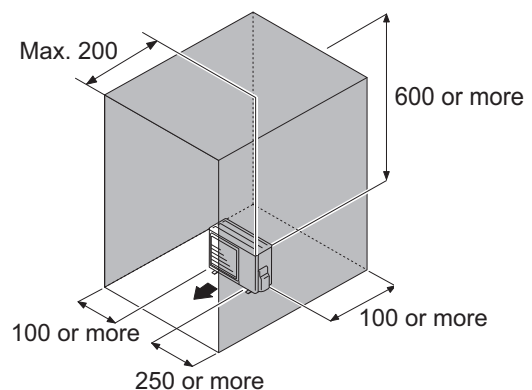

● Multiple outdoor unit installation

- Provide at least 250 mm of space between the outdoor units if multiple units are installed.
- When routing the piping from the side of an outdoor unit, provide space for piping.
- No more than 3 units must be installed side by side.
When 3 units or more are arranged in a line, provide the space as shown in the following example “When an obstruction in the upper space:”.

- **When the upper space is open:**

Unit: mm

Obstacles at rear only

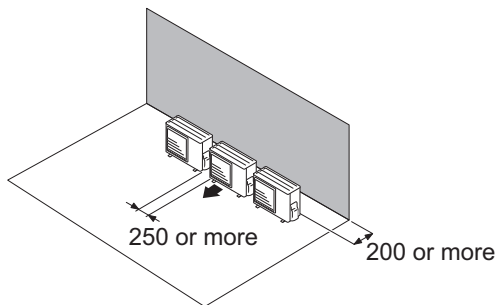

Obstacles at front only

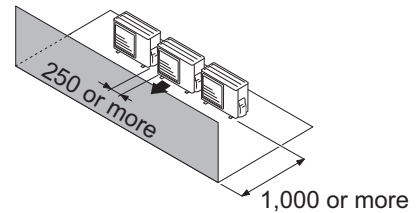

Obstacles at front and rear

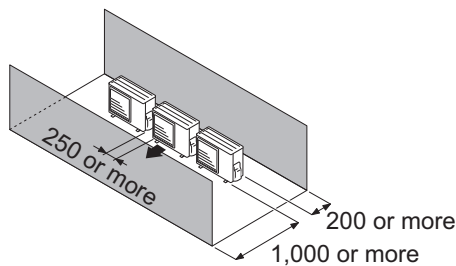

- **When an obstruction in the upper space:**

Unit: mm

Obstacles at rear and above.

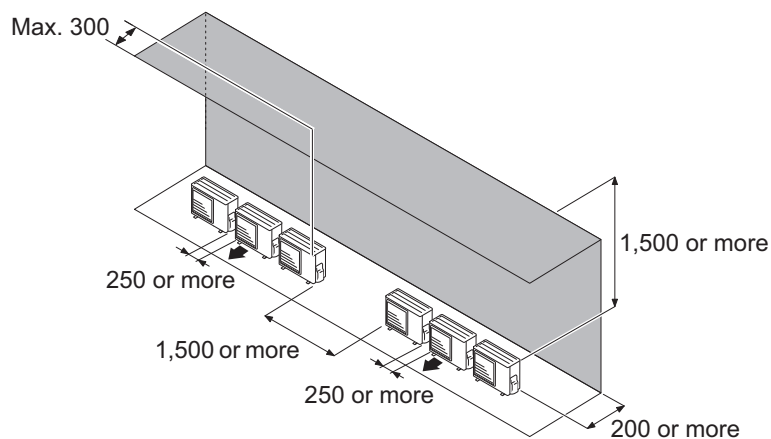

● Outdoor units installation in multi-row

Unit: mm

Single parallel unit arrangement

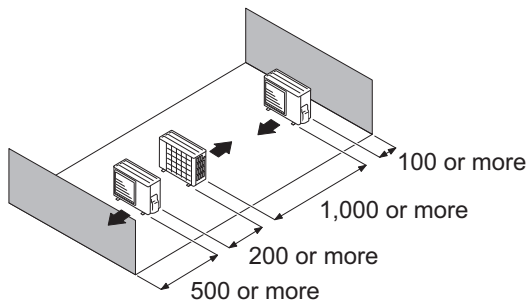

Multiple parallel unit arrangement

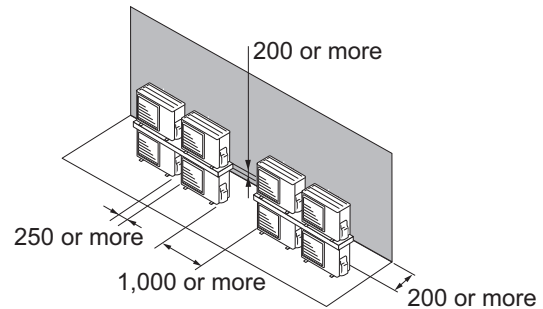
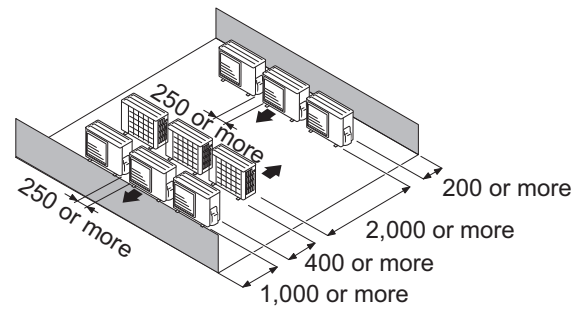

NOTES:

- If the space is larger than stated above, the condition will be the same as when there is no obstacle.
- When installing the outdoor unit, be sure to open the front and left side to obtain better operation efficiency.

⚠ CAUTION

- Do not install the outdoor unit in two-stage where the drain water could freeze. Otherwise the drainage from the upper unit may form ice and cause a malfunction of the lower unit.
- When the outdoor temperature is 0 °C or less, do not use the accessory drain pipe and drain cap. If the drain pipe and drain cap are used, the drain water in the pipe may freeze in extremely cold climate. (For reverse cycle model only.)
- In area with heavy snowfall, if the inlet and outlet of the outdoor unit is blocked with snow, it might become difficult to get warm, and it is likely to cause product malfunction. Construct a canopy and a pedestal, or place the unit on a high stand that is locally installed.

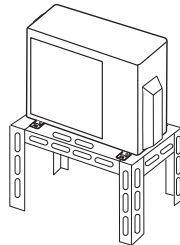

4. Refrigerant circuit

4-1. Models: AOYG07KGCA, AOYG09KGCA, AOYG12KGCA, and AOYG14KGCA

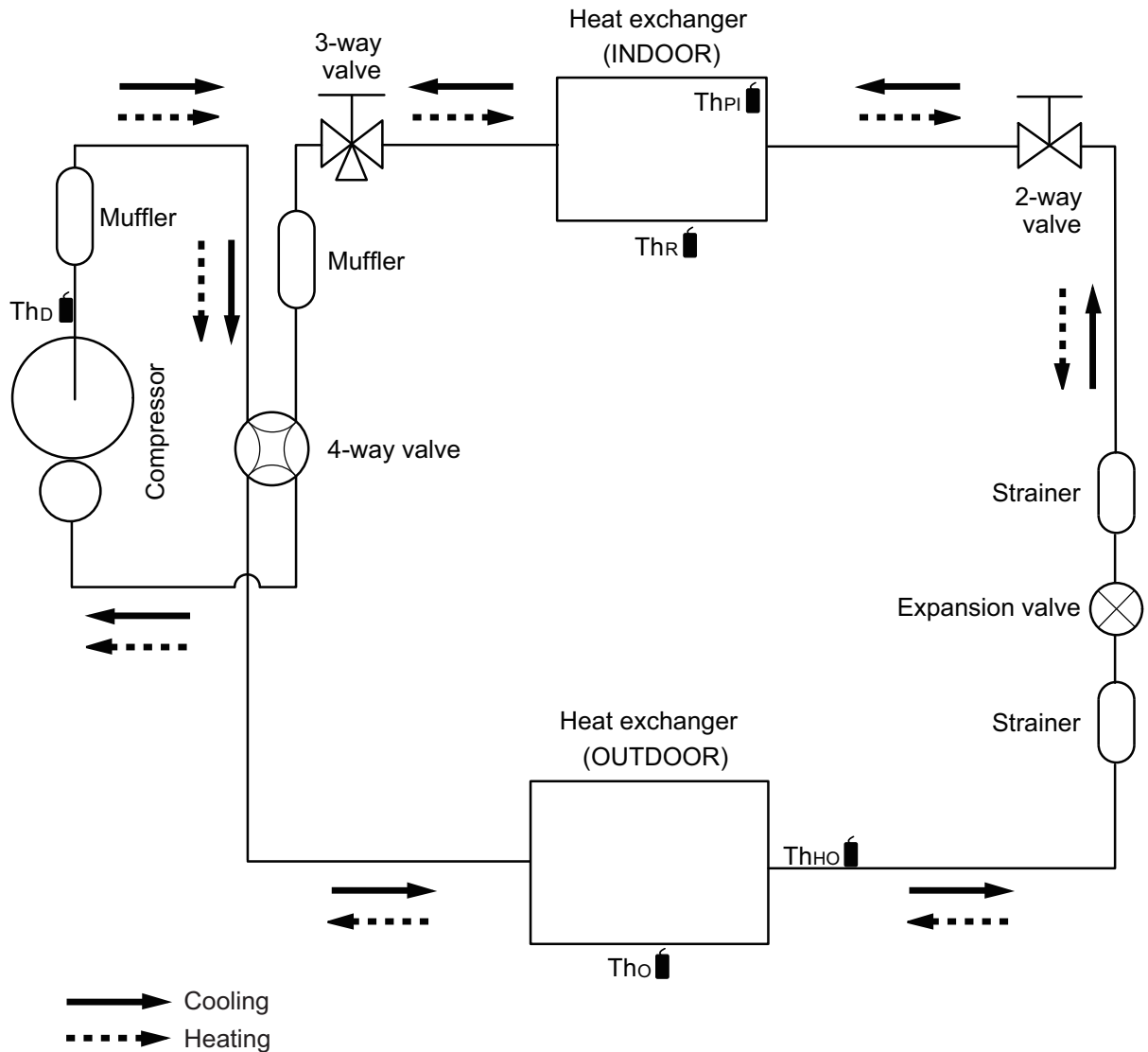

Th_D : Thermistor (Discharge temperature)

Th_O : Thermistor (Outdoor temperature)

Th_{HO} : Thermistor (Heat exchanger out temperature)

Th_R : Thermistor (Room temperature)

Th_{PI} : Thermistor (Pipe temperature)

5. Wiring diagrams

5-1. Models: AOYG07KGCA, AOYG09KGCA, AOYG12KGCA, and AOYG14KGCA

OUTDOOR UNIT
AOYG07-14KGCA

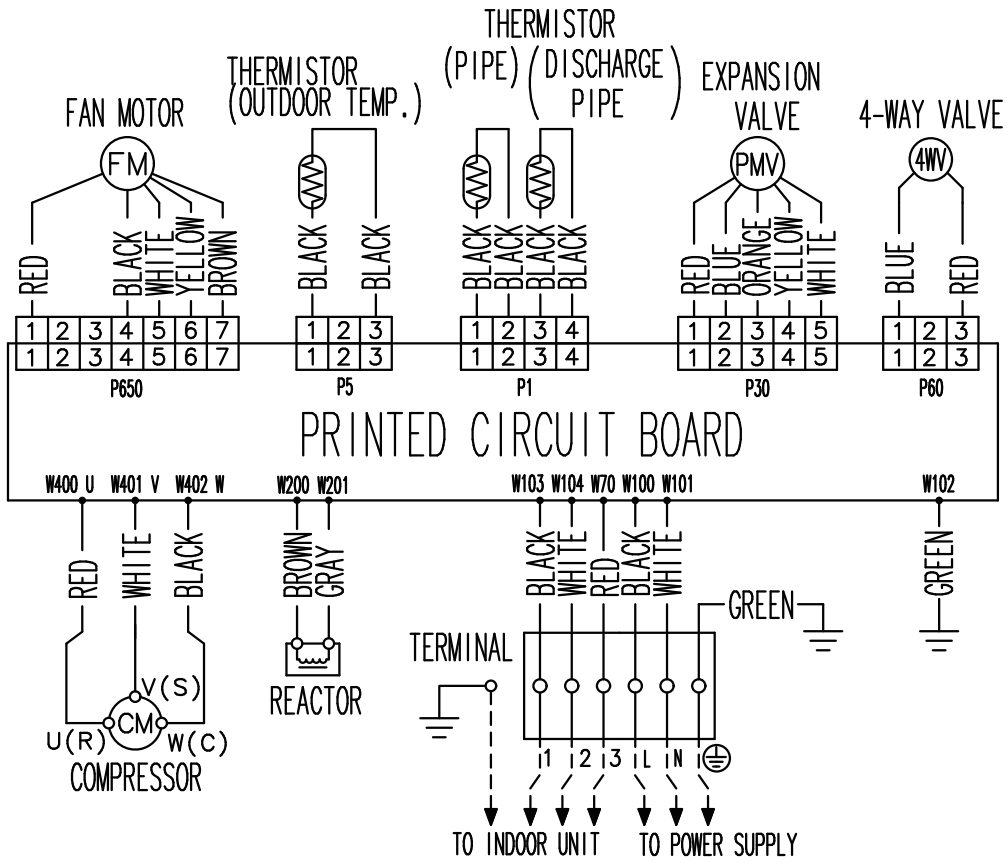

6. Capacity compensation rate for pipe length and height difference

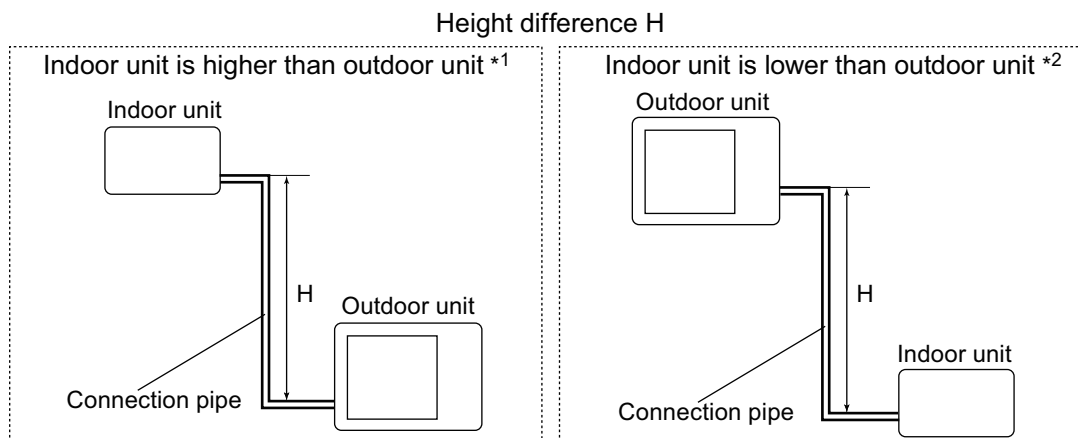

6-1. Models: AOYG07KGCA, AOYG09KGCA, AOYG12KGCA, and AOYG14KGCA

NOTE: Values mentioned in the table are calculated based on the maximum capacity.

COOLING			Pipe length (m)				
			5	7.5	10	15	20
Height difference H (m)	Indoor unit is higher than outdoor unit *1	15	—	—	—	0.858	0.868
		10	—	—	0.929	0.872	0.882
		7.5	—	0.960	0.933	0.876	0.885
		5	0.992	0.964	0.937	0.879	0.889
	Indoor unit is lower than outdoor unit *2	0	1.000	0.972	0.944	0.887	0.896
		-5	1.000	0.972	0.944	0.887	0.896
		-7.5	—	0.972	0.944	0.887	0.896
		-10	—	—	0.944	0.887	0.896
		-15	—	—	—	0.887	0.896

HEATING			Pipe length (m)				
			5	7.5	10	15	20
Height difference H (m)	Indoor unit is higher than outdoor unit *1	15	—	—	—	0.896	0.879
		10	—	—	0.968	0.890	0.879
		7.5	—	0.994	0.968	0.896	0.879
		5	1.000	0.994	0.968	0.896	0.879
	Indoor unit is lower than outdoor unit *2	0	1.000	0.994	0.968	0.896	0.879
		-5	0.995	0.989	0.963	0.891	0.875
		-7.5	—	0.987	0.961	0.889	0.873
		-10	—	—	0.959	0.887	0.871
		-15	—	—	—	0.878	0.862

7. Additional charge calculation

7-1. Models: AOYG07KGCA and AOYG09KGCA

Refrigerant type		R32
Refrigerant amount	g	750

■ Refrigerant charge

Total pipe length	m	15 or less	20 (Max.)	20 g/m
Additional charge	g	0	100	

7-2. Models: AOYG12KGCA and AOYG14KGCA

Refrigerant type		R32
Refrigerant amount	g	850

■ Refrigerant charge

Total pipe length	m	15 or less	20 (Max.)	20 g/m
Additional charge	g	0	100	

8. Airflow

8-1. Model: AOYG07KGCA

● Cooling

m ³ /h	1,610
l/s	447
CFM	948

● Heating

m ³ /h	1,560
l/s	433
CFM	918

8-2. Model: AOYG09KGCA

● Cooling

m ³ /h	1,610
l/s	447
CFM	948

● Heating

m ³ /h	1,610
l/s	447
CFM	948

8-3. Model: AOYG12KGCA

● Cooling

m ³ /h	1,680
l/s	467
CFM	989

● Heating

m ³ /h	1,580
l/s	439
CFM	930

8-4. Model: AOYG14KGCA

● Cooling

m ³ /h	1,680
l/s	467
CFM	989

● Heating

m ³ /h	1,580
l/s	439
CFM	930

9. Operation noise (sound pressure)

9-1. Noise level curve

Model: AOYG07KGCA

Cooling

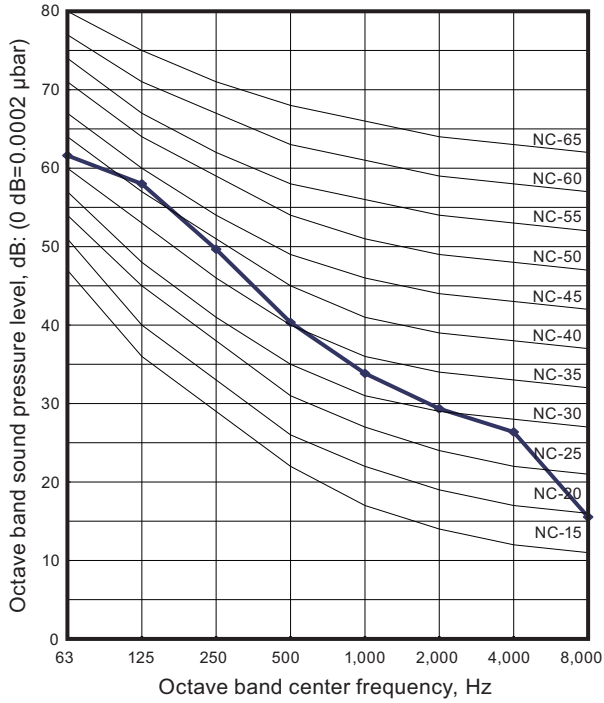

Heating

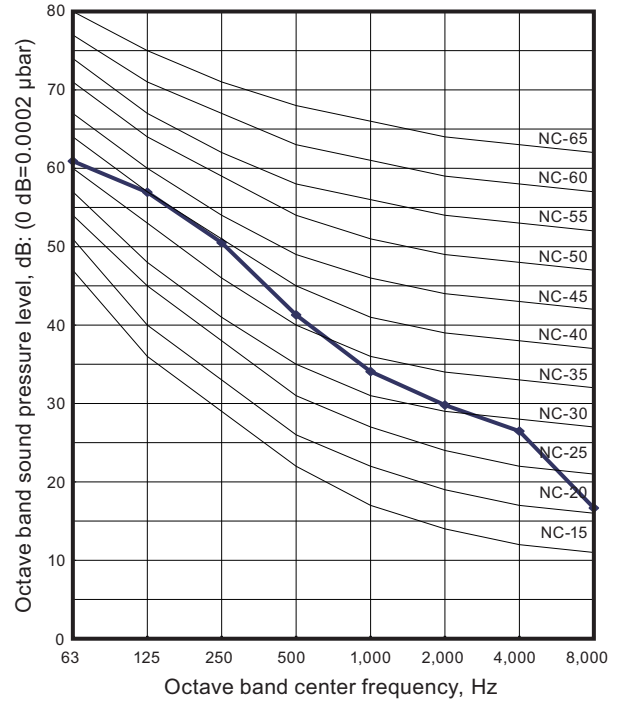

Model: AOYG09KGCA

Cooling

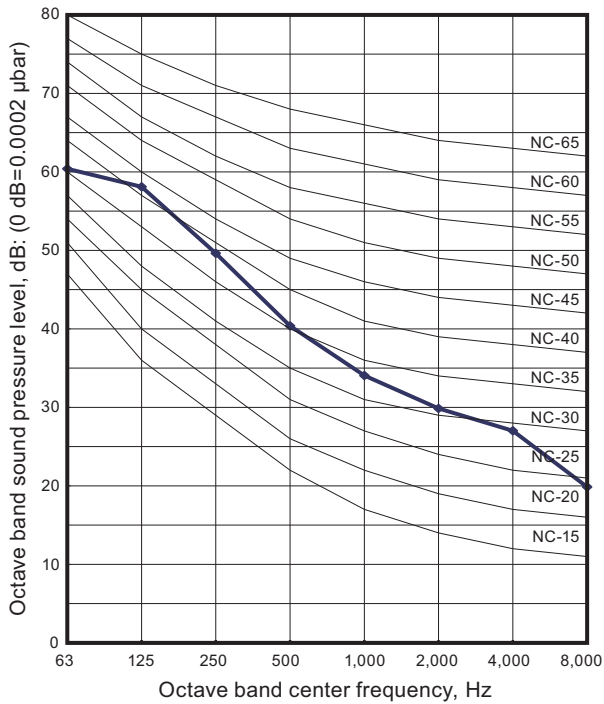

Heating

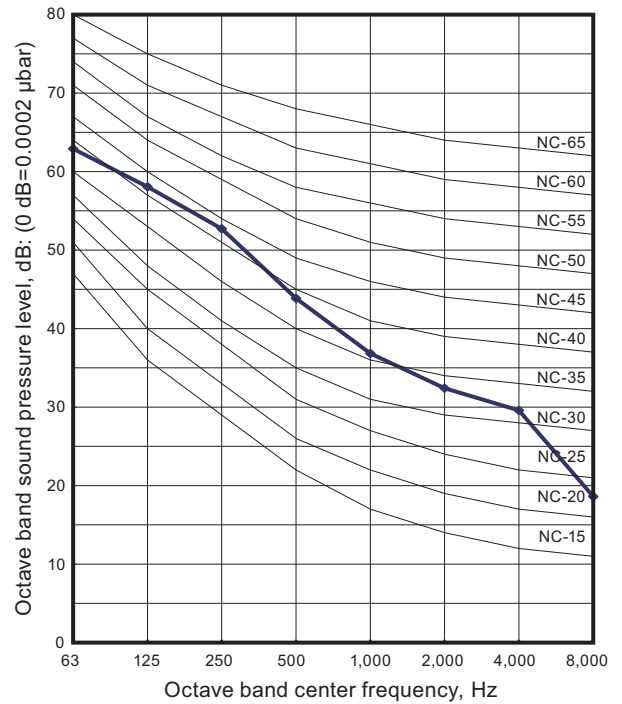

OUTDOOR UNIT
AOYG07-14KGCA

Model: AOYG12KGCA

Cooling

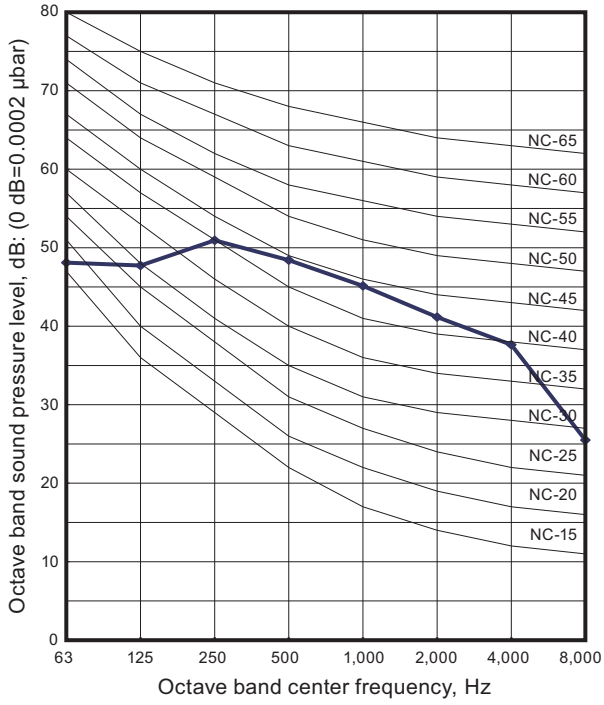

Heating

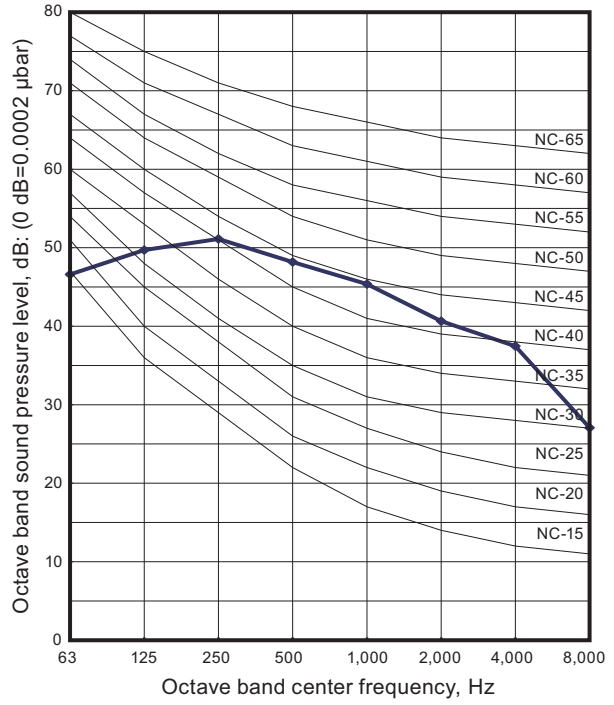

Model: AOYG14KGCA

Cooling

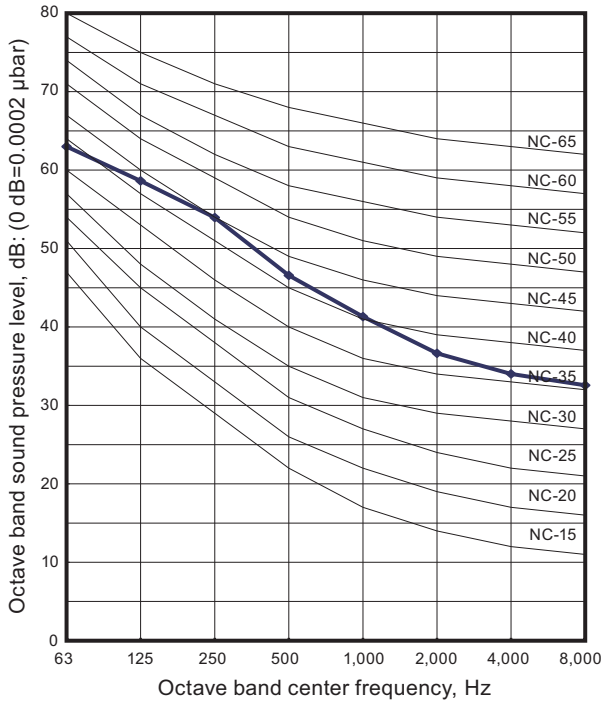

Heating

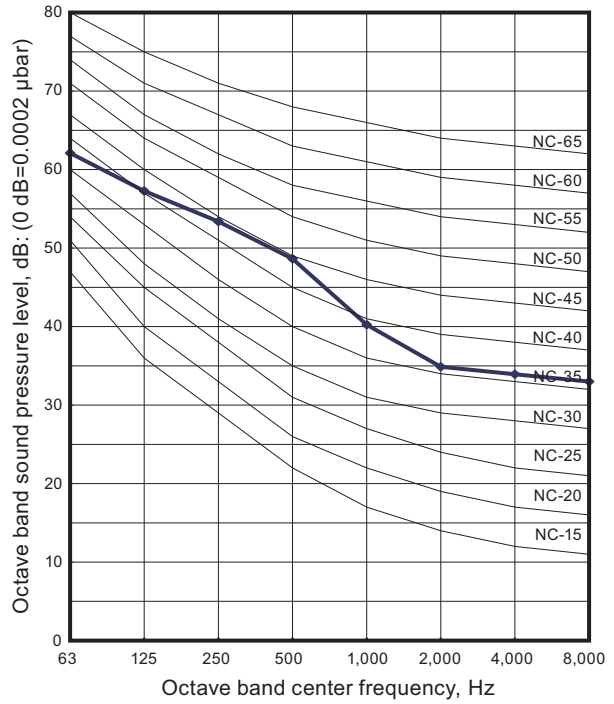

OUTDOOR UNIT
AOYG07-14KGCA

9-2. Sound level check point

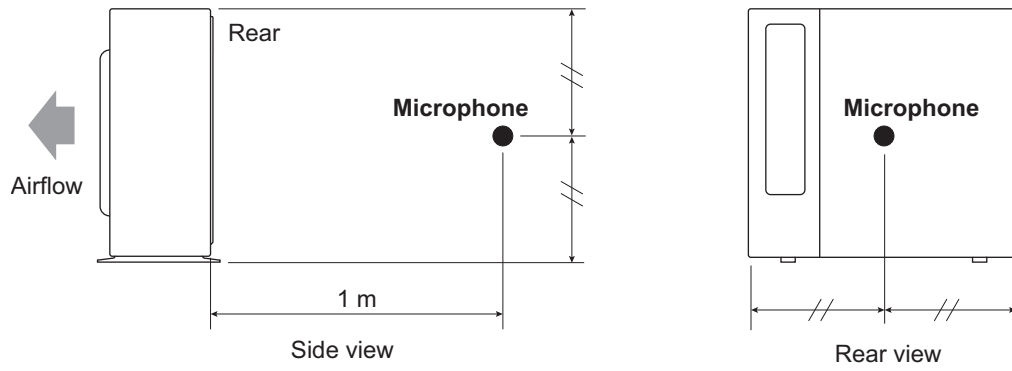

NOTE: Detailed shape of the actual outdoor unit might be slightly different from the one illustrated above.

10. Electrical characteristics

Model name			AOYG07KGCA	AOYG09KGCA	AOYG12KGCA	AOYG14KGCA
Power supply	Voltage	V	230 ~			
	Frequency	Hz	50			
Max operating current *1		A	9.0			10.5
Starting current		A	2.8	3.5	4.8	6.4
Wiring spec. *2	Circuit breaker current	A	15			
	Power cable	mm ²	1.5			
	Connection cable *3	mm ²	1.5			
	Limited wiring length	m	21			

*1: Maximum current is the total current of the indoor unit and the outdoor unit.

*2: Selected sample based on Japan Electrotechnical Standards and Codes Committee E0005. As the regulations of wire size and circuit breaker differ in each country or region, select appropriate devices complied to the regional standard.

*3: Limit voltage drop to less than 2%. If voltage drop is 2% or more, increase cable conductor size.



11. Safety devices

Type of protection	Protection form		Model	
			AOYG07KGCA	AOYG09KGCA
Circuit protection	Current fuse (Main PCB)		250 V, 20 A	
			250 V, 5 A	
Fan motor protection	Terminal protection program	Activate	125±25 °C Fan motor stop	
		Reset	100±25 °C Fan motor restart	
Compressor protection	Terminal protection program (Discharge temp.)	Activate	110 °C Compressor stop	
		Reset	After 7 minutes Compressor restart	

Type of protection	Protection form		Model	
			AOYG12KGCA	AOYG14KGCA
Circuit protection	Current fuse (Main PCB)		250 V, 20 A	
			250 V, 5 A	
Fan motor protection	Terminal protection program	Activate	125±25 °C Fan motor stop	
		Reset	100±25 °C Fan motor restart	
Compressor protection	Terminal protection program (Discharge temp.)	Activate	110 °C Compressor stop	
		Reset	After 7 minutes Compressor restart	

12. Accessories

12-1. Models: AOYG07KGCA, AOYG09KGCA, AOYG12KGCA, and AOYG14KGCA

Part name	Exterior	Q'ty	Part name	Exterior	Q'ty
Installation manual		1	Drain pipe		1