

SPLIT TYPE
ROOM AIR CONDITIONER
WALL MOUNTED TYPE

SERVICE MANUAL



Indoor unit	Outdoor unit
ASYG09LTCA	AOYG09LTC

CONTENTS

SPECIFICATIONS.....	1
DIMENSIONS.....	2
REFRIGERANT SYSTEM DIAGRAM... ..	3
CIRCUIT DIAGRAM.....	4
INDOOR PCB CIRCUIT DIAGRAM.....	5
OUTDOOR PCB CIRCUIT DIAGRAM... ..	8
ERROR DETECTION.....	10
PARTS (INDOOR UNIT).....	12
PARTS (OUTDOOR UNIT).....	17
ACCESSORIES.....	20

SPECIFICATIONS

ELECTRICAL DATA

TYPE	Cool & heat inverter	
INDOOR UNIT	ASYG09LTCA	
OUTDOOR UNIT	AOYG09LTC	
COOLING CAPACITY	2.50 kW	
HEATING CAPACITY	3.20 kW	
POWER SOURCE	230 V	
FREQUENCY	50 Hz	
RUNNING CURRENT	Cooling	3.5 A
	Heating	3.8 A
INPUT WATTS	Cooling	0.640 kW
	Heating	0.750 kW
E.E.R.	Cooling	3.91 kW/kW
COP	Heating	4.27 kW/kW
MOISTURE REMOVAL	1.3 L/h	
AIR CIRCULATION HIGH	Cooling	690 m ³ /h
	Heating	710 m ³ /h
MAXIMUM CURRENT	Cooling	6.0 A
	Heating	7.5 A

FAN MOTOR

POWER SOURCE	230 V	
INDOOR UNIT Cooling	High speed	1,400 r.p.m.
	Middle speed	1,200 r.p.m.
	Low speed	920 r.p.m.
	Quiet	620 r.p.m.
INDOOR UNIT Heating	High speed	1,440 r.p.m.
	Middle speed	1,200 r.p.m.
	Low speed	980 r.p.m.
	Quiet	670 r.p.m.
OUTDOOR UNIT Cooling	730 r.p.m.	
OUTDOOR UNIT Heating	650 r.p.m.	

NOISE LEVEL

INDOOR UNIT Cooling	High speed	43 dB
	Middle speed	38 dB
	Low speed	31 dB
	Quiet	21 dB
INDOOR UNIT Heating	High speed	43 dB
	Middle speed	38 dB
	Low speed	31 dB
	Quiet	21 dB
OUTDOOR UNIT Cooling	45 dB	
OUTDOOR UNIT Heating	45 dB	

COMPRESSOR AND REFRIGERANT

COMPRESSOR TYPE	Hermetic type, 4 pole, 3 phase, DC inverter motor, Rotary	
DISCRIMINATION	5SS072XAA	
WEIGHT (with oil)	5.9 kg	
PRECHARGED REFRIGERANT	850 g	
REFRIGERANT TYPE	R410A	
FULL CHARGE	Pipe length 15 m	650 g
	20 m	750 g
ADDITIONAL REFRIGERANT	20 g/m	
MAXIMUM PIPING HEIGHT	15m	

DIMENSIONS

INDOOR UNIT	H x W x D	260 x 790 x 198 mm
OUTDOOR UNIT	H x W x D	540 x 660 x 290 mm

WEIGHT

INDOOR UNIT	Shipping / Net	9.5 kg / 7.5 kg
OUTDOOR UNIT	Shipping / Net	26 kg / 23 kg

DIMENSIONS

unit : mm

improper

INDOOR UNIT

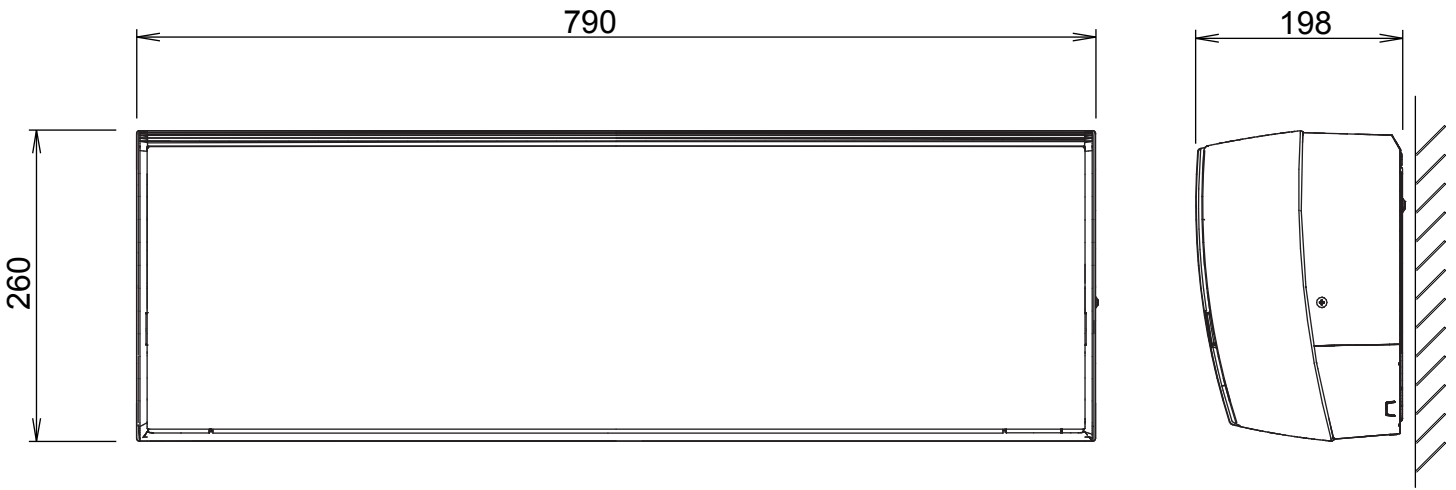

Drain pipe diameter
16.2 mm

Liquid pipe diameter : 6.35 mm
Gas pipe diameter : 9.52 mm

OUTDOOR UNIT

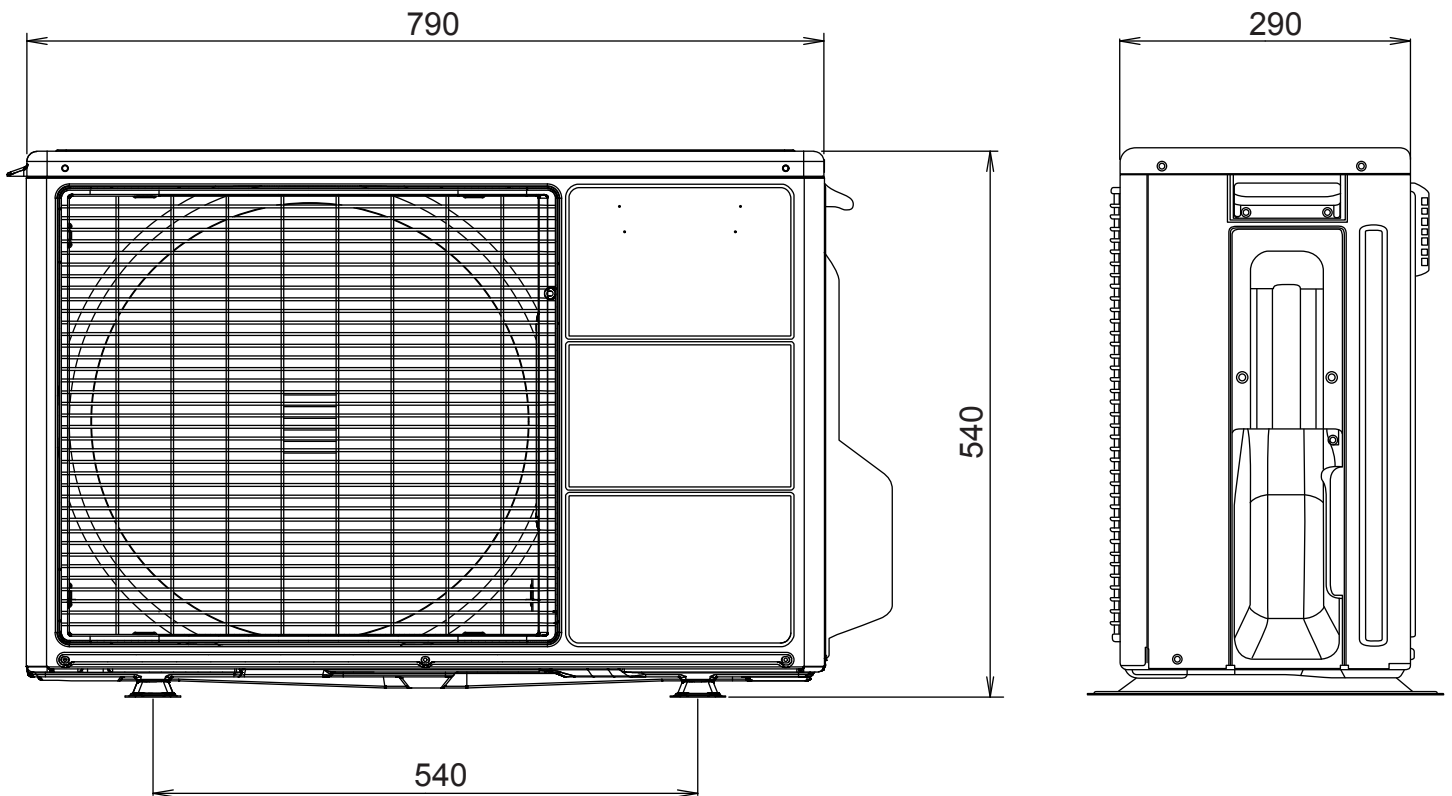

REFRIGERANT SYSTEM DIAGRAM

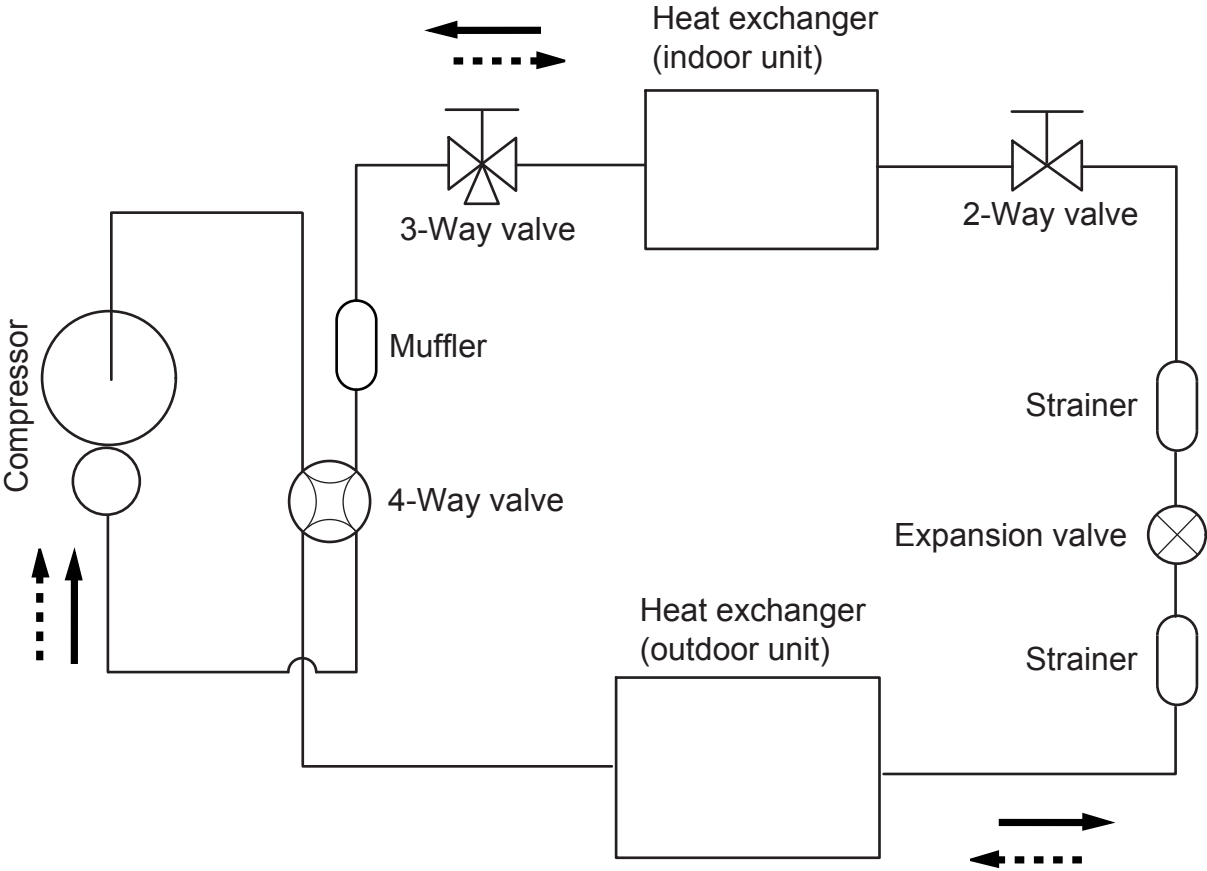

Refrigerant direction

- Cooling
- - - -→ Heating

Refrigerant pipe diameter
Liquid : 1/4" (6.35 mm)
Gas : 3/8" (9.52 mm)

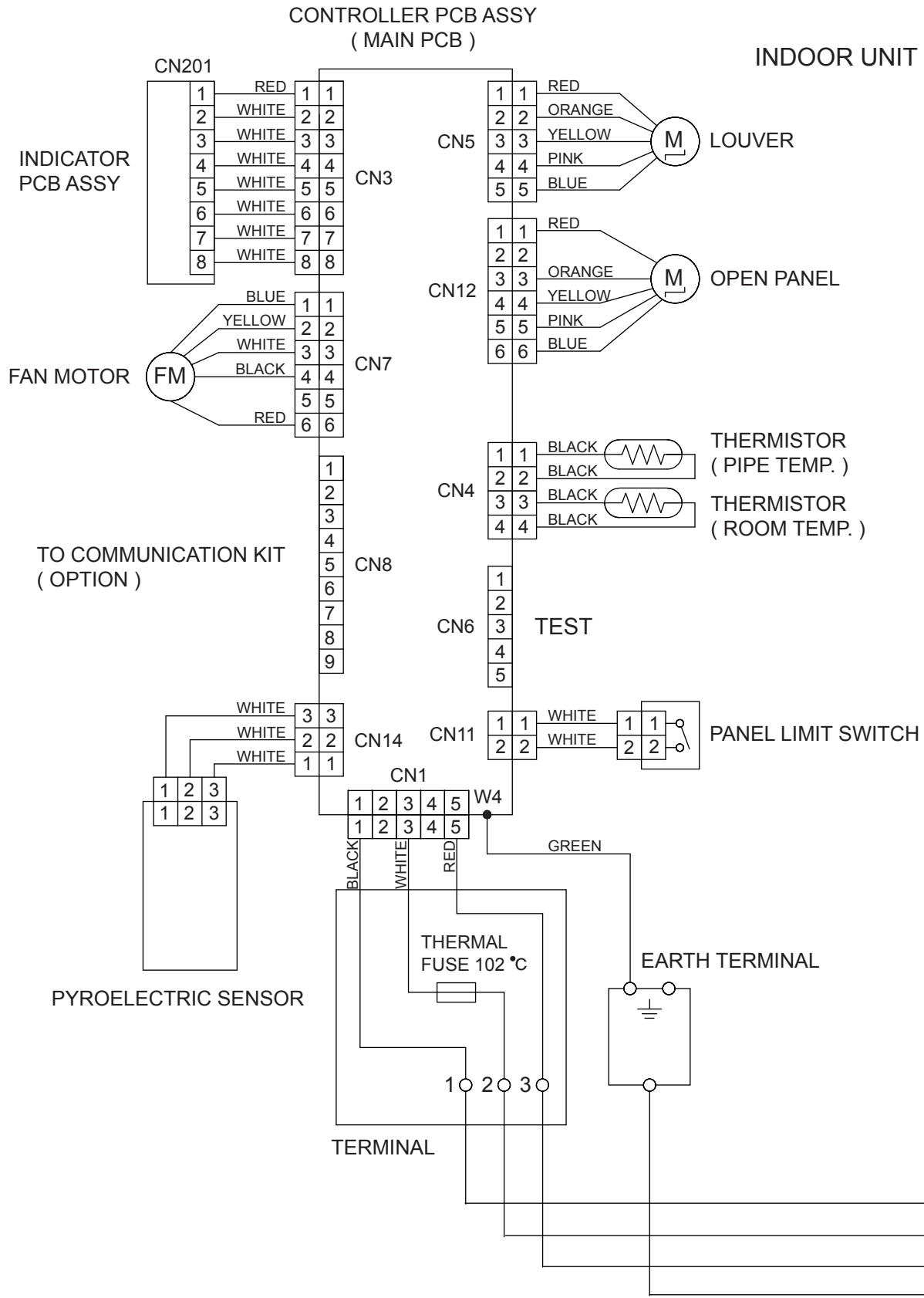

CIRCUIT DIAGRAM

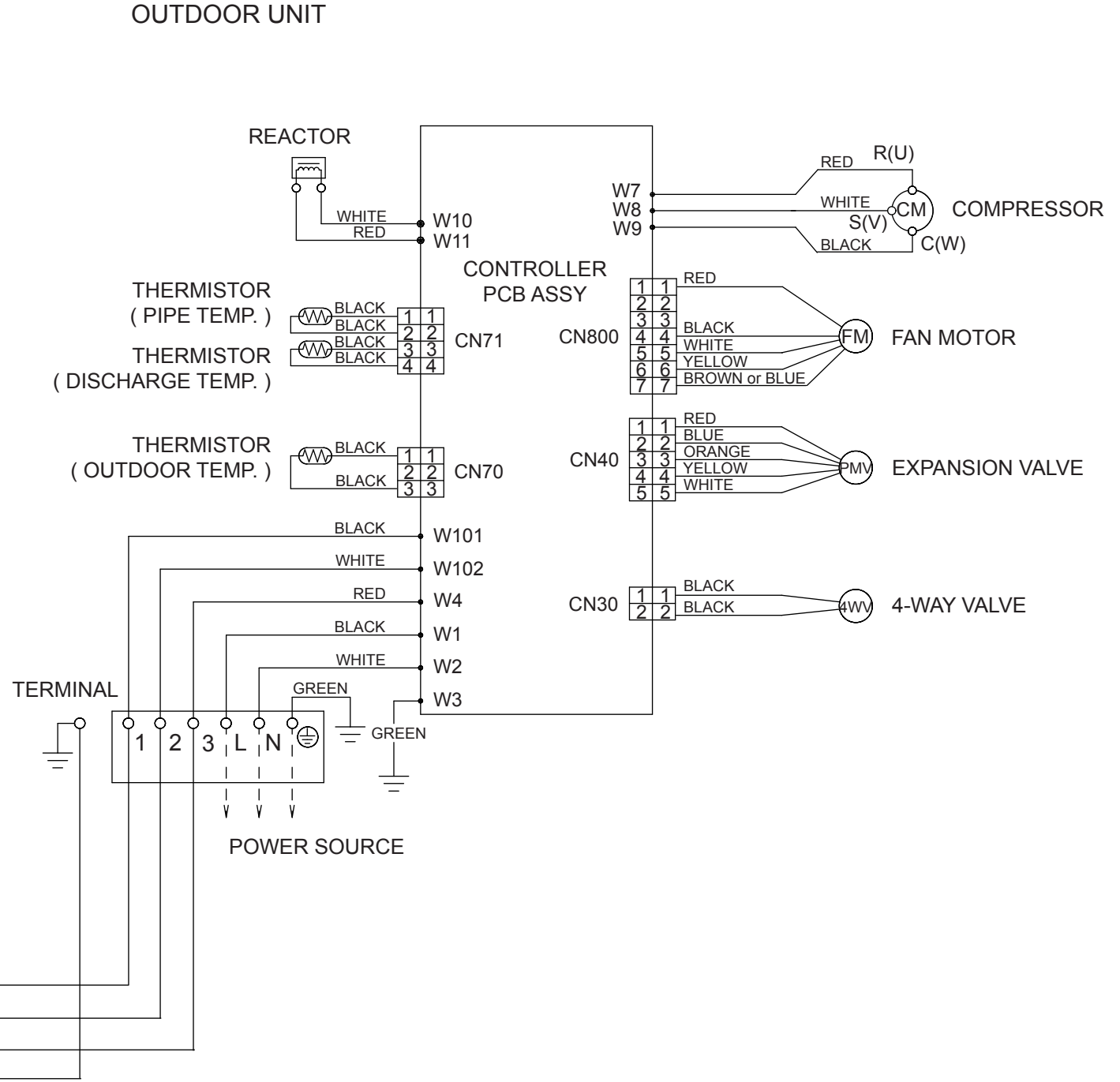

INDOOR PCB CIRCUIT DIAGRAM

CONTROL UNIT
EZ-0100YHSE

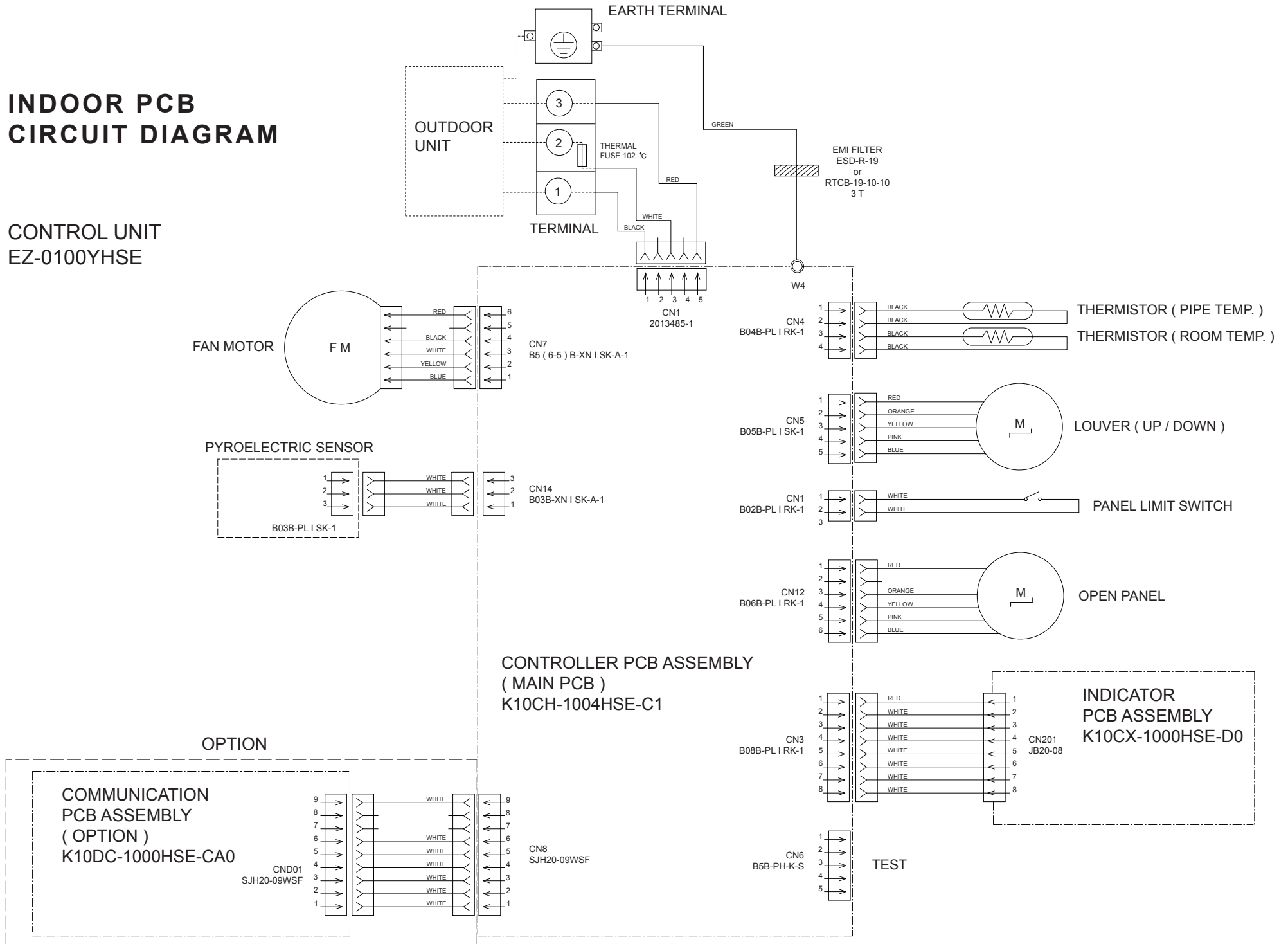

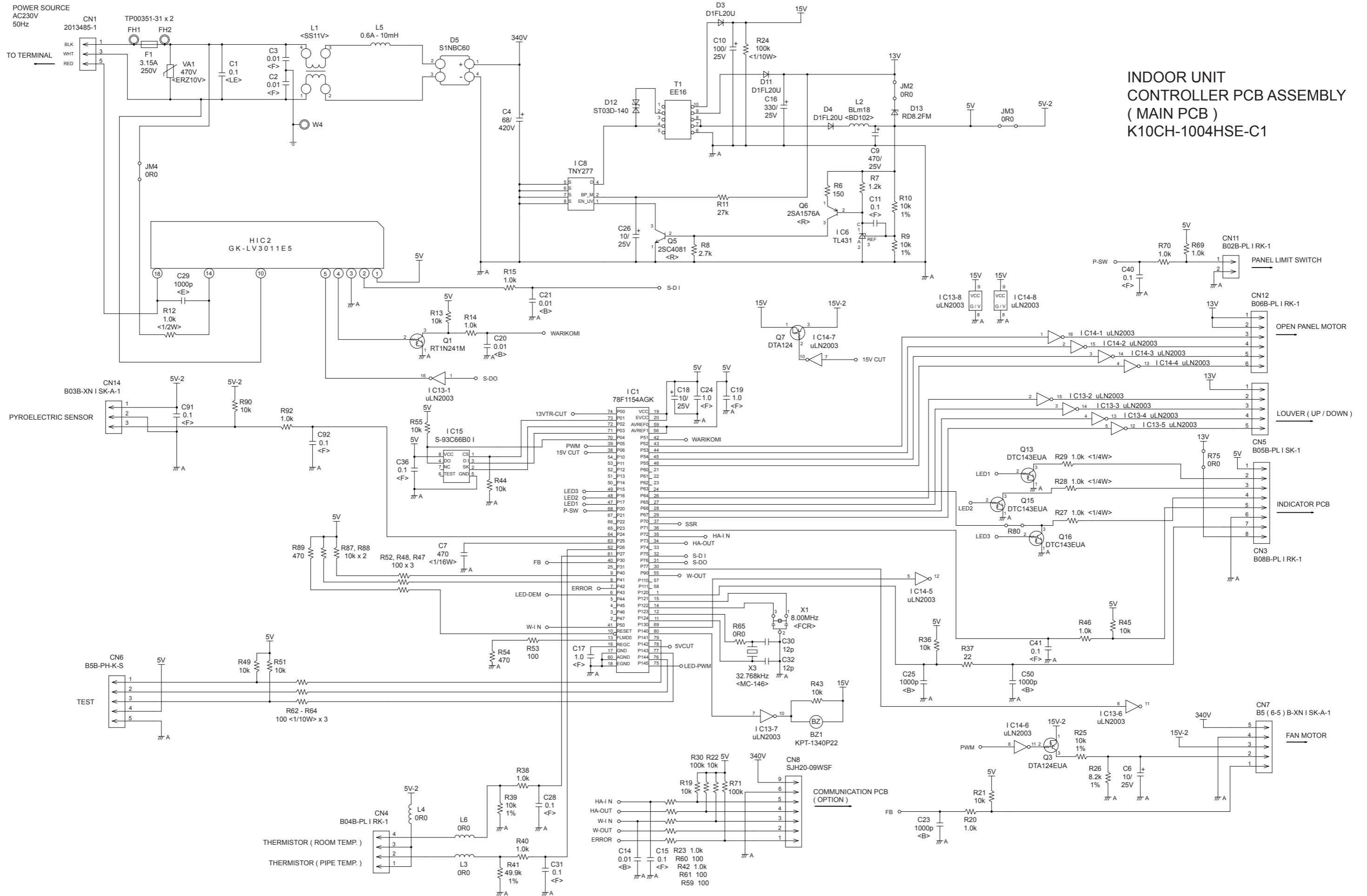

INDOOR UNIT
CONTROLLER PCB ASSEMBLY
(MAIN PCB)
K10CH-1004HSE-C1

INDOOR UNIT
 INDICATOR PCB ASSEMBLY
 K10CX-1000HSE-D0

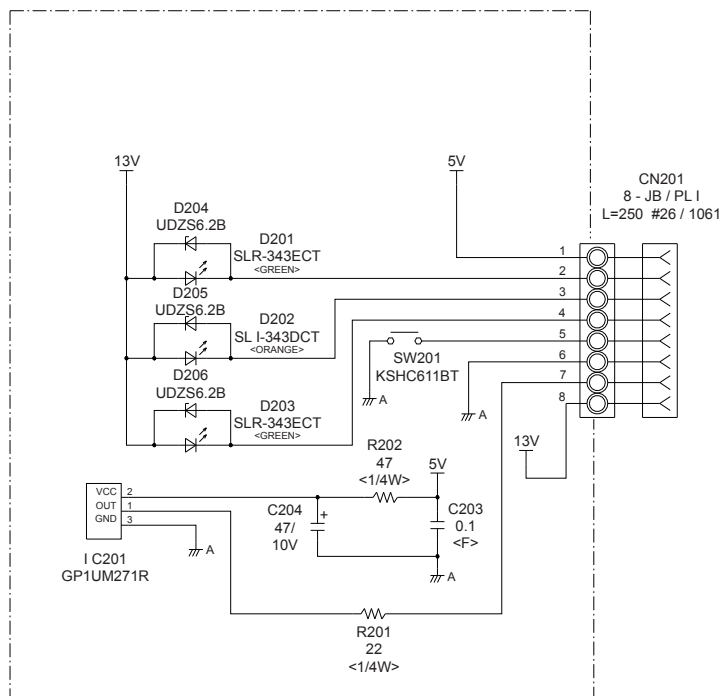

OUTDOOR PCB CIRCUIT DIAGRAM

INVERTER ASSEMBLY EZ-01009HUE

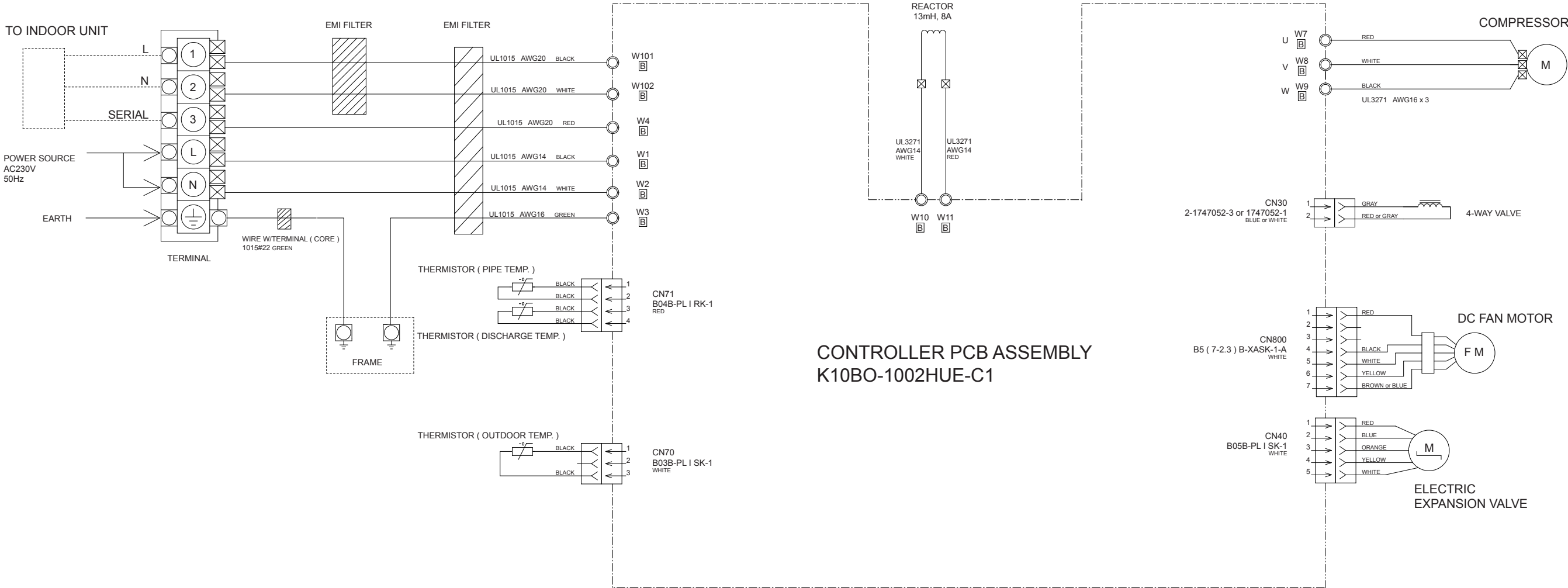

OUTDOOR UNIT
 CONTROLLER PCB ASSEMBLY
 K10BO-1002HUE-C1

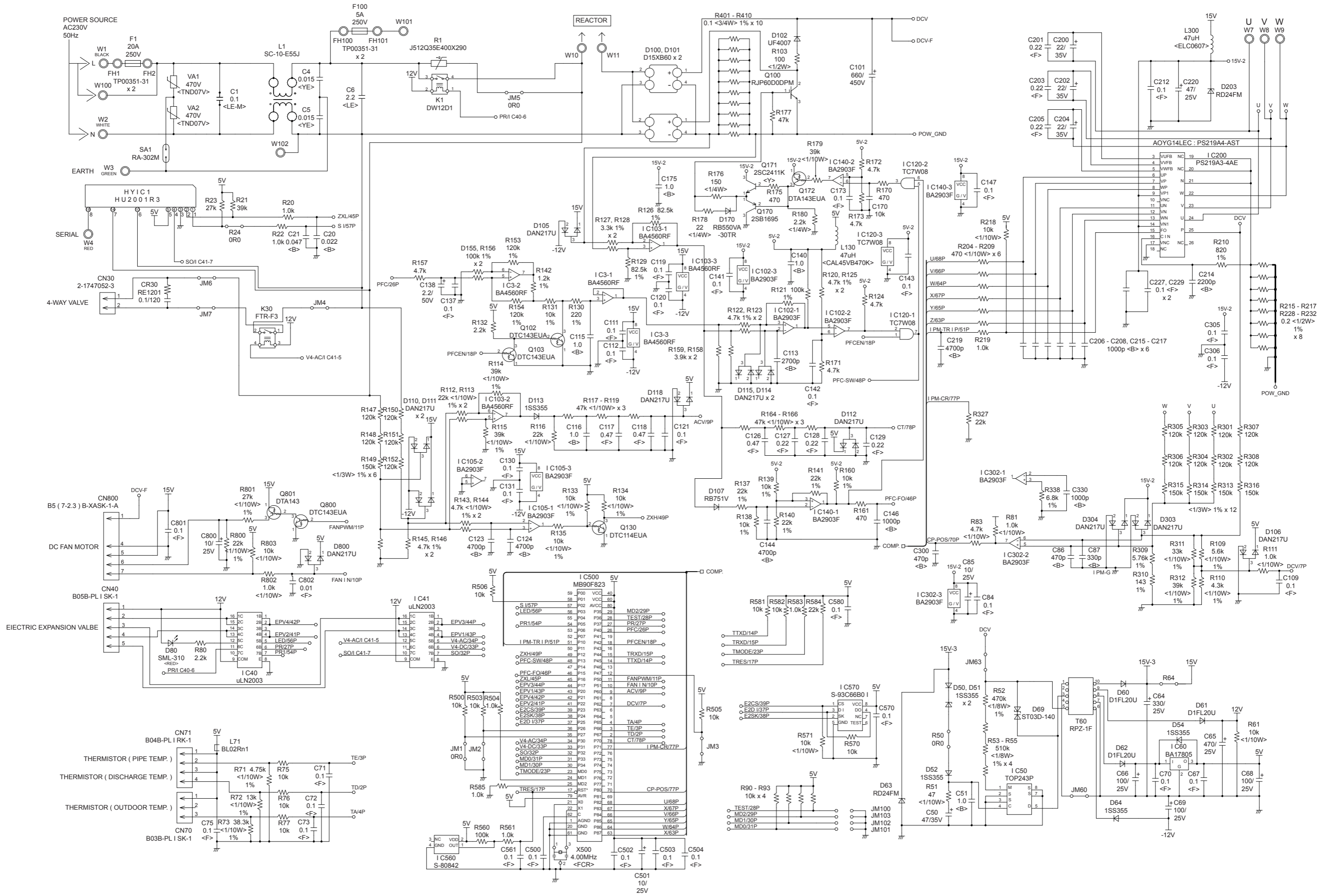

ERROR DETECTION

INDOOR UNIT REMOTE CONTROL

If you use a wireless remote control, the lamp on the photo detector unit will output error codes by way of blinking patterns.

If you use a wired remote control, error codes will appear on the remote control display.

See the lamp blinking patterns and error codes in the table.

An error display is displayed only during operation.

Indoor unit display

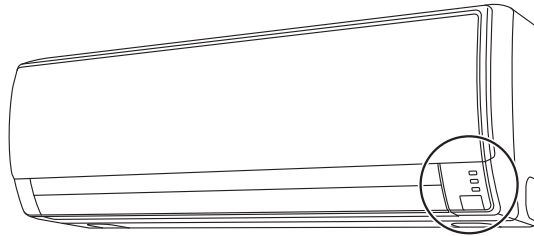

OPERATION OPERATION lamp (green)
TIMER TIMER lamp (orange)
ECONOMY ECONOMY lamp (green)

Wired remote control display (Option)

If an error occurs, the following display will be shown. ("Er" will appear in the set room temperature display.)

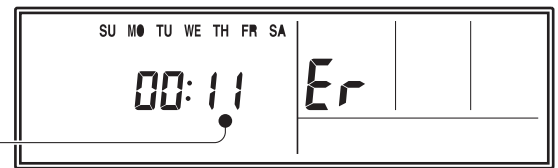

● : 0.5s ON / 0.5s OFF

◇ : 0.1s ON / 0.1s OFF

() : Number of flashing

Error code

Indoor unit			Wired remote control	Description
OPERATION lamp (green)	TIMER lamp (orange)	ECONOMY lamp (green)		
● (1)	● (1)	◇	11	Serial communication error
● (1)	● (2)	◇	12	Wired remote control communication error
● (1)	● (5)	◇	15	Check run unfinished
● (2)	● (2)	◇	22	Indoor unit capacity error
● (2)	● (3)	◇	23	Combination error
● (3)	● (2)	◇	32	Indoor unit PCB model information error
● (3)	● (5)	◇	35	Manual auto switch error
● (4)	● (1)	◇	41	Room temp. sensor error
● (4)	● (2)	◇	42	Indoor unit Heat Ex. Middle temp. sensor error
● (5)	● (1)	◇	51	Indoor unit fan motor error
● (5)	● (3)	◇	53	Drain pump error
● (5)	● (7)	◇	57	Damper error
● (5)	● (15)	◇	5U	Indoor unit error
● (6)	● (2)	◇	62	Outdoor unit main PCB model information error or communication error
● (6)	● (3)	◇	63	Inverter error
● (6)	● (4)	◇	64	Active filter error, PFC circuit error
● (6)	● (5)	◇	65	Trip terminal L error
● (6)	● (10)	◇	6A	Display PCB microcomputers communication error
● (7)	● (1)	◇	71	Discharge temp. sensor error

Indoor unit			Wired remote control	Description
OPERATION lamp (green)	TIMER lamp (orange)	ECONOMY lamp (green)		
● (7)	● (2)	◇	72	Compressor temp. sensor error
● (7)	● (3)	◇	73	Outdoor unit Heat Ex. liquid temp. sensor error
● (7)	● (4)	◇	74	Outdoor temp. sensor error
● (7)	● (5)	◇	75	Suction Gas temp. sensor error
● (7)	● (6)	◇	76	• 2-way valve temp. sensor error • 3-way valve temp. sensor error
● (7)	● (7)	◇	77	Heat sink temp. sensor error
● (8)	● (2)	◇	82	• Sub-cool Heat Ex. gas inlet temp. sensor error • Sub-cool Heat Ex. gas outlet temp. sensor error
● (8)	● (3)	◇	83	Liquid pipe temp. sensor error
● (8)	● (4)	◇	84	Current sensor error
● (8)	● (6)	◇	86	• Discharge pressure sensor error • Suction pressure sensor error • High pressure switch error
● (9)	● (4)	◇	94	Trip detection
● (9)	● (5)	◇	95	Compressor rotor position detection error (permanent stop)
● (9)	● (7)	◇	97	Outdoor unit fan motor error
● (9)	● (9)	◇	99	4-way valve error
● (10)	● (1)	◇	A1	Discharge temp. error
● (10)	● (3)	◇	A3	Compressor temp. error
● (10)	● (4)	◇	A4	High pressure error
● (10)	● (5)	◇	A5	Low pressure error

OUTDOOR UNIT

LED	ERROR
on	Discharge temperature abnormal
0.5 second on / 0.5 second off	IPM overcurrent protection
0.1 second on / 0.1 second off	Thermistor abnormal
2.0 second on / 2.0 second off	CT abnormal
0.1 second on / 2.0 second off	Compressor location abnormal
5.0 second on / 5.0 second off	Fan abnormal

PARTS

INDOOR UNIT

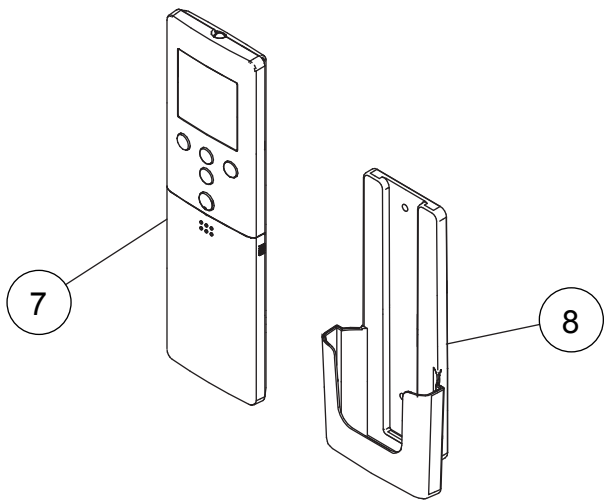
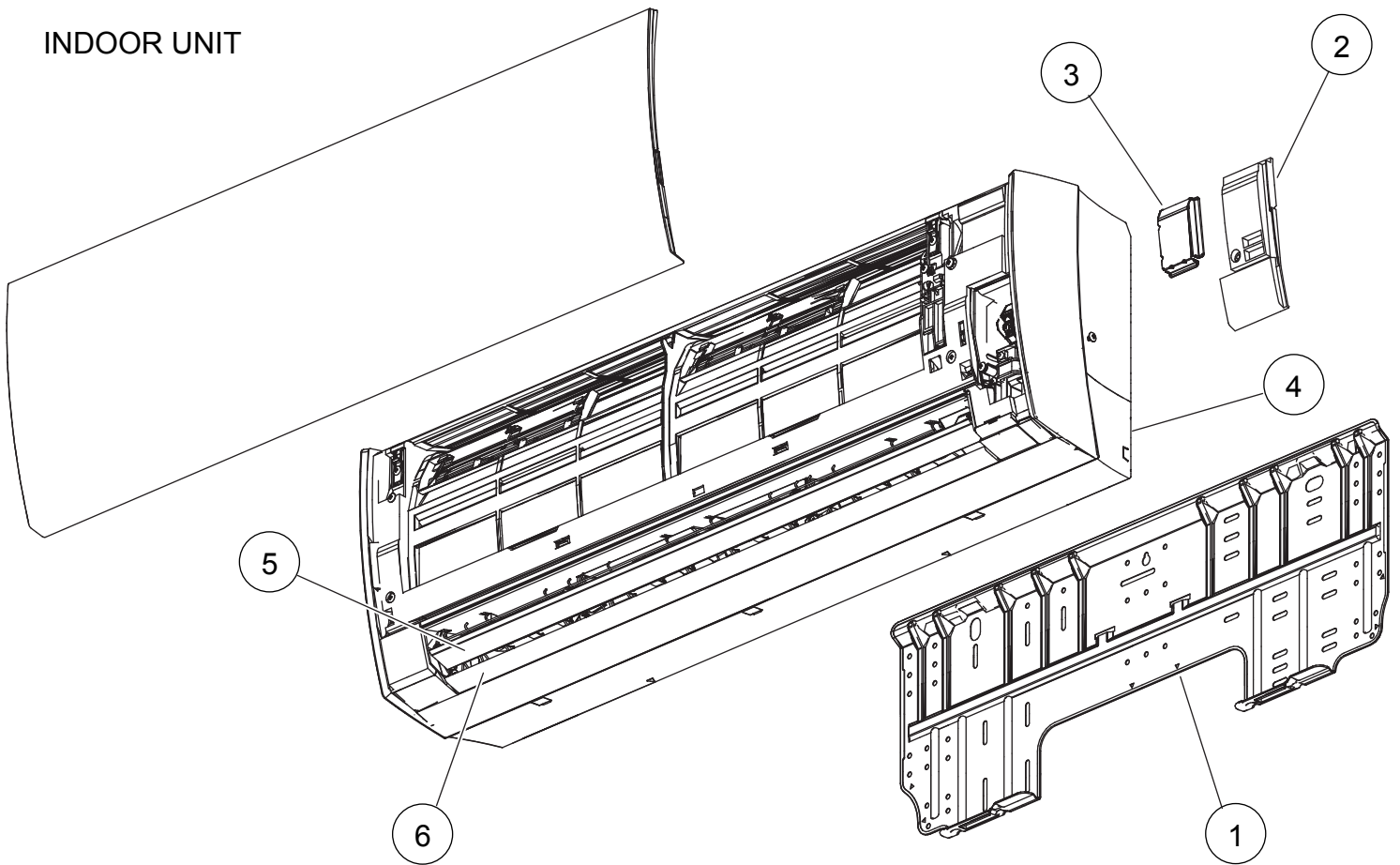

Ref.	Description	Part number
1	Bracket Panel	9318913002
2	Wire Cover	9318911008
3	Wire Shield	9318919004
4	Under Cover	9318879001
5	Louver U	9318880007
6	Louver Z	9318881004
7	Remote Control	9319207001
8	Remote Control Holder	9318912005
--	Air Clean Filter Assy	9317250009

INDOOR UNIT
Front panel

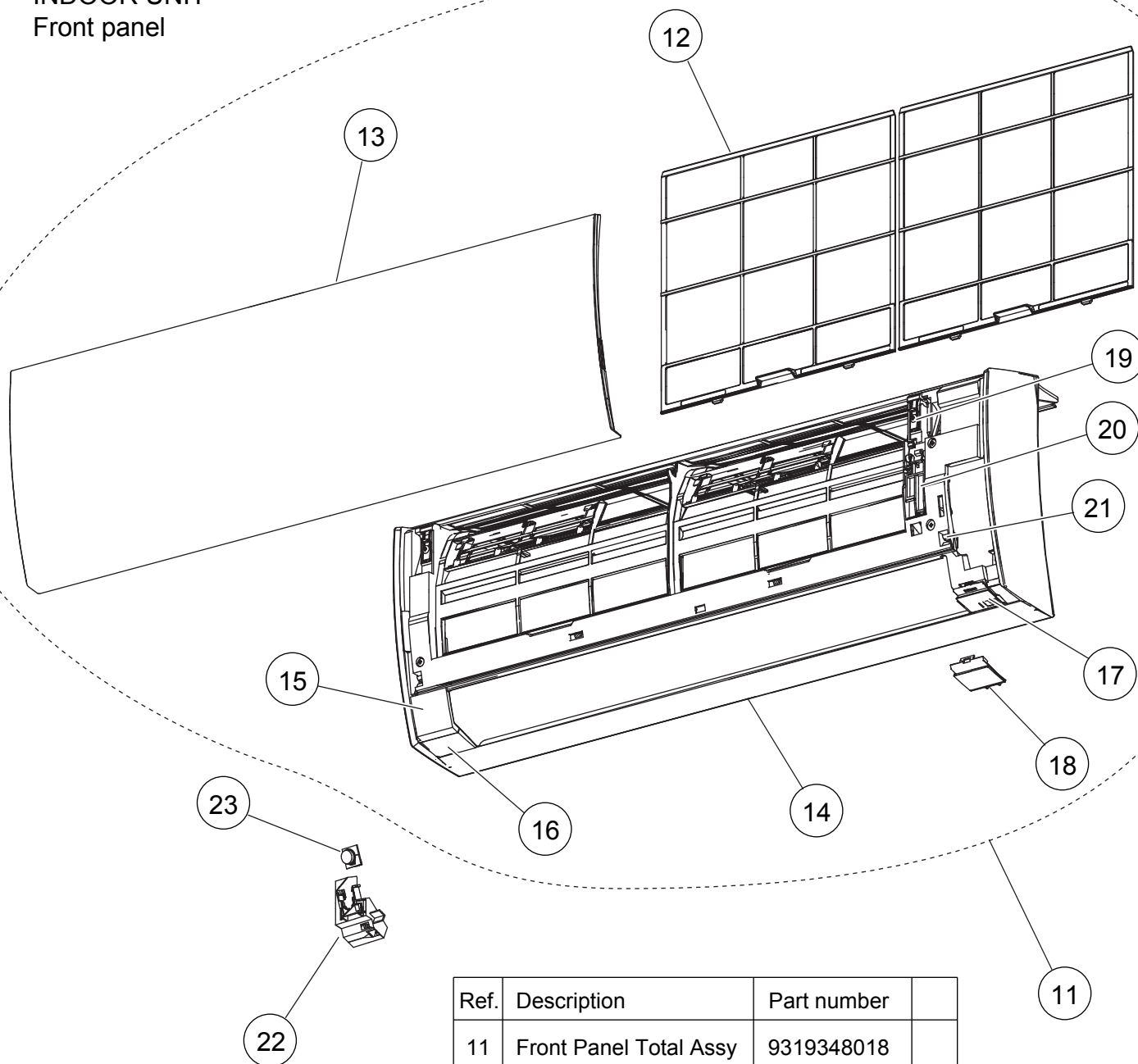

Ref.	Description	Part number
11	Front Panel Total Assy	9319348018
12	Air Filter	9318883008
13	Intake Grille Assy	9319351018
14	Front Panel	9318876000
15	Front Panel Cover T	9318909005
16	Display Plate Holder L	9318894004
17	Display Plate Holder R	9318895001
18	Display Plate R	9318893007
19	Arm Cover	9318900002
20	Grille Stay	9318899009
21	Grille Clamper B	9316951006
22	Motion LED Display Case	9318907001
23	Pyroelectric Sensor	9317755023

INDOOR UNIT
Evaporator

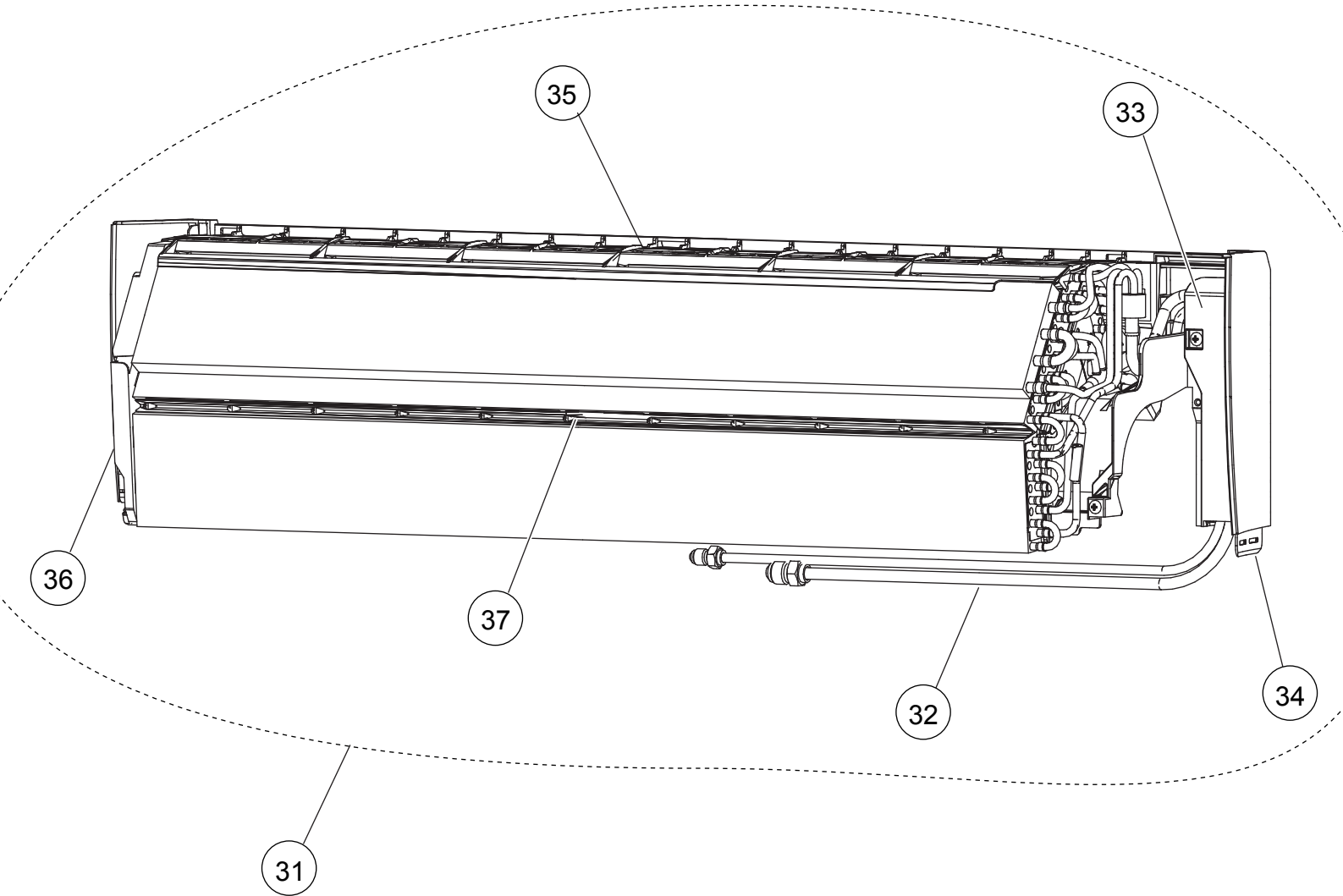

Ref.	Description	Part number
31	Evaporator Total Assy	9319327006
32	Joint Pipe Assy	9319322001
33	Joint Pipe Holder	9318901009
34	Base	9318874006
35	Filter Guide	9318887006
36	Evaporator Holder L	9318875003
37	Air Seal	9319295008

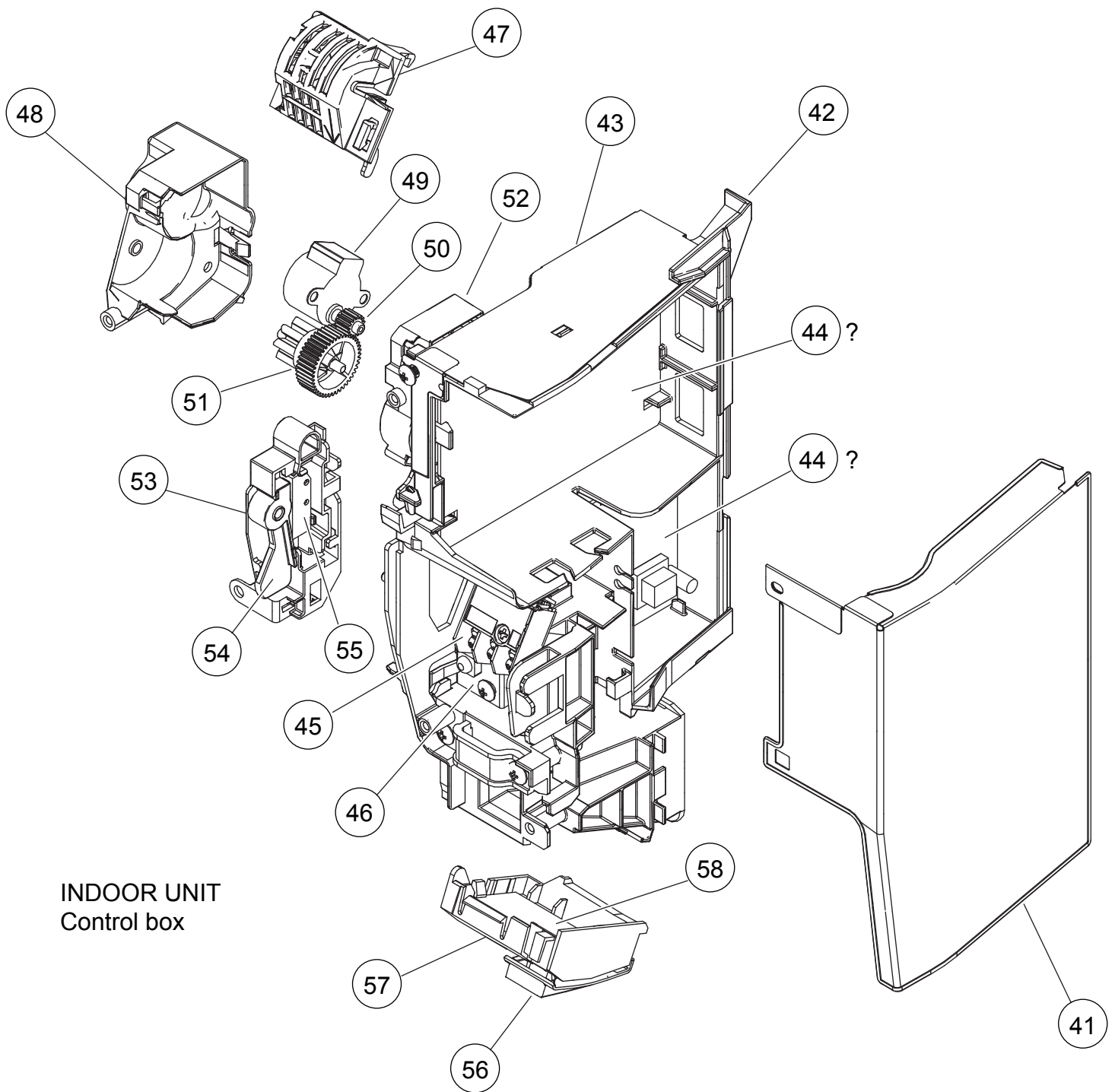

INDOOR UNIT
Control box

Ref.	Description	Part number
41	Cover Shield A	9318916003
42	Control Box	9318882001
43	Box Shield Assy	9319344003
44	Controller PCB Assy	9708713052
45	Terminal	9900638009
46	Earth Terminal	9318918007
47	Room Thermistor Holder	9319068008
48	Gear Cover	9318902006
49	Step Motor	9900384166
50	Gear B	9319294001

Ref.	Description	Part number
51	Panel Gear	9319293004
52	Gear Case	9318903003
53	Switch Case	9319332000
54	Grille Key Top	9319334004
55	Micro Switch	9900625009
56	Receiver Window	9318891003
57	Display Case	9318906004
58	Display PCB Assy	9708824017
--	Thermistor Assy	9900627003

INDOOR UNIT
Casing assy

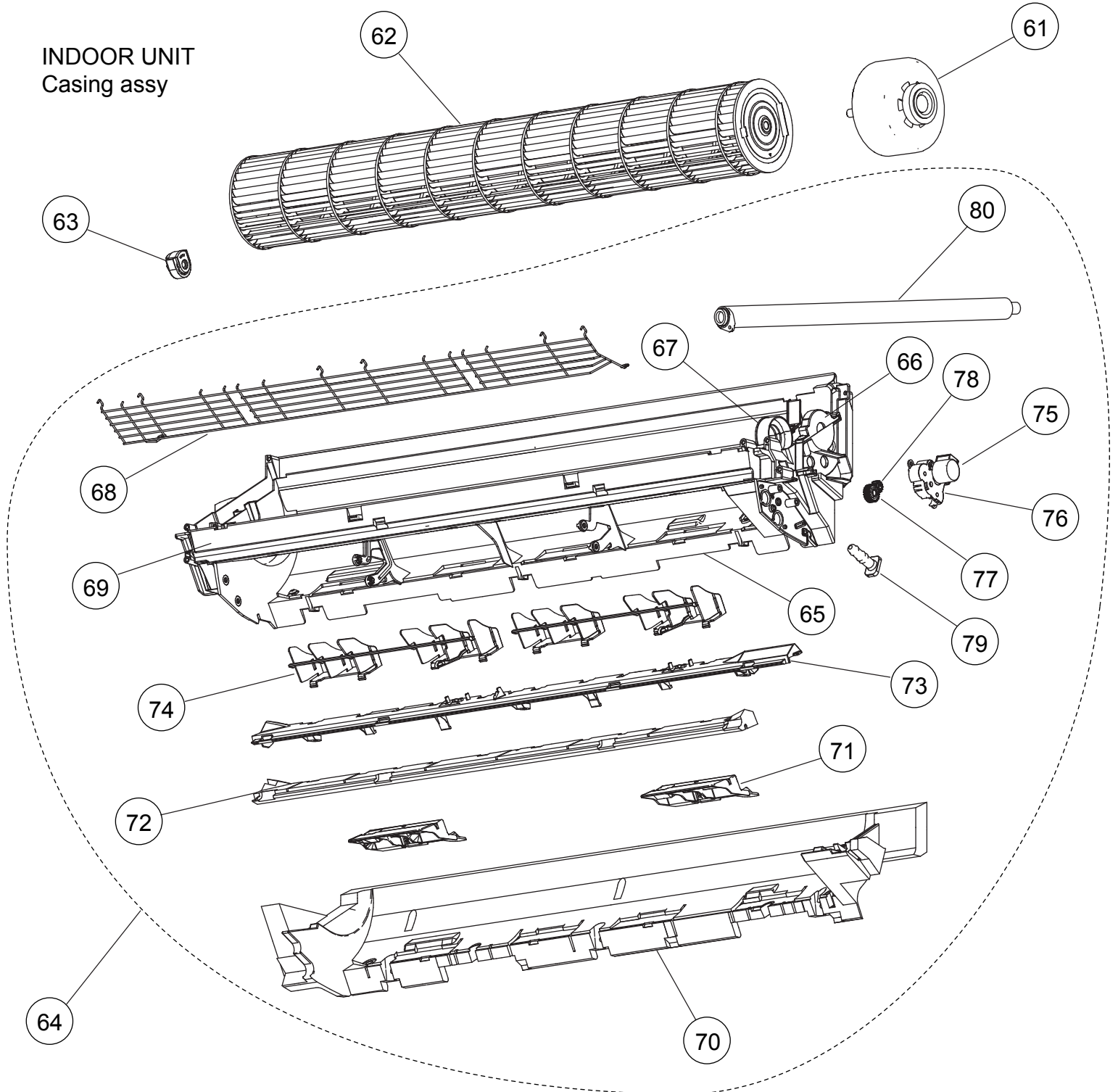

Ref.	Description	Part number
61	Fan Motor	9602947003
62	Crossflow Fan Assy	9319361000
63	Bearing C Assy	9306628017
64	Casing Assy	9319342009
65	Casing	9318873009
66	Motor Cover	9316601000
67	Motor Cover	9318888003
68	Fan Guard	9318924008
69	Casing Cover F	9318923001
70	Casing Cover B	9318920000

Ref.	Description	Part number
71	Pipe Bracket	9318889000
72	Panel Cover	9319296005
73	Louver Holder	9318886009
74	R and L Louver B	9318885002
75	Motor Step	9900384128
76	Louver Gear Holder	9318905007
77	Louver Gear	9318904000
78	Gear A	9309994003
79	Drain Cap	9316177017
80	Drain Hose Assy	9316904002

PARTS

OUTDOOR UNIT

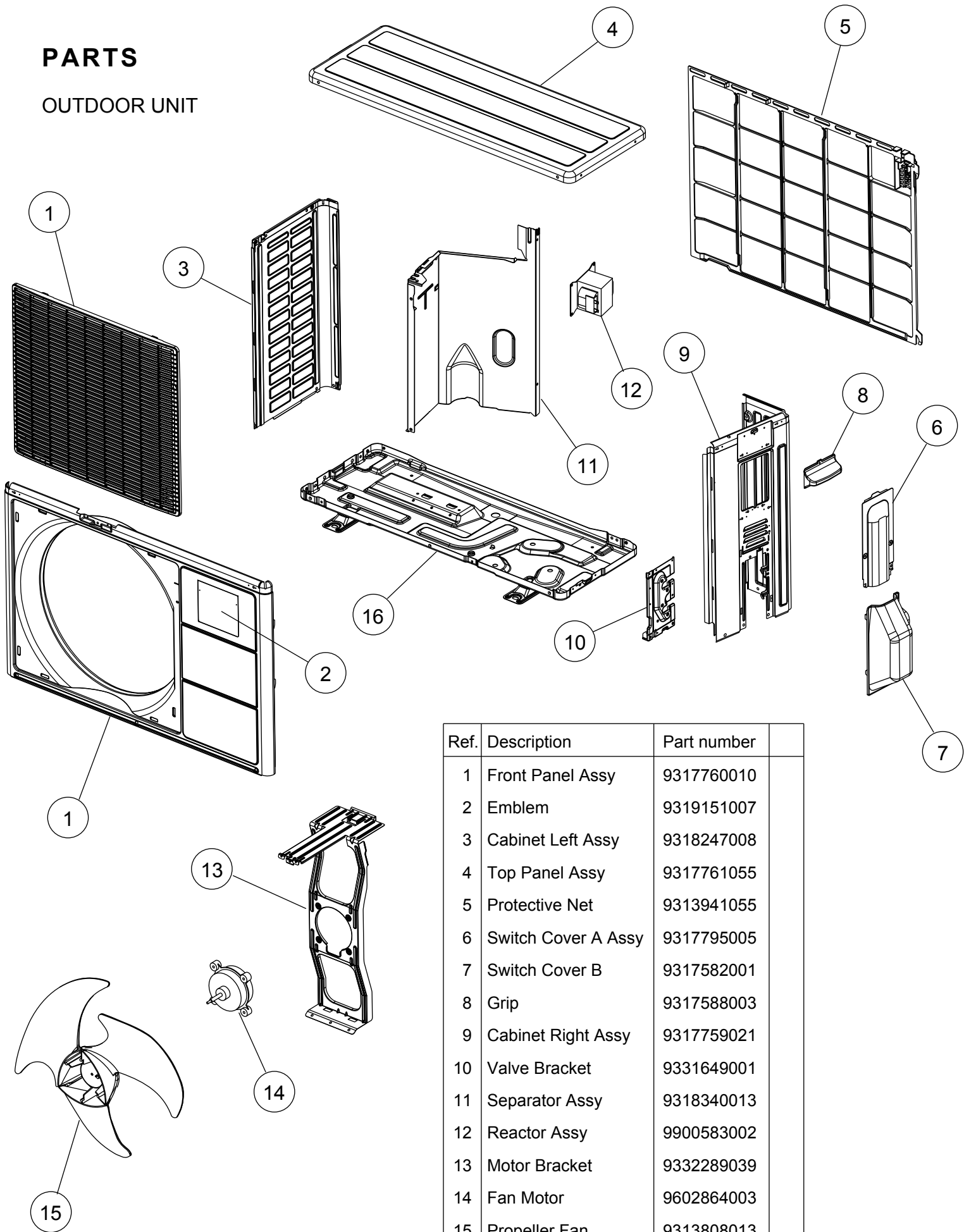

Ref.	Description	Part number
1	Front Panel Assy	9317760010
2	Emblem	9319151007
3	Cabinet Left Assy	9318247008
4	Top Panel Assy	9317761055
5	Protective Net	9313941055
6	Switch Cover A Assy	9317795005
7	Switch Cover B	9317582001
8	Grip	9317588003
9	Cabinet Right Assy	9317759021
10	Valve Bracket	9331649001
11	Separator Assy	9318340013
12	Reactor Assy	9900583002
13	Motor Bracket	9332289039
14	Fan Motor	9602864003
15	Propeller Fan	9313808013
16	Base Assy	9316885066
--	Drain Assy	9303029022

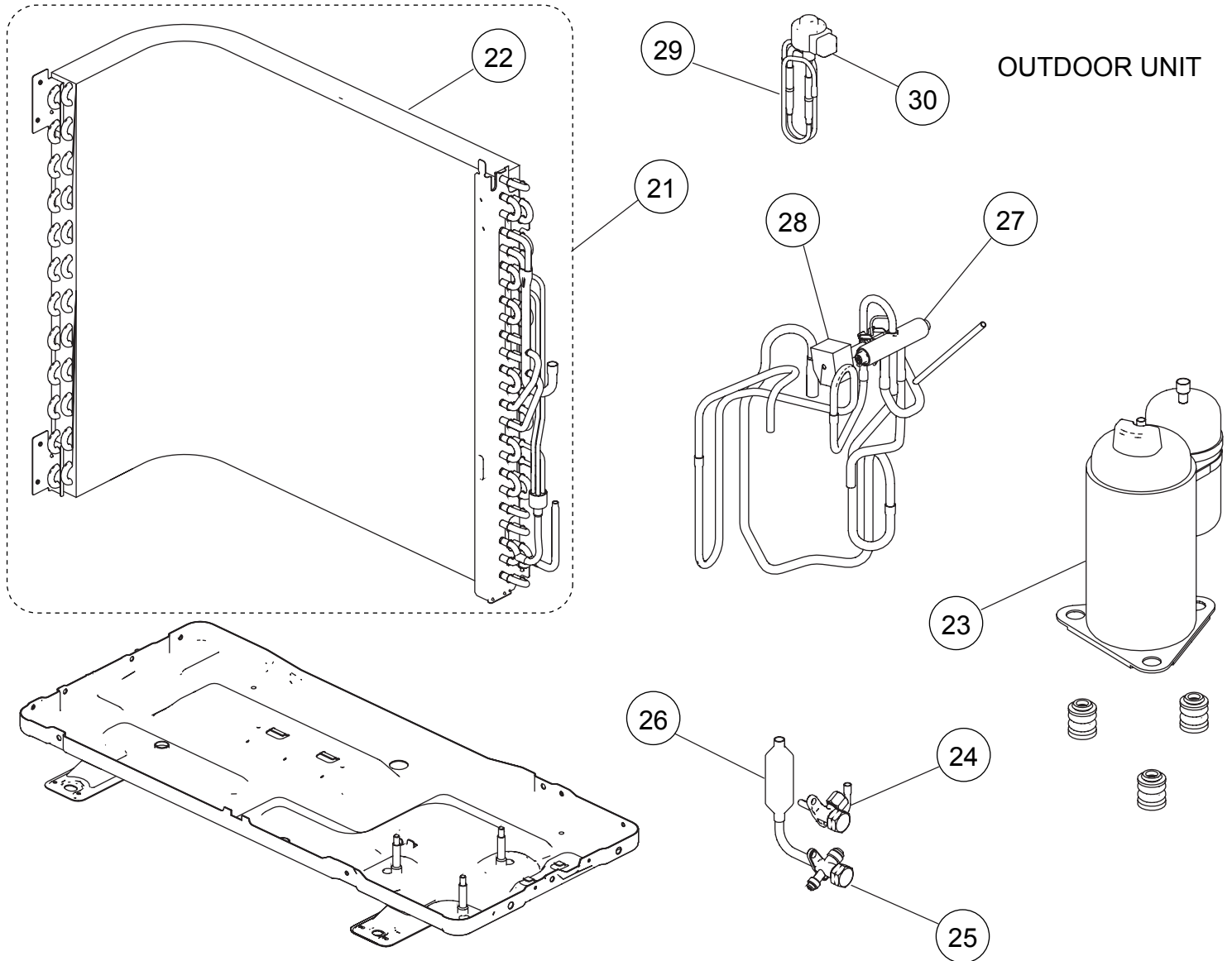

Ref.	Description	Part number
21	Condenser Total Assy	9332359008
22	Condenser Assy	9332360004
23	Compressor Assy	9317619004
24	2 way Valve Assy	9332371000
25	3 way Valve Assy	9315574015
26	Muffler	9308625007
27	4 way Valve Assy	9332365009
28	Solenoid	9970110023
29	Pulse Motor Valve Assy	9332368000
30	Expansion Valve Coil	9970095030

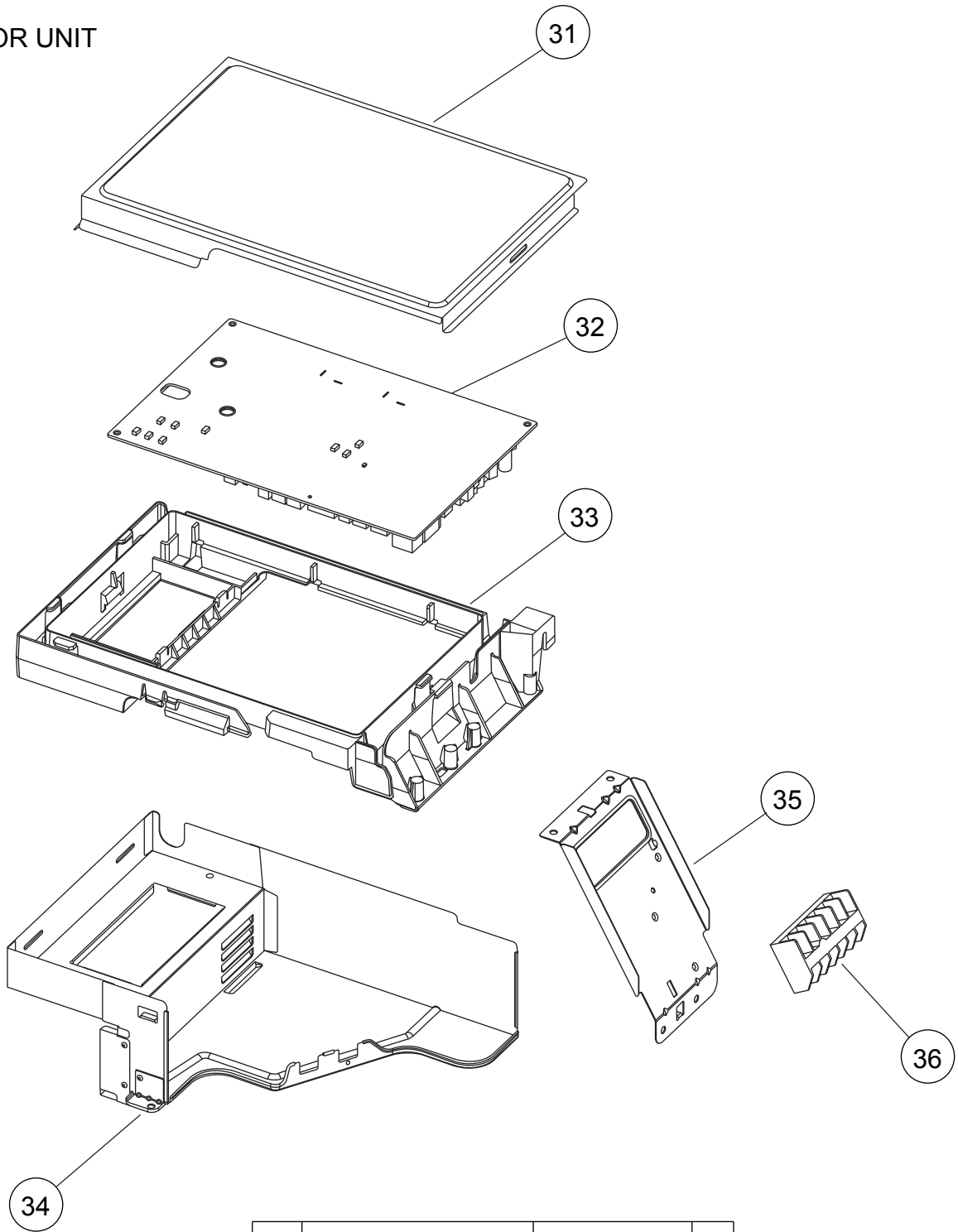

OUTDOOR UNIT



Ref.	Description	Part number
31	Sealed Panel	9318181005
32	Controller PCB Assy	9708683034
33	PCB Holder	9318182002
34	Inverter Case Assy	9318242003
35	Terminal Bracket	9317603010
36	Terminal 3P	9900016067
--	Outdoor Thermistor	9900565008
--	Thermistor Assy	9900614010

ACCESSORIES

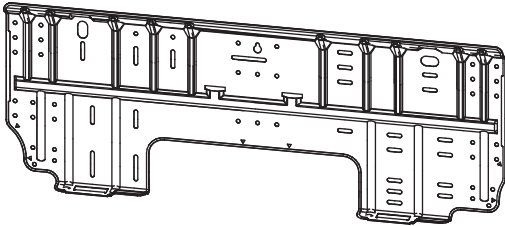
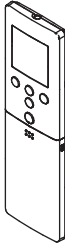
INDOOR UNIT

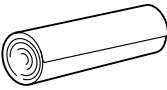
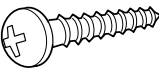
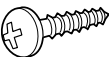
Name and Shape	Part number
<p>Bracket panel</p> 	<p>9318913002</p>
<p>Remote control</p> 	<p>9319207001</p>
<p>Remote control holder</p> 	<p>9318912005</p>
<p>Battery (penlight)</p> 	<p>0600185541</p>
<p>Cloth tape</p> 	<p>9310519004</p>
<p>Tapping screw (big) (ϕ 4 x 25)</p> 	<p>0700076046</p>
<p>Tapping screw (small) (ϕ 3 x 12)</p> 	<p>0700019036</p>

OPTION

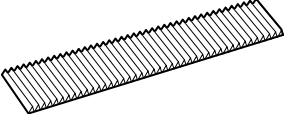
Name and Shape	Part number
<p>Air cleaning filter</p> 	<p>UTR-FA16 UTR-FA16-2</p>

1103G3923