

AIR CONDITIONER

Wall mounted type

DESIGN & TECHNICAL MANUAL

INDOOR



ASYG07KETE
ASYG09KETE
ASYG12KETE
ASYG14KETE

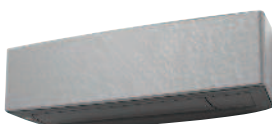

ASYG07KETE-B
ASYG09KETE-B
ASYG12KETE-B
ASYG14KETE-B

OUTDOOR



AOYG07KETA
AOYG09KETA
AOYG12KETA

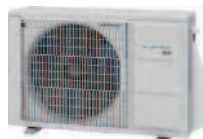

AOYG14KETA

FUJITSU GENERAL LIMITED

Notices:

- Product specifications and design are subject to change without notice for future improvement.
- For further details, please check with our authorized dealer.

Trademarks

FGLair™ is trademark of Fujitsu General Limited in the United States, other countries or both.

Google Play™ is trademark of Google Inc.

App Store® is a service mark of Apple Inc., registered in the U.S. and other countries.

CONTENTS

Part 1. INDOOR UNIT	1
1. Specifications	2
2. Dimensions	4
2-1. Models: ASYG07KETE, ASYG09KETE, ASYG12KETE, ASYG14KETE, ASYG07KETE-B, ASYG09KETE-B, ASYG12KETE-B, and ASYG14KETE-B.....	4
3. Wiring diagrams	6
3-1. Models: ASYG07KETE, ASYG09KETE, ASYG12KETE, ASYG14KETE, ASYG07KETE-B, ASYG09KETE-B, ASYG12KETE-B, and ASYG14KETE-B.....	6
4. Capacity table	7
4-1. Cooling capacity.....	7
4-2. Heating capacity.....	9
5. Fan performance	10
5-1. Air velocity distributions.....	10
5-2. Airflow.....	12
6. Operation noise (sound pressure)	16
6-1. Noise level curve.....	16
6-2. Sound level check point.....	18
7. Safety devices	19
8. External input and output	20
8-1. External input.....	21
8-2. External output.....	23
8-3. Combination of external input and output.....	25
8-4. Details of function.....	27
9. Group connection	33
10. Remote controller	34
10-1. Wireless remote controller.....	34
11. Function settings	36
11-1. Function settings by using remote controller.....	36
11-2. Custom code setting for wireless remote controller.....	43
12. Accessories	44
12-1. Models: ASYG07KETE, ASYG09KETE, ASYG12KETE, ASYG14KETE, ASYG07KETE-B, ASYG09KETE-B, ASYG12KETE-B, and ASYG14KETE-B.....	44
13. Optional parts	45
13-1. Controllers.....	45
13-2. Others.....	46

CONTENTS (continued)

Part 2. OUTDOOR UNIT	47
1. Specifications	48
2. Dimensions	49
2-1. Models: AOYG07KETA, AOYG09KETA, and AOYG12KETA	49
2-2. Model: AOYG14KETA	50
3. Installation space	51
3-1. Models: AOYG07KETA, AOYG09KETA, AOYG12KETA, and AOYG14KETA	51
4. Refrigerant circuit	54
4-1. Models: AOYG07KETA, AOYG09KETA, and AOYG12KETA	54
4-2. Model: AOYG14KETA	55
5. Wiring diagrams	56
5-1. Models: AOYG07KETA, AOYG09KETA, AOYG12KETA, and AOYG14KETA	56
6. Capacity compensation rate for pipe length and height difference	57
6-1. Models: AOYG07KETA and AOYG09KETA	57
6-2. Model: AOYG12KETA	58
6-3. Model: AOYG14KETA	58
7. Additional charge calculation	59
7-1. Models: AOYG07KETA and AOYG09KETA	59
7-2. Model: AOYG12KETA	59
7-3. Model: AOYG14KETA	59
8. Airflow	60
8-1. Model: AOYG07KETA	60
8-2. Model: AOYG09KETA	60
8-3. Model: AOYG12KETA	60
8-4. Model: AOYG14KETA	61
9. Operation noise (sound pressure)	62
9-1. Noise level curve	62
9-2. Sound level check point	64
10. Electrical characteristics	65
11. Safety devices	66
12. Accessories	67
12-1. Models: AOYG07KETA, AOYG09KETA, AOYG12KETA, and AOYG14KETA	67

Part 1. INDOOR UNIT

WALL MOUNTED TYPE:

ASYG07KETE

ASYG09KETE

ASYG12KETE

ASYG14KETE

ASYG07KETE-B

ASYG09KETE-B

ASYG12KETE-B

ASYG14KETE-B

1. Specifications

Type			Wall mounted					
			Inverter heat pump					
Model name			ASYG07KETE ASYG07KETE-B	ASYG09KETE ASYG09KETE-B	ASYG12KETE ASYG12KETE-B	ASYG14KETE ASYG14KETE-B		
Power supply			230 V ~ 50 Hz					
Available voltage range			198—264 V					
Capacity	Cooling	Rated	kW	2.00	2.50	3.40	4.20	
		Min.—Max.	Btu/h	6,800	8,500	11,600	14,300	
			kW	0.9—3.0	0.9—3.2	0.9—3.9	0.9—4.4	
	Heating	Rated	Btu/h	3,100—10,200	3,100—10,900	3,100—13,300	3,100—15,000	
			kW	2.50	2.80	4.00	5.40	
		Min.—Max.	Btu/h	8,500	9,500	13,600	18,400	
Input power	Cooling	Rated	kW	0.450	0.630	0.935	1.220	
				0.25—1.17	0.25—1.21	0.25—1.27	0.25—1.40	
		Min.—Max.	0.555	0.620	0.960	1.410		
	Heating	Rated	kW	0.25—1.21	0.25—1.26	0.25—1.52	0.25—1.73	
				0.555	0.620	0.960	1.410	
		Min.—Max.	0.25—1.21	0.25—1.26	0.25—1.52	0.25—1.73		
Fan	HIGH	W	22.1	26.5	26.5	33.6		
			15.1	16.0	16.0	20.0		
			10.0	10.0	10.0	11.8		
			6.4	6.4	6.4	7.1		
Current	Cooling	Rated	A	2.6	3.4	4.8	5.8	
	Heating			3.0	3.4	5.1	6.8	
EER	Cooling	kW/kW		4.43	3.97	3.65	3.44	
COP	Heating	kW/kW		4.52	4.52	4.17	3.83	
Sensible capacity	Cooling	kW		1.2	1.6	2.2	3.2	
Power factor	Cooling	%		75	81	88	88	
	Heating	%		80	79	87	87	
Moisture removal			L/h (pints/h)	1.0 (1.80)	1.3 (2.30)	1.8 (3.20)	2.1 (3.70)	
Maximum operating current *1	Cooling	A		6.5	6.5	6.5	6.5	
	Heating	A		9.0	9.0	9.0	9.0	
Fan	Airflow rate	Cooling	m ³ /h	HIGH	650	700	700	770
				MED	540	560	560	600
				LOW	430	430	430	450
				QUIET	270	270	270	280
		Heating	m ³ /h	HIGH	720	750	770	800
				MED	580	610	640	660
				LOW	460	470	520	520
				QUIET	330	330	330	340
	Type × Q'ty	W		Cross flow fan × 1				
	Motor output	W		22	24	27	30	
Sound pressure level *2	Cooling	dB (A)	HIGH	38	40	40	43	
			MED	33	34	35	36	
			LOW	29	29	30	30	
			QUIET	20	20	20	20	
	Heating	dB (A)	HIGH	41	42	42	44	
			MED	35	36	38	39	
			LOW	31	31	33	33	
			QUIET	22	22	22	24	
Heat exchanger type	Dimensions (H × W × D)		mm	Main1: 210 × 670 × 26.6 Main2: 112 × 670 × 20			Main1: 210 × 670 × 26.6 Main2: 112 × 670 × 20 Sub: 84 × 670 × 13.3	
	Fin pitch			Main1: 1.2, Main2: 1.1			Main1: 1.2, Main2: 1.1, Sub: 1.4	
	Rows × Stages			Main1: 2 × 10, Main2: 2 × 7			Main1: 2 × 10, Main2: 2 × 7, Sub: 1 × 4	
	Pipe type			Copper tube				
Enclosure	Material		Aluminum					
	Material		Polystyrene					
	Color		KETE; White + Pearl white (painted) Approximate color of Munsell N 9.25/ KETE-B; Dark Gray + Silver (painted) Approximate color of Munsell 0.5P 3.5/0.2					
Dimensions (H × W × D)	Net	mm	295 × 950 × 230					
	Gross		284 × 1,027 × 357					
Weight	Net	kg	11.0					
	Gross		14.5					
Connection pipe	Size	Liquid	mm (in)	Ø 6.35 (Ø 1/4)				
		Gas		Ø 9.52 (Ø 3/8)				
Drain hose	Method		Flare					
	Material		PP+HDPE					
Operation range	Tip diameter		mm	Ø 13.8 (I.D.), Ø 15.0 to Ø 16.8 (O.D.)				
	Cooling	°C		18 to 32				
Remote controller type	Heating	°C	80 or less					
			16 to 30					
Remote controller type			Wireless (Wired, Mobile app)*3 [FGLair™] [option]					

Type	Wall mounted			
	Inverter heat pump			
Model name	ASYG07KETE ASYG07KETE-B	ASYG09KETE ASYG09KETE-B	ASYG12KETE ASYG12KETE-B	ASYG14KETE ASYG14KETE-B
NOTES:				
<ul style="list-style-type: none"> • Specifications are based on the following conditions: <ul style="list-style-type: none"> – Cooling: Indoor temperature of 27 °CDB/19 °CWB, and outdoor temperature of 35 °CDB/24 °CWB. – Heating: Indoor temperature of 20 °CDB/15 °CWB, and outdoor temperature of 7 °CDB/6 °CWB. – Pipe length: 5 m, Height difference: 0 m. (Between outdoor unit and indoor unit.) • Protective function might work when using it outside the operation range. • *1: Maximum current is maximum value when operated within the operation range. • *2: Sound pressure level: <ul style="list-style-type: none"> – Measured values in manufacturer's anechoic chamber. – Because of the surrounding sound environment, the sound levels measured in actual installation conditions might be higher than the specified values here. • *3: Available on Google Play™ store or on App Store®. Optional WLAN adapter is also required. For details, refer to the setting manual. • This data is based on EN 14511 standard. 				

Specifications for Lot10							
Model name		ASYG07KETE ASYG07KETE-B	ASYG09KETE ASYG09KETE-B	ASYG12KETE ASYG12KETE-B	ASYG14KETE ASYG14KETE-B		
Energy efficiency class	Cooling	A ⁺⁺					
	Heating (Average)	A ⁺					
Pdesign	Cooling	kW	2.0 (35 °C)	2.5 (35 °C)	3.4 (35 °C)	4.2 (35 °C)	
	Heating (Average)		2.3 (-10 °C)	2.4 (-10 °C)	2.5 (-10 °C)	4.0 (-10 °C)	
SEER	Cooling	kWh/kWh	7.4	7.4	7.3	6.9	
SCOP	Heating (Average)		4.1	4.1	4.4	4.1	
Annual energy consumption	QCE	kWh/a	95	118	163	213	
	QHE (Average)		785	819	795	1,367	
Sound power level	Cooling	HIGH	dB (A)	54	55	57	
	Heating			56	57	58	59

2. Dimensions

2-1. Models: ASYG07KETE, ASYG09KETE, ASYG12KETE, ASYG14KETE, ASYG07KETE-B, ASYG09KETE-B, ASYG12KETE-B, and ASYG14KETE-B

Unit: mm

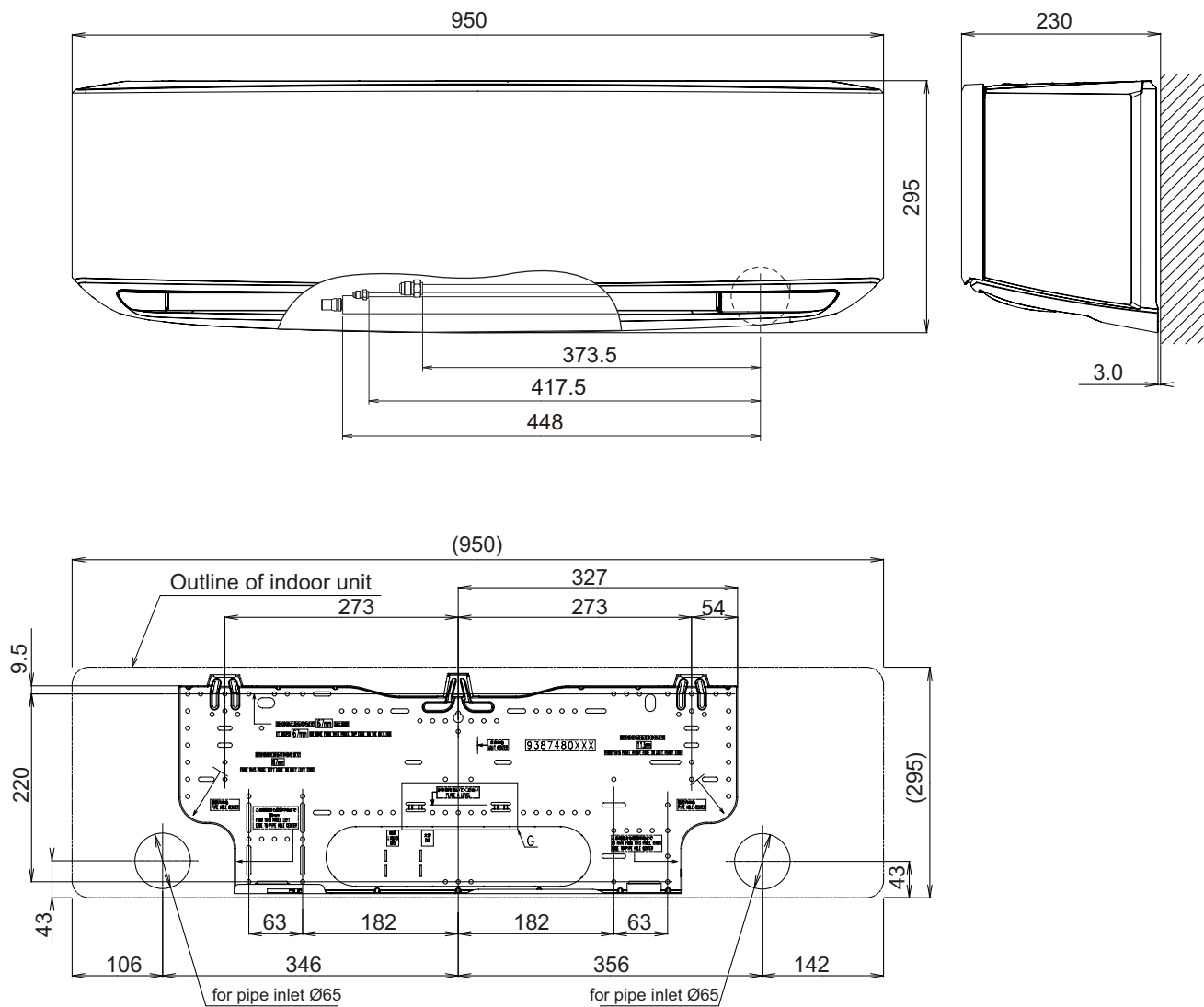

■ Installation space requirement

Provide sufficient installation space for product safety.

Unit: mm

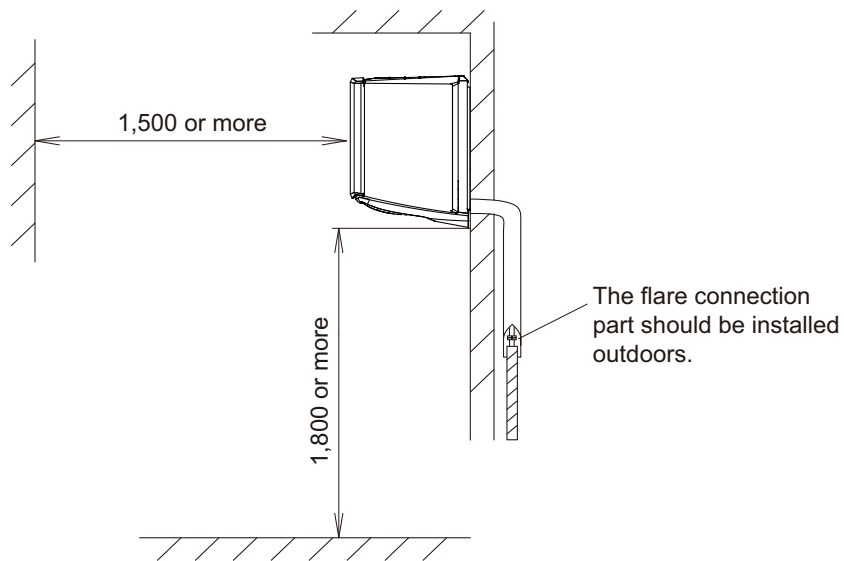
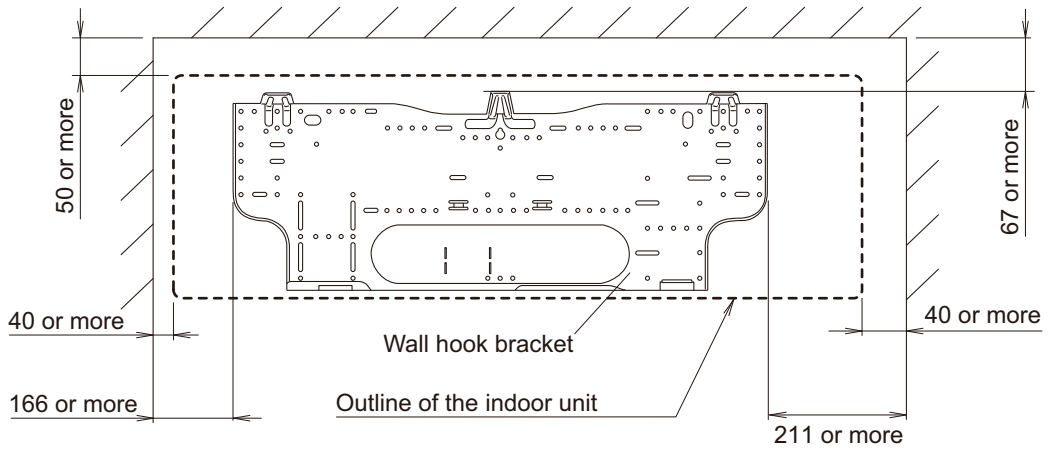

3. Wiring diagrams

3-1. Models: ASYG07KETE, ASYG09KETE, ASYG12KETE, ASYG14KETE, ASYG07KETE-B, ASYG09KETE-B, ASYG12KETE-B, and ASYG14KETE-B

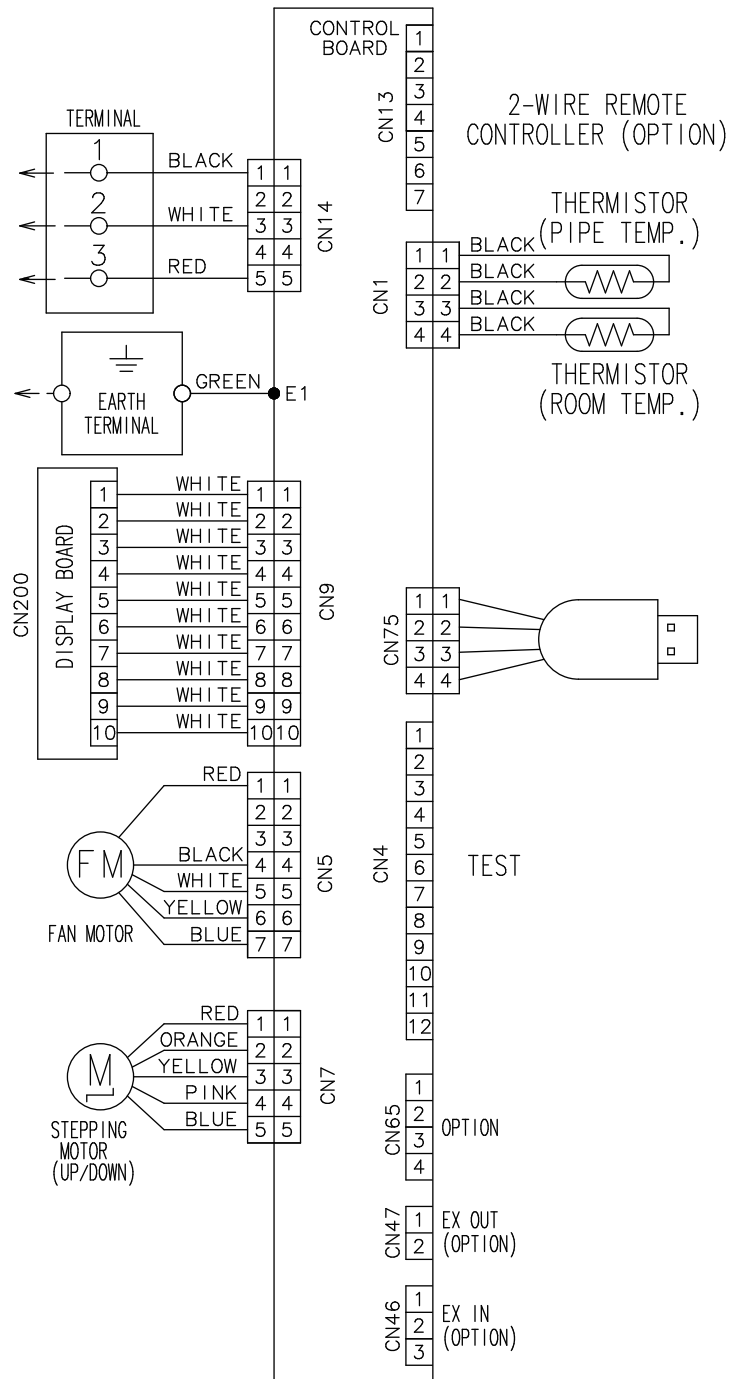

4. Capacity table

Capacity tables show each of following values calculated based on the outdoor temperature and the indoor temperature, under given Airflow Rate (AFR):

For cooling capacity: Total Capacity (TC), Sensible Heat Capacity (SHC), and Input Power (IP)

For heating capacity: Total Capacity (TC) and Input Power (IP)

4-1. Cooling capacity

■ Model: ASYG07KETE, ASYG07KETE-B

AFR		m ³ /h									650													
Outdoor temperature	Indoor temperature																							
	°CDB			18			21			23			25			27			29			32		
	°CWB			12			15			16			18			19			21			23		
	°CDB			TC	SHC	IP	TC	SHC	IP	TC	SHC	IP	TC	SHC	IP	TC	SHC	IP	TC	SHC	IP	TC	SHC	IP
	kW			kW			kW			kW			kW			kW			kW			kW		
-10	2.07	1.20	0.25	2.25	1.25	0.25	2.37	1.28	0.25	2.49	1.31	0.25	2.55	1.35	0.25	2.73	1.37	0.24	2.91	1.42	0.24			
0	2.02	1.17	0.29	2.19	1.22	0.28	2.31	1.25	0.28	2.43	1.28	0.28	2.48	1.31	0.28	2.66	1.34	0.27	2.84	1.38	0.27			
5	1.91	1.14	0.38	2.07	1.19	0.38	2.18	1.21	0.38	2.29	1.24	0.37	2.34	1.28	0.38	2.51	1.30	0.37	2.68	1.34	0.37			
10	1.96	1.13	0.36	2.13	1.17	0.36	2.24	1.20	0.35	2.36	1.23	0.35	2.41	1.27	0.35	2.58	1.29	0.35	2.75	1.33	0.34			
15	1.92	1.14	0.36	2.08	1.18	0.35	2.20	1.21	0.35	2.31	1.24	0.35	2.36	1.27	0.35	2.53	1.29	0.34	2.70	1.34	0.34			
20	1.86	1.13	0.37	2.02	1.18	0.36	2.13	1.20	0.36	2.24	1.23	0.36	2.29	1.27	0.36	2.46	1.29	0.35	2.62	1.33	0.35			
25	1.80	1.12	0.39	1.95	1.16	0.38	2.06	1.19	0.38	2.16	1.22	0.38	2.21	1.25	0.38	2.37	1.28	0.37	2.53	1.32	0.37			
30	1.72	1.10	0.42	1.87	1.14	0.41	1.97	1.17	0.41	2.07	1.20	0.41	2.11	1.23	0.41	2.27	1.25	0.40	2.42	1.30	0.40			
35	1.63	1.07	0.46	1.77	1.11	0.45	1.86	1.14	0.45	1.96	1.17	0.45	2.00	1.20	0.45	2.15	1.22	0.44	2.29	1.26	0.44			
40	1.52	1.03	0.51	1.66	1.07	0.50	1.75	1.10	0.50	1.83	1.13	0.50	1.87	1.16	0.50	2.01	1.18	0.49	2.14	1.22	0.49			
46	1.39	0.98	0.59	1.51	1.02	0.58	1.59	1.04	0.58	1.67	1.07	0.57	1.70	1.10	0.58	1.83	1.12	0.57	1.95	1.15	0.56			

■ Model: ASYG09KETE, ASYG09KETE-B

AFR		m ³ /h									700													
Outdoor temperature	Indoor temperature																							
	°CDB			18			21			23			25			27			29			32		
	°CWB			12			15			16			18			19			21			23		
	°CDB			TC	SHC	IP	TC	SHC	IP	TC	SHC	IP	TC	SHC	IP	TC	SHC	IP	TC	SHC	IP	TC	SHC	IP
	kW			kW			kW			kW			kW			kW			kW			kW		
-10	2.59	1.60	0.36	2.82	1.66	0.35	2.97	1.70	0.35	3.12	1.74	0.35	3.18	1.79	0.35	3.42	1.83	0.34	3.64	1.89	0.34			
0	2.52	1.56	0.40	2.74	1.62	0.40	2.89	1.66	0.39	3.04	1.70	0.39	3.10	1.75	0.39	3.33	1.78	0.38	3.55	1.84	0.38			
5	2.38	1.52	0.54	2.59	1.58	0.53	2.73	1.62	0.53	2.87	1.66	0.52	2.93	1.71	0.53	3.14	1.73	0.52	3.35	1.79	0.51			
10	2.45	1.51	0.50	2.66	1.57	0.50	2.80	1.60	0.50	2.95	1.64	0.49	3.01	1.69	0.50	3.23	1.72	0.49	3.44	1.78	0.48			
15	2.40	1.51	0.50	2.61	1.57	0.50	2.74	1.61	0.49	2.88	1.65	0.49	2.95	1.70	0.49	3.16	1.73	0.48	3.37	1.78	0.48			
20	2.33	1.51	0.51	2.53	1.57	0.51	2.67	1.61	0.50	2.80	1.64	0.50	2.86	1.69	0.50	3.07	1.72	0.49	3.27	1.78	0.49			
25	2.25	1.49	0.54	2.44	1.55	0.53	2.57	1.59	0.53	2.70	1.63	0.53	2.76	1.67	0.53	2.96	1.70	0.52	3.16	1.76	0.51			
30	2.15	1.47	0.58	2.33	1.52	0.58	2.46	1.56	0.57	2.58	1.60	0.57	2.64	1.64	0.57	2.83	1.67	0.56	3.02	1.73	0.56			
35	2.03	1.43	0.64	2.21	1.48	0.63	2.33	1.52	0.63	2.45	1.56	0.63	2.50	1.60	0.63	2.68	1.63	0.62	2.86	1.68	0.61			
40	1.91	1.38	0.71	2.07	1.43	0.71	2.18	1.47	0.70	2.29	1.50	0.70	2.34	1.54	0.70	2.51	1.57	0.69	2.68	1.62	0.68			
46	1.73	1.31	0.82	1.88	1.36	0.81	1.98	1.39	0.81	2.08	1.42	0.80	2.13	1.46	0.81	2.28	1.49	0.79	2.44	1.54	0.78			

■ Model: ASYG12KETE, ASYG12KETE-B

AFR		m ³ /h									700													
Outdoor temperature	Indoor temperature																							
	°CDB			18			21			23			25			27			29			32		
	°CWB			12			15			16			18			19			21			23		
	°CDB			TC	SHC	IP	TC	SHC	IP	TC	SHC	IP	TC	SHC	IP	TC	SHC	IP	TC	SHC	IP	TC	SHC	IP
	kW			kW			kW			kW			kW			kW			kW			kW		
-10	3.45	2.30	0.54	3.75	2.37	0.54	3.94	2.42	0.53	4.14	2.46	0.53	4.26	2.52	0.53	4.53	2.56	0.53	4.82	2.63	0.52			
0	3.22	2.20	0.70	3.50	2.27	0.69	3.68	2.32	0.69	3.86	2.36	0.69	3.97	2.41	0.68	4.22	2.45	0.68	4.50	2.52	0.68			
5	3.06	2.15	0.81	3.32	2.21	0.81	3.49	2.26	0.80	3.66	2.30	0.80	3.77	2.35	0.79	4.01	2.39	0.79	4.27	2.45	0.79			
10	3.35	2.31	0.61	3.63	2.38	0.61	3.82	2.43	0.60	4.01	2.47	0.60	4.12	2.53	0.59	4.38	2.57	0.60	4.67	2.64	0.59			
15	3.27	2.23	0.67	3.55	2.30	0.67	3.73	2.34	0.66	3.92	2.39	0.66	4.03	2.44	0.65	4.28	2.48	0.65	4.56	2.55	0.65			
20	3.17	2.16	0.73	3.44	2.22	0.73	3.62	2.27	0.73	3.80	2.31	0.72	3.91	2.36	0.71	4.16	2.40	0.72	4.43	2.47	0.71			
25	3.06	2.10	0.80	3.31	2.16	0.80	3.49	2.20	0.79	3.66	2.25	0.79	3.76	2.30	0.78	4.00	2.33	0.78	4.26	2.40	0.78			
30	2.92	2.05	0.88	3.17	2.11	0.87	3.33	2.15	0.87	3.49	2.19	0.87	3.59	2.24	0.86	3.82	2.28	0.86	4.07	2.34	0.85			
35	2.76	2.01	0.96	2.99	2.07	0.95	3.15	2.11	0.95	3.30	2.15	0.95	3.40	2.20	0.94	3.62	2.24	0.94	3.85	2.30	0.93			
40	2.58	1.98	1.05	2.80	2.04	1.04	2.95	2.08	1.04	3.09	2.12	1.03	3.18	2.17	1.02	3.38	2.21	1.02	3.60	2.27	1.01			
46	2.34	1.97	1.16	2.54	2.03	1.15	2.67	2.07	1.15	2.80	2.11	1.14	2.88	2.15	1.13	3.07	2.19	1.13	3.26	2.25	1.12			

■ Model: ASYG14KETE, ASYG14KETE-B

WALL MOUNTED
ASYG07-14KETE

WALL MOUNTED
ASYG07-14KETE

AFR	m ³ /h	770
-----	-------------------	-----

		Indoor temperature																				
		18			21			23			25			27			29			32		
		°CWB			15			16			18			19			21			23		
Outdoor temperature	°CDB	TC	SHC	IP	TC	SHC	IP	TC	SHC	IP	TC	SHC	IP	TC	SHC	IP	TC	SHC	IP	TC	SHC	IP
	-10	3.77	3.49	0.67	4.11	3.62	0.66	4.34	3.70	0.66	4.57	3.79	0.65	4.85	3.86	0.65	5.03	3.95	0.65	5.37	4.08	0.64
	0	3.59	3.39	0.88	3.92	3.51	0.88	4.14	3.60	0.87	4.35	3.68	0.87	4.62	3.74	0.86	4.79	3.84	0.86	5.12	3.96	0.85
	5	3.50	3.34	0.99	3.82	3.46	0.99	4.04	3.54	0.98	4.25	3.62	0.98	4.51	3.69	0.96	4.67	3.78	0.97	4.99	3.90	0.96
	10	3.64	3.40	0.63	3.97	3.52	0.62	4.19	3.60	0.62	4.41	3.68	0.62	4.68	3.75	0.61	4.85	3.84	0.61	5.19	3.97	0.61
	15	3.65	3.33	0.78	3.99	3.45	0.78	4.21	3.53	0.77	4.43	3.61	0.77	4.70	3.67	0.76	4.88	3.77	0.76	5.21	3.89	0.76
	20	3.62	3.25	0.92	3.96	3.36	0.92	4.18	3.44	0.91	4.40	3.52	0.91	4.67	3.58	0.90	4.84	3.67	0.90	5.17	3.79	0.89
	25	3.55	3.15	1.05	3.87	3.26	1.04	4.09	3.33	1.04	4.31	3.41	1.03	4.57	3.47	1.02	4.74	3.56	1.02	5.06	3.67	1.01
	30	3.43	3.03	1.16	3.74	3.14	1.15	3.95	3.21	1.15	4.16	3.28	1.14	4.42	3.34	1.13	4.58	3.43	1.13	4.89	3.54	1.12
	35	3.26	2.90	1.26	3.56	3.00	1.25	3.76	3.07	1.24	3.96	3.14	1.23	4.20	3.20	1.22	4.35	3.28	1.22	4.65	3.39	1.21
40	3.05	2.75	1.34	3.33	2.85	1.33	3.51	2.92	1.32	3.70	2.98	1.31	3.93	3.04	1.30	4.07	3.12	1.30	4.35	3.21	1.29	
46	2.73	2.55	1.41	2.98	2.65	1.40	3.15	2.71	1.40	3.31	2.77	1.39	3.52	2.82	1.37	3.65	2.89	1.37	3.90	2.98	1.36	

4-2. Heating capacity

NOTE: Values mentioned in the table are calculated based on the maximum capacity.

■ Model: ASYG07KETE, ASYG07KETE-B

AFR		m ³ /h		720											
Outdoor temperature		°CDB °CWB		Indoor temperature											
				16		18		20		22		24			
				TC	IP	TC	IP	TC	IP	TC	IP	TC	IP		
				kW		kW		kW		kW		kW		kW	
-15	-16	1.85	0.95	1.83	0.97	1.81	0.98	1.80	1.02	1.78	1.04				
-10	-11	2.22	1.00	2.20	1.02	2.17	1.03	2.16	1.07	2.14	1.10				
-5	-7	2.59	1.05	2.57	1.07	2.53	1.09	2.52	1.12	2.50	1.15				
0	-2	2.96	1.10	2.93	1.13	2.89	1.14	2.88	1.18	2.86	1.21				
5	3	3.33	1.15	3.30	1.18	3.26	1.19	3.24	1.23	3.21	1.26				
7	6	3.48	1.17	3.45	1.20	3.40	1.21	3.39	1.25	3.36	1.28				
10	8	3.70	1.20	3.67	1.23	3.62	1.24	3.60	1.29	3.57	1.32				
15	10	3.68	1.11	3.64	1.14	3.59	1.15	3.58	1.19	3.55	1.22				
20	15	3.87	1.06	3.84	1.09	3.78	1.10	3.77	1.14	3.74	1.17				
24	18	4.03	1.02	3.99	1.05	3.94	1.06	3.92	1.10	3.89	1.12				

■ Model: ASYG09KETE, ASYG09KETE-B

AFR		m ³ /h		750											
Outdoor temperature		°CDB °CWB		Indoor temperature											
				16		18		20		22		24			
				TC	IP	TC	IP	TC	IP	TC	IP	TC	IP		
				kW		kW		kW		kW		kW		kW	
-15	-16	2.14	0.99	2.13	1.02	2.12	1.02	2.12	1.06	2.11	1.09				
-10	-11	2.57	1.04	2.56	1.07	2.55	1.08	2.55	1.12	2.54	1.15				
-5	-7	3.00	1.09	2.99	1.12	2.98	1.13	2.97	1.18	2.96	1.20				
0	-2	3.43	1.15	3.42	1.17	3.40	1.19	3.40	1.23	3.39	1.26				
5	3	3.86	1.20	3.85	1.23	3.83	1.24	3.83	1.29	3.81	1.32				
7	6	4.04	1.22	4.02	1.25	4.00	1.26	4.00	1.31	3.98	1.34				
10	8	4.29	1.25	4.28	1.28	4.26	1.29	4.25	1.34	4.24	1.37				
15	10	4.43	1.26	4.42	1.29	4.39	1.30	4.39	1.35	4.37	1.38				
20	15	4.85	1.27	4.83	1.30	4.80	1.31	4.80	1.36	4.78	1.39				
24	18	5.18	1.28	5.16	1.31	5.13	1.32	5.13	1.37	5.11	1.40				

■ Model: ASYG12KETE, ASYG12KETE-B

AFR		m ³ /h		770											
Outdoor temperature		°CDB °CWB		Indoor temperature											
				16		18		20		22		24			
				TC	IP	TC	IP	TC	IP	TC	IP	TC	IP		
				kW		kW		kW		kW		kW		kW	
-15	-16	2.88	1.19	2.86	1.22	2.82	1.23	2.81	1.28	2.78	1.31				
-10	-11	3.46	1.25	3.43	1.28	3.38	1.30	3.37	1.35	3.34	1.38				
-5	-7	4.04	1.32	4.00	1.35	3.94	1.36	3.93	1.41	3.89	1.44				
0	-2	4.62	1.38	4.57	1.41	4.51	1.43	4.49	1.48	4.45	1.51				
5	3	5.19	1.44	5.15	1.48	5.07	1.49	5.05	1.55	5.01	1.58				
7	6	5.42	1.47	5.38	1.50	5.30	1.52	5.28	1.58	5.23	1.61				
10	8	5.77	1.51	5.72	1.54	5.64	1.56	5.62	1.62	5.57	1.65				
15	10	5.73	1.40	5.68	1.43	5.60	1.45	5.58	1.50	5.53	1.53				
20	15	6.04	1.34	5.98	1.37	5.90	1.38	5.88	1.43	5.82	1.47				
24	18	6.28	1.29	6.23	1.32	6.14	1.33	6.12	1.38	6.06	1.41				

■ Model: ASYG14KETE, ASYG14KETE-B

AFR		m ³ /h		800											
Outdoor temperature		°CDB °CWB		Indoor temperature											
				16		18		20		22		24			
				TC	IP	TC	IP	TC	IP	TC	IP	TC	IP		
				kW		kW		kW		kW		kW		kW	
-15	-16	3.26	1.36	3.23	1.39	3.19	1.40	3.18	1.45	3.15	1.49				
-10	-11	3.92	1.43	3.88	1.46	3.83	1.48	3.81	1.53	3.78	1.57				
-5	-7	4.57	1.50	4.53	1.54	4.47	1.55	4.45	1.61	4.41	1.64				
0	-2	5.23	1.57	5.18	1.61	5.11	1.63	5.09	1.69	5.04	1.72				
5	3	5.88	1.64	5.83	1.68	5.74	1.70	5.72	1.76	5.67	1.80				
7	6	6.14	1.67	6.09	1.71	6.00	1.73	5.98	1.79	5.92	1.83				
10	8	6.53	1.72	6.48	1.76	6.38	1.77	6.36	1.84	6.30	1.88				
15	10	6.49	1.59	6.43	1.63	6.34	1.65	6.32	1.71	6.26	1.75				
20	15	6.84	1.52	6.77	1.56	6.68	1.57	6.65	1.63	6.59	1.67				
24	18	7.11	1.47	7.05	1.50	6.95	1.52	6.92	1.57	6.86	1.61				

5. Fan performance

5-1. Air velocity distributions

■ Models: ASYG07KETE, ASYG09KETE, ASYG12KETE, ASYG07KETE-B, ASYG09KETE-B, and ASYG12KETE-B

Measuring conditions	Fan speed	Operation mode
	HIGH	FAN

Top view
Vertical airflow direction louver: Up
Horizontal airflow direction louver: Center

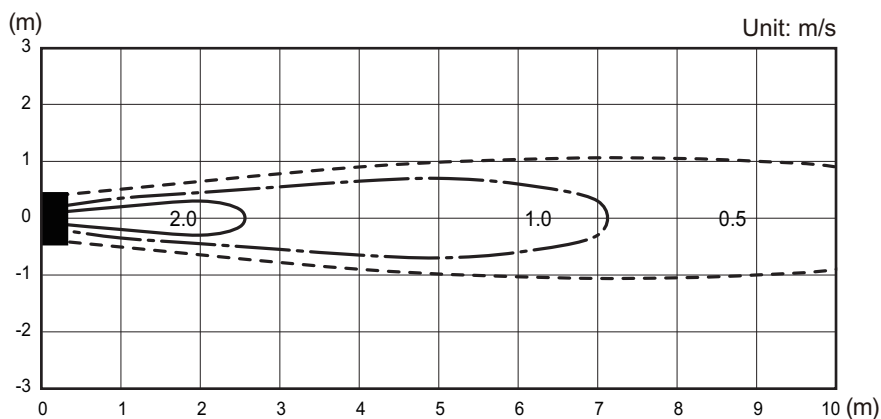

Top view
Vertical airflow direction louver: Up
Horizontal airflow direction louver: Left & Right

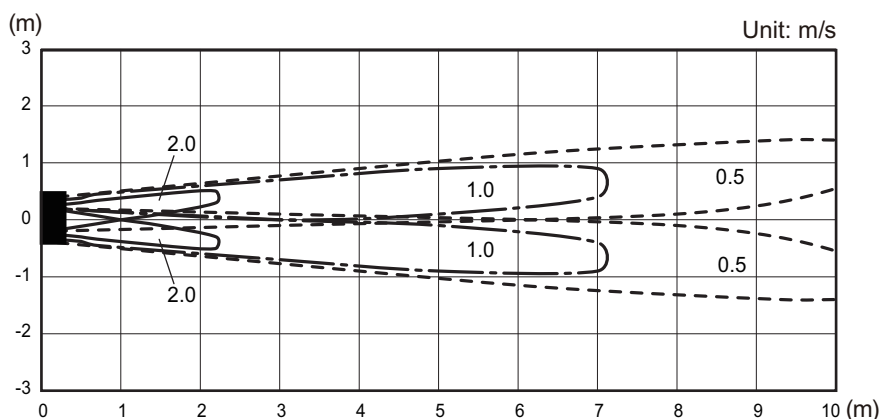

Side view
Vertical airflow direction louver: Up
Horizontal airflow direction louver: Center

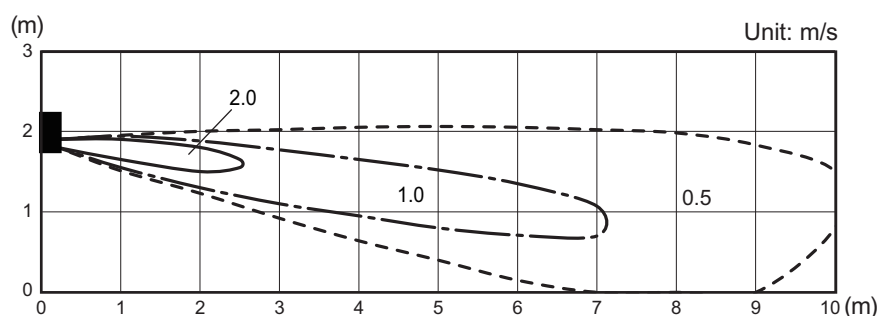

Side view
Vertical airflow direction louver: Down
Horizontal airflow direction louver: Center

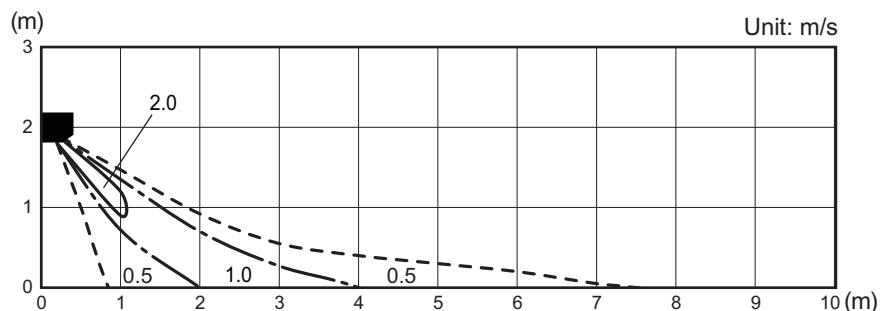

Model: ASYG14KETE, ASYG14KETE-B

WALL MOUNTED
ASYG07-14KETE

WALL MOUNTED
ASYG07-14KETE

Measuring conditions	Fan speed	Operation mode
	HIGH	FAN

Top view
Vertical airflow direction louver: Up
Horizontal airflow direction louver: Center

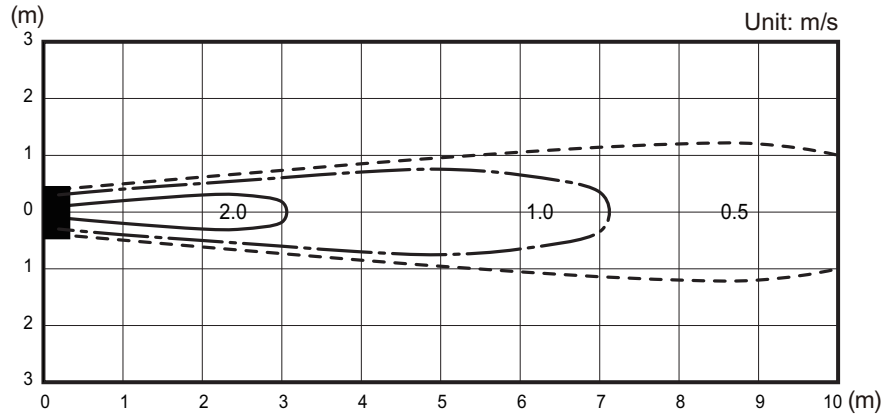

Top view
Vertical airflow direction louver: Up
Horizontal airflow direction louver: Left & Right

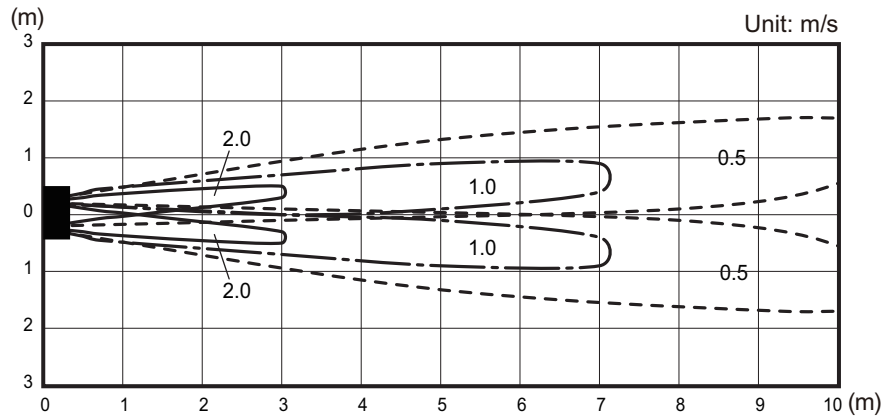

Side view
Vertical airflow direction louver: Up
Horizontal airflow direction louver: Center

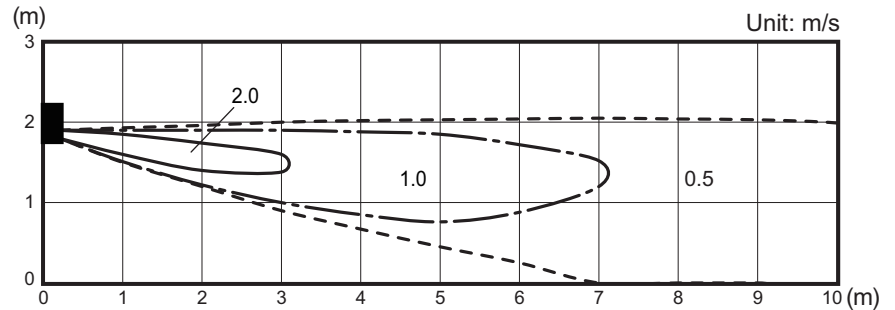

Side view
Vertical airflow direction louver: Down
Horizontal airflow direction louver: Center

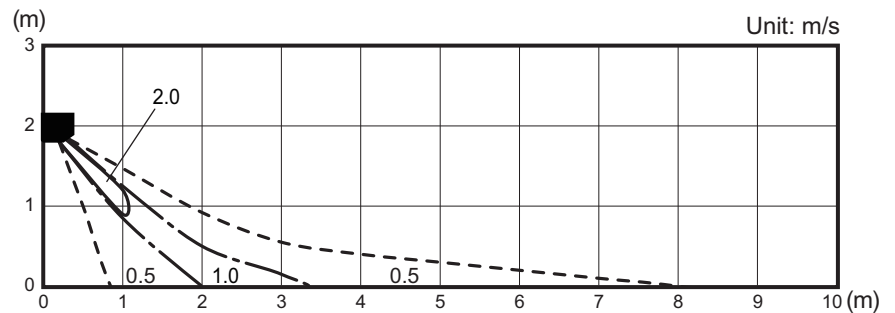

5-2. Airflow

■ Model: ASYG07KETE, ASYG07KETE-B

● Cooling

Fan speed	Airflow	
HIGH	m ³ /h	650
	l/s	181
	CFM	383
MED	m ³ /h	540
	l/s	150
	CFM	318
LOW	m ³ /h	430
	l/s	119
	CFM	253
QUIET	m ³ /h	270
	l/s	75
	CFM	159

● Heating

Fan speed	Airflow	
HIGH	m ³ /h	720
	l/s	200
	CFM	424
MED	m ³ /h	580
	l/s	161
	CFM	341
LOW	m ³ /h	460
	l/s	128
	CFM	271
QUIET	m ³ /h	330
	l/s	92
	CFM	194

■ Model: ASYG09KETE, ASYG09KETE-B

● Cooling

Fan speed	Airflow	
HIGH	m ³ /h	700
	l/s	194
	CFM	412
MED	m ³ /h	560
	l/s	156
	CFM	330
LOW	m ³ /h	430
	l/s	119
	CFM	253
QUIET	m ³ /h	270
	l/s	75
	CFM	159

● Heating

Fan speed	Airflow	
HIGH	m ³ /h	750
	l/s	208
	CFM	441
MED	m ³ /h	610
	l/s	169
	CFM	359
LOW	m ³ /h	470
	l/s	131
	CFM	277
QUIET	m ³ /h	330
	l/s	92
	CFM	194

■ Model: ASYG12KETE, ASYG12KETE-B

● Cooling

Fan speed	Airflow	
HIGH	m ³ /h	700
	l/s	194
	CFM	412
MED	m ³ /h	560
	l/s	156
	CFM	330
LOW	m ³ /h	430
	l/s	119
	CFM	253
QUIET	m ³ /h	270
	l/s	75
	CFM	159

● Heating

Fan speed	Airflow	
HIGH	m ³ /h	770
	l/s	214
	CFM	453
MED	m ³ /h	640
	l/s	178
	CFM	377
LOW	m ³ /h	520
	l/s	144
	CFM	306
QUIET	m ³ /h	330
	l/s	92
	CFM	194

■ Model: ASYG14KETE, ASYG14KETE-B

● Cooling

Fan speed	Airflow	
HIGH	m ³ /h	770
	l/s	214
	CFM	453
MED	m ³ /h	600
	l/s	167
	CFM	353
LOW	m ³ /h	450
	l/s	125
	CFM	265
QUIET	m ³ /h	280
	l/s	78
	CFM	165

● Heating

Fan speed	Airflow	
HIGH	m ³ /h	800
	l/s	222
	CFM	471
MED	m ³ /h	660
	l/s	183
	CFM	388
LOW	m ³ /h	520
	l/s	144
	CFM	306
QUIET	m ³ /h	340
	l/s	94
	CFM	200

6. Operation noise (sound pressure)

6-1. Noise level curve

Model: ASYG07KETE, ASYG07KETE-B

● Cooling

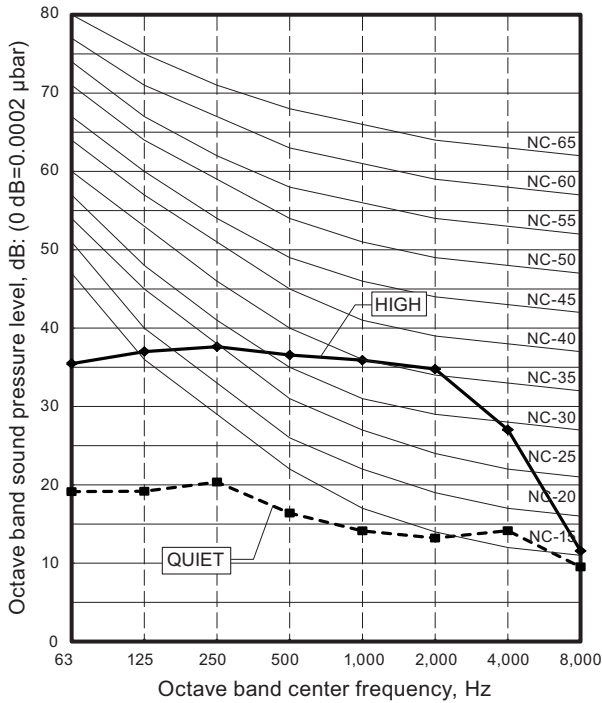

● Heating

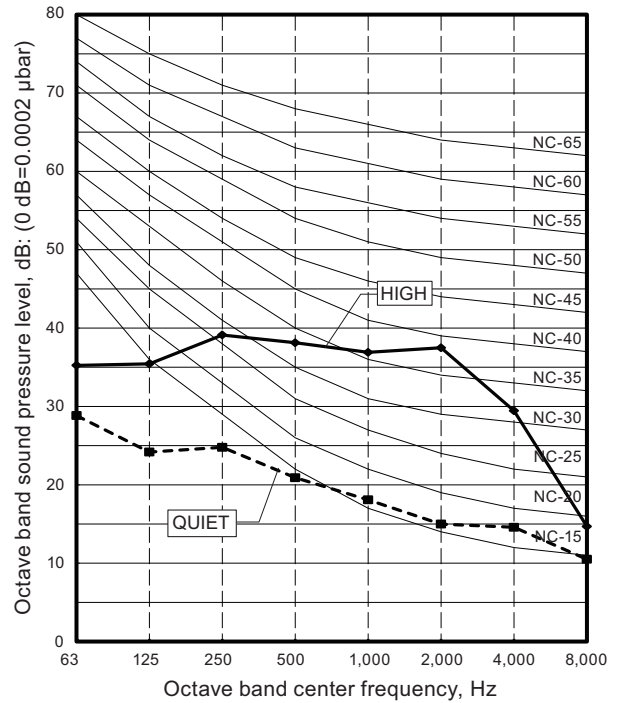

Model: ASYG09KETE, ASYG09KETE-B

● Cooling

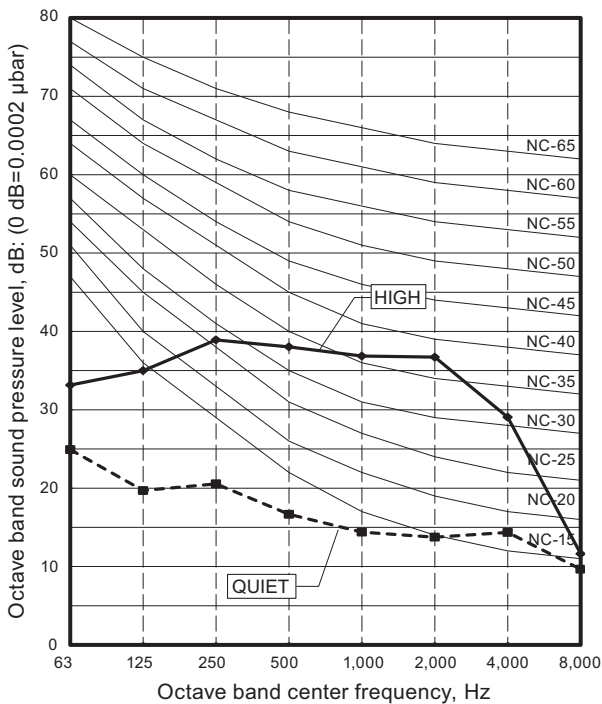

● Heating

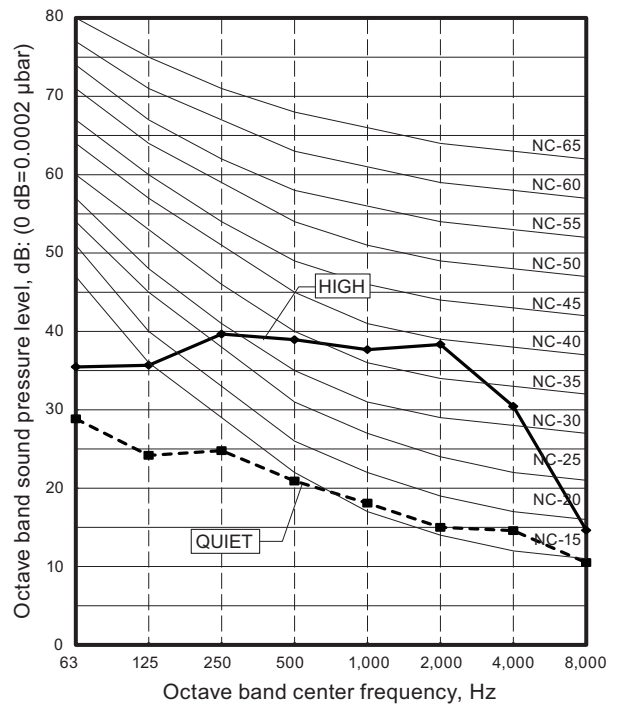

■ Model: ASYG12KETE, ASYG12KETE-B

● Cooling

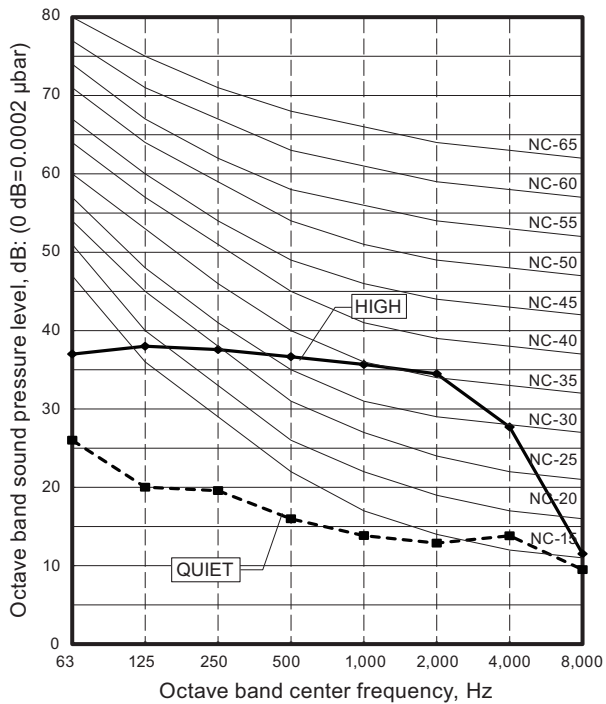

● Heating

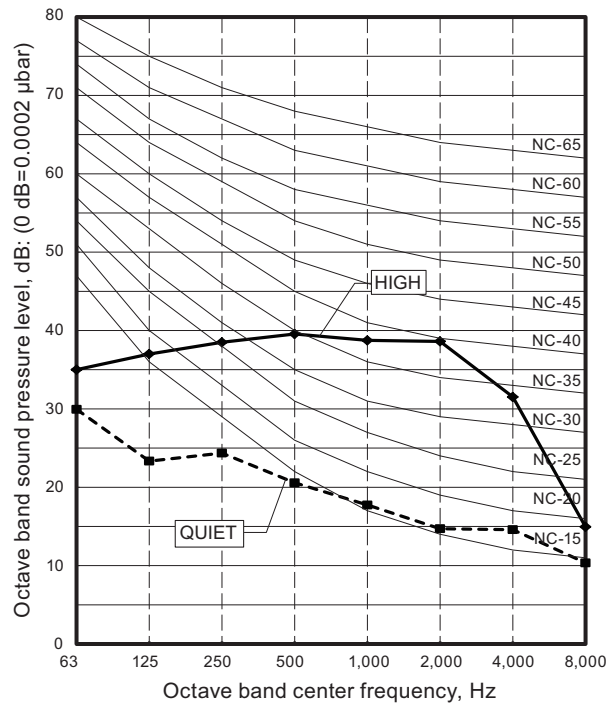

■ Model: ASYG14KETE, ASYG14KETE-B

● Cooling

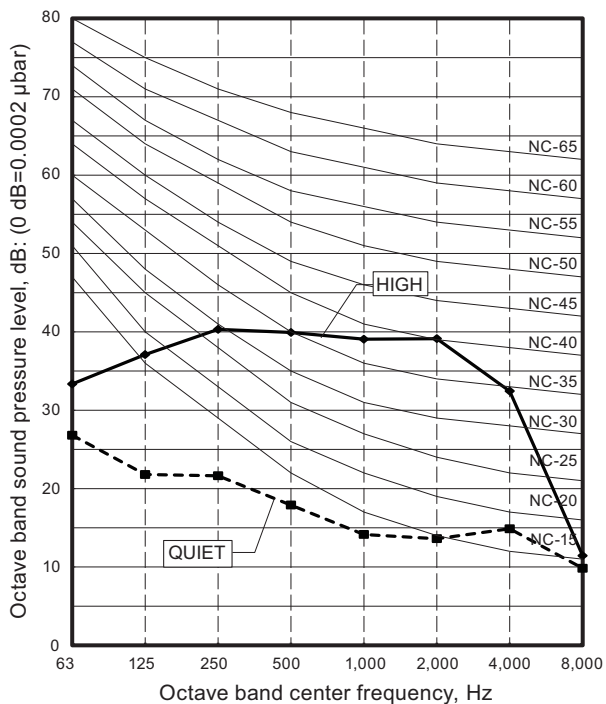

● Heating

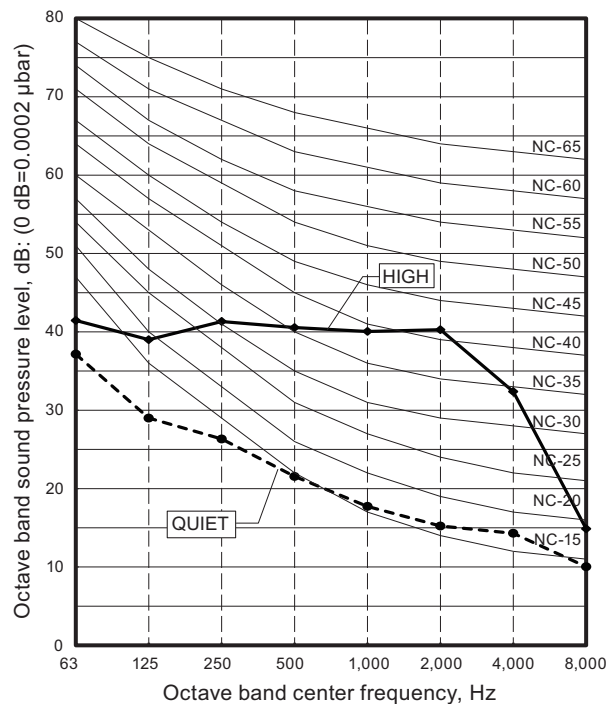

6-2. Sound level check point

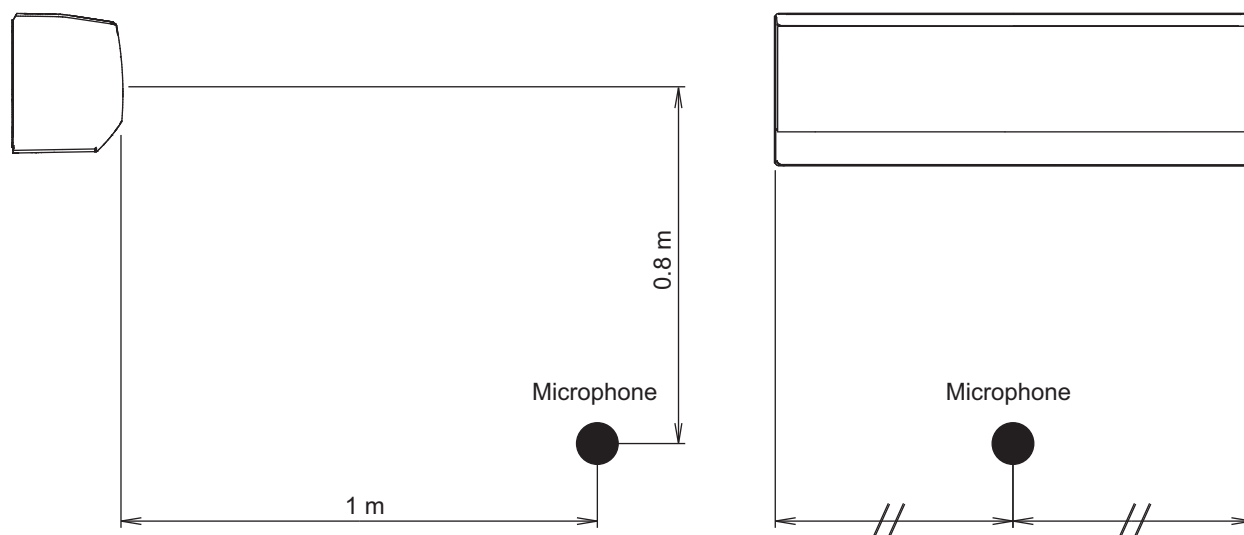

NOTE: Detailed shape of the actual indoor unit might be slightly different from the one illustrated above.

7. Safety devices

Type of protection	Protection form		Model		
			ASYG07KETE ASYG07KETE-B	ASYG09KETE ASYG09KETE-B	ASYG12KETE ASYG12KETE-B
Circuit protection	Current fuse (PCB*)		250 V, 3.15 A		
Fan motor protection	Thermistor protection	Activate	More than 85 °C Fan motor speed down		
		Reset	85 °C or less Fan motor speed recover		

Type of protection	Protection form		Model		
			ASYG14KETE ASYG14KETE-B		
Circuit protection	Current fuse (PCB*)		250 V, 3.15 A		
Fan motor protection	Power IC thermal shutdown protection	Activate	125±25 °C Fan motor stop		
		Reset	110 ⁺²⁵ ₋₂₀ °C Fan motor restart		

*PCB: Printed Circuit Board

8. External input and output

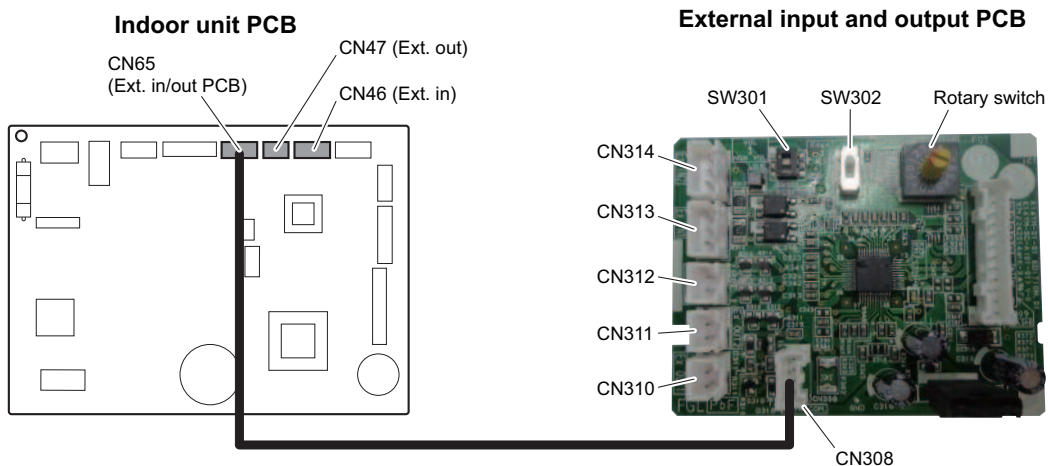

PCB	External input	External output	Connector	Input select	Input signal
Indoor unit	Operation/Stop	—	CN46	Dry contact	Edge
	Forced stop				
	—	Operation status	CN47	—	—
	Error status				
External input and output (UTY-XCSXZ2)	Operation/Stop	—	CN313/ CN314	Dry contact/ Apply voltage	Edge/Pulse
	Forced stop				
	Forced thermostat off		CN313		Edge
	—	Operation status	CN310/ CN311/ CN312	—	—
	Error status				
	Indoor unit fan operation status				

8-1. External input

With using external input function, some functions on this product can be controlled from an external device.

- "Operation/Stop" mode or "Forced stop" mode can be selected with function setting of indoor unit.
- A twisted pair cable should be used. Maximum length of cable is 150 m.
- The wire connection should be separate from the power cable line.

■ Indoor unit

Indoor unit functions such as Operation/Stop can be done by using indoor unit connectors.

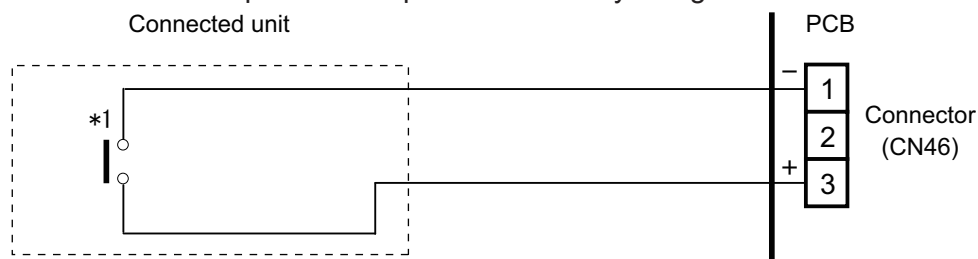

*1: The switch can be used on the following condition: DC 12 V to 24 V, 1 mA to 15 mA.

External input and output PCB

The indoor unit Operation/Stop can be set by using the input connector on the PCB.

Input select:

Use either one of these types of connectors according to the application. (Both types of connectors cannot be used simultaneously.)

– Dry contact

In case of internal power supply, set the slide switch of SW301 to "NON VOL" side.

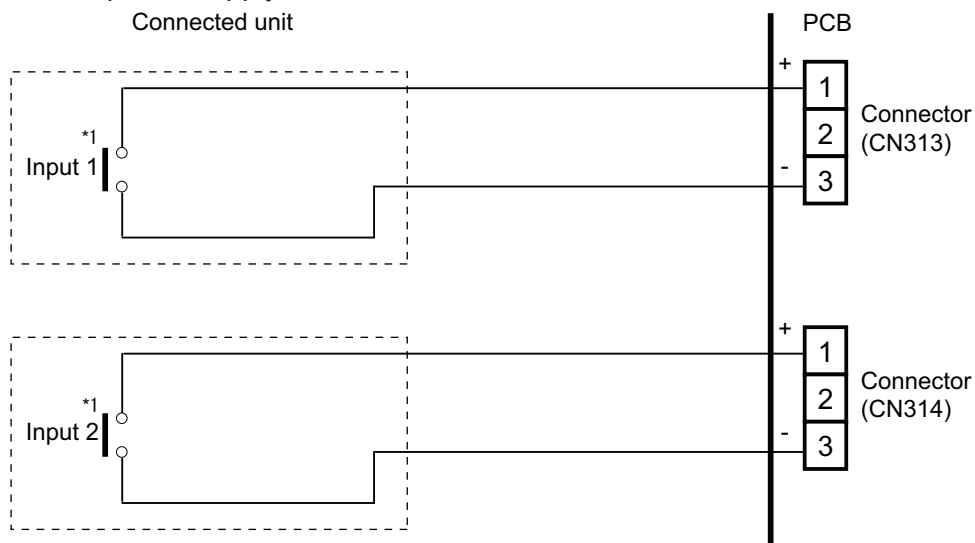

*1: The switches can be used on the following condition: DC 12 V to 24 V, 1 mA to 15 mA.

– Apply voltage

In case of external power supply, set the slide switch of SW301 to "VOL" side.

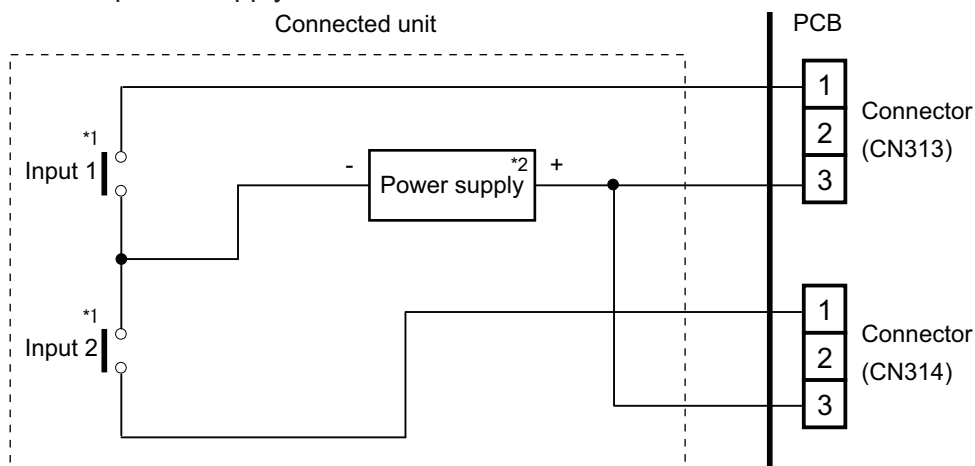

*1: The switches can be used on the following condition: DC 12 V to 24 V, 1 mA to 15 mA.

*2: Make the power supply DC 12 to 24 V, 10 mA or more.

8-2. External output

Use an external output cable with appropriate external dimension, depending on the number of cables to be installed.

■ Indoor unit

- A twisted pair cable should be used. Maximum length of cable is 25 m.
- Output voltage: High DC 12 V \pm 2 V, Low 0 V.
- Permissible current: 50 mA
- For details, refer to ["Combination of external input and output"](#) on page 25

● When indicator or other components are connected directly

Example: Function setting 60 is set to "00"

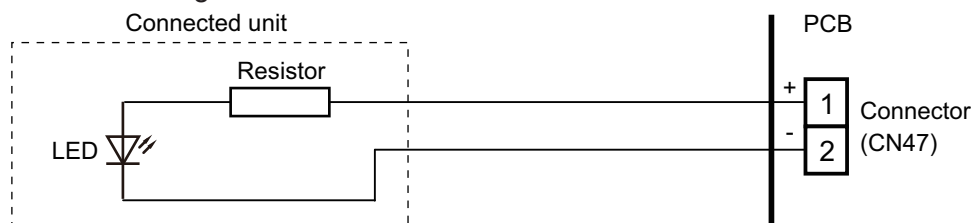

● When connecting with a device equipped with a power supply

Example: Function setting 60 is set to "00"

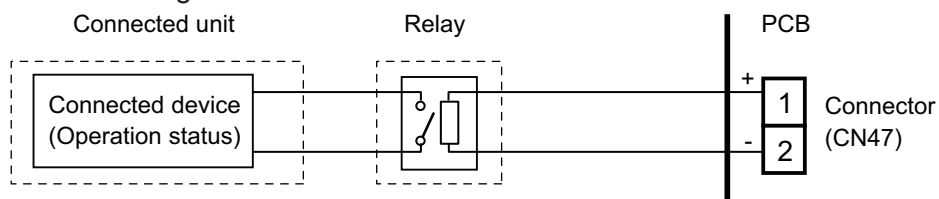

External input and output PCB

- A twisted pair cable should be used. Maximum length of cable is 25 m.
 - Output voltage: High DC 12 V±2 V, Low 0 V.
 - Permissible current: 50 mA
 - For details, refer to "[Combination of external input and output](#)" on page 25
- **When indicator or other components are connected directly:**
Example: Rotary SW on External input and output PCB is set to "1".

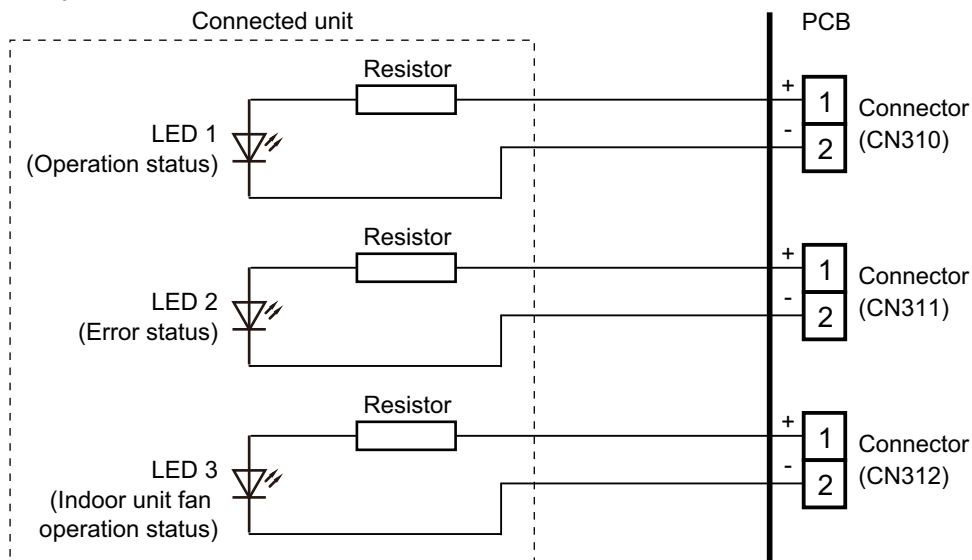

- **When connecting with a device equipped with a power supply:**
Example: Rotary SW on External input and output PCB is set to "1".

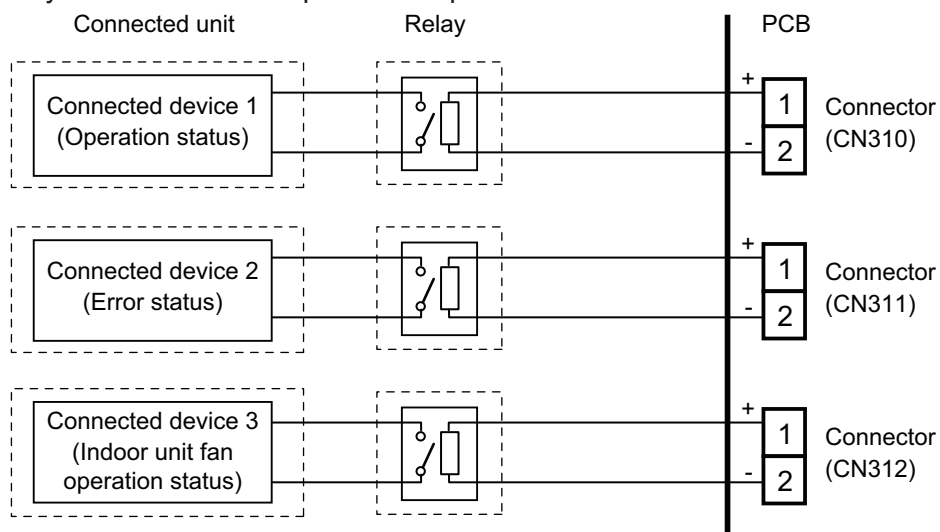

8-3. Combination of external input and output

By combining the function setting of the indoor unit and rotary switch setting of the External input and output PCB, you can select various combinations of functions.

Combination examples of external input and output are as follows:

Mode	Function setting	Rotary SW	External input		
			Indoor unit	External input and output PCB	
			CN46	CN313	CN314
0-1	60—00	1	Operation/Stop mode1 (Function setting 46-00)	Operation/Stop	Not available
			or	Operation	Stop
0-2	60-00	2	Forced stop (Function setting 46-02)	Forced thermostat OFF	Not available
			or		
			Operation/Stop mode2 (Function setting 46-03)		
1—8	60-01—08	3—9, A	(Setting prohibited)		
9	60-09	B	Operation/Stop mode1 (Function setting 46-00)	Forced thermostat OFF	Not available
			or		
			Forced stop (Function setting 46-02)		
			or		
10	60-10	C	Operation/Stop mode2 (Function setting 46-03)		
11	60-11	D	(Setting prohibited)		

Mode	Function setting	Rotary SW	External output			
			Indoor unit	External input and output PCB		
			CN47	CN310	CN311	CN312
0-1	60-00	1	Operation/Stop	Operation/Stop	Error status	Indoor unit fan operation status
0-2	60-00	2	Operation/Stop	Error status	Indoor unit fan operation status	Not available
1—8	60-01—08	3—9, A	(Setting prohibited)			
9	60-09	B	Error status	Operation/Stop	Indoor unit fan operation status	Not available
10	60-10	C	Indoor unit fan operation status		Error status	
11	60-11	D	(Setting prohibited)			

NOTE: Input of Operation/Stop depends on the setting of function setting 46.

00: Operation/Stop mode 1 (R.C. enabled)

01: (Setting prohibited)

02: Forced stop

03: Operation/Stop mode 2 (R.C. disabled)

■ Input signal type

External input and output PCB:

The input signal type can be selected.

Signal type (edge or pulse) can be switched by the DIP switch SW302 on the External input and output PCB.

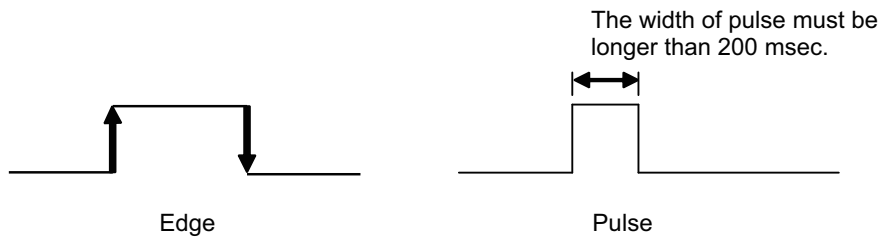

8-4. Details of function

■ Control input function

- When function setting is “Operation/Stop” mode 1
 - In the case of “Edge” input:

Function setting	Rotary SW on External input and output PCB	External input		Input signal	Command
		External input and output PCB	CN313		
46-00	1			Off → On	Operation
				On → Off	Stop

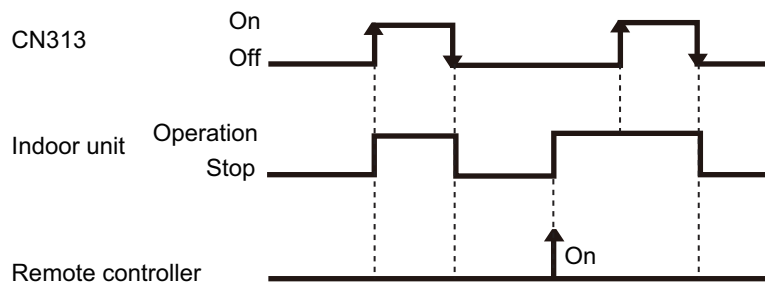

- In the case of “Pulse” input:

Function setting	Rotary SW on External input and output PCB	External input		Input signal	Command
		External input and output PCB	CN313		
46-00	1		CN313	Pulse	Operation
			CN314	Pulse	Stop

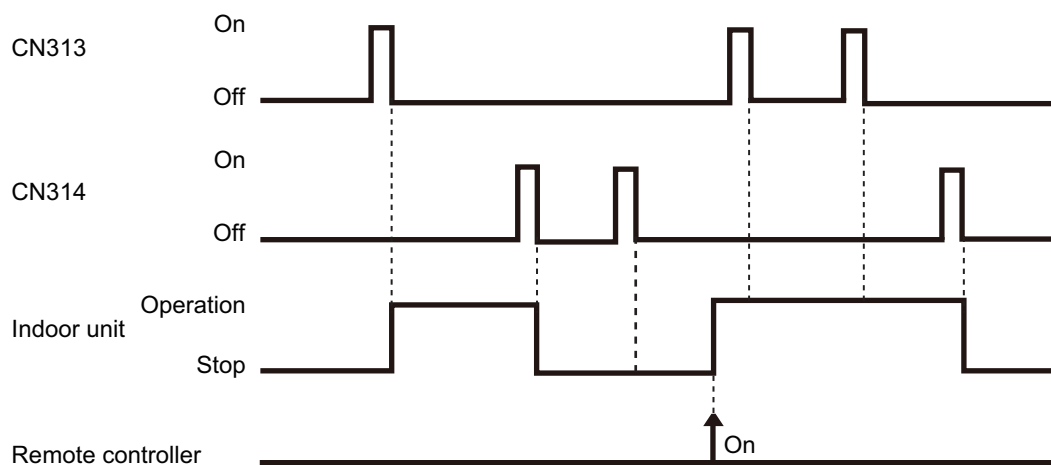

NOTES:

- The last command has priority.
- The indoor units within the same remote controller group operates in the same mode.

• When function setting is “Forced stop” mode

– In the case of “Edge” input:

Function setting	Rotary SW on External input and output PCB	External input		Input signal	Command
		External input and output PCB	CN313		
46-02	1			Off → On	Forced stop
				On → Off	Normal

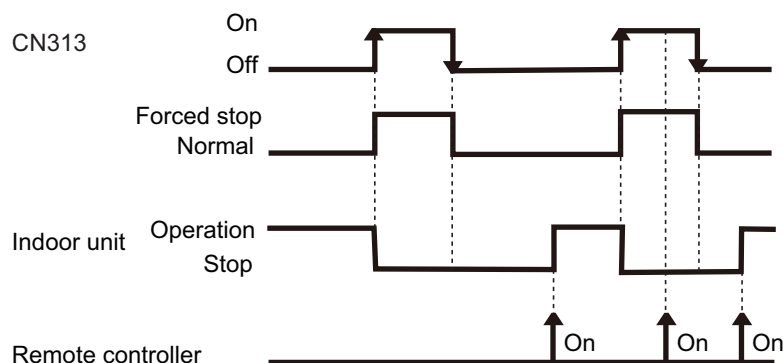

– In the case of “Pulse” input:

Function setting	Rotary SW on External input and output PCB	External input		Input signal	Command
		External input and output PCB	CN313 CN314		
46-02	1		CN313	Pulse	Forced stop
			CN314	Pulse	Normal

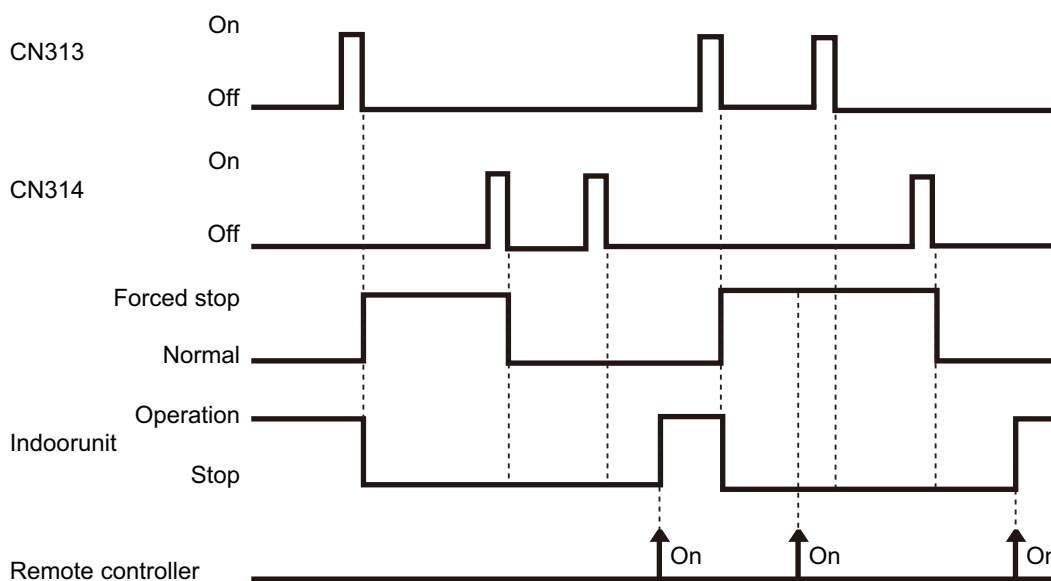

NOTES:

- When the forced stop is triggered, indoor unit stops and Operation/Stop operation by the remote controller is restricted.
- When forced stop function is used with forming a remote controller group, connect the same equipment to each indoor unit within the group.

• When function setting is “Operation/Stop” mode 2

– In the case of “Edge” input:

Function setting	Rotary SW on External input and output PCB	External input		Input signal	Command
46-03	1	External input and output PCB	CN313	Off → On	Operation
				On → Off	Stop (R.C. disabled)

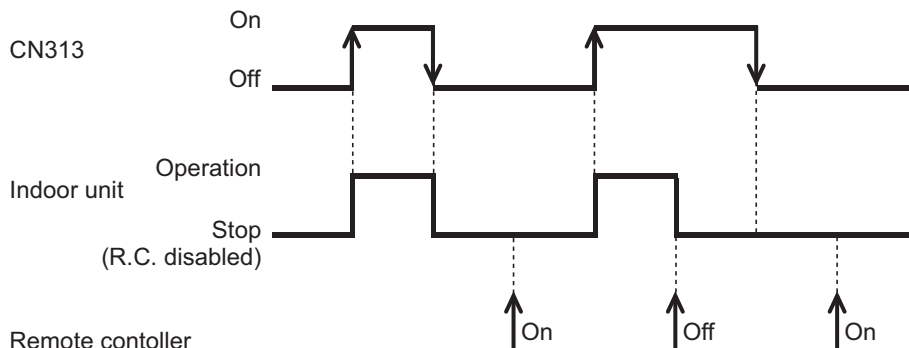

– In the case of “Pulse” input:

Function setting	Rotary SW on External input and output PCB	External input		Input signal	Command
46-03	1	External input and output PCB	CN313	Pulse	Operation
			CN314	Pulse	Stop (R.C. disabled)

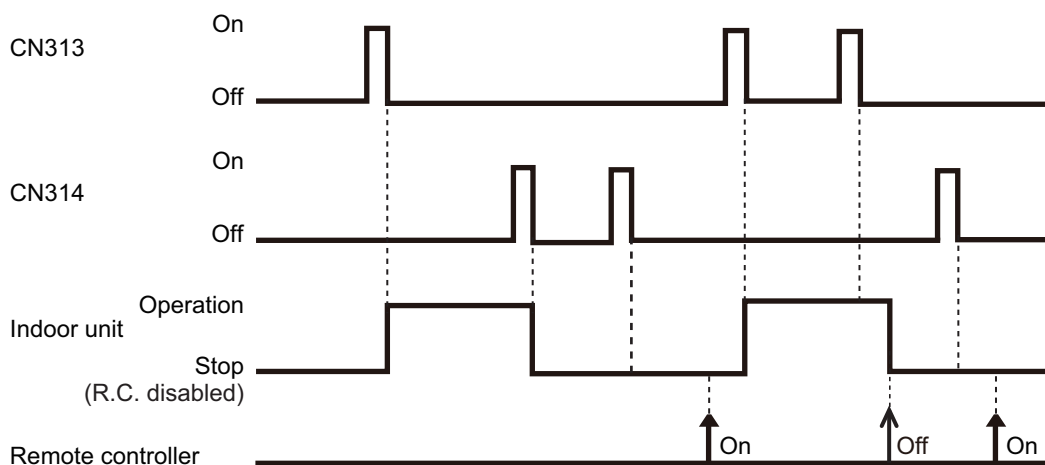

NOTE: When “Operation/Stop” mode 2 function is used with forming a remote controller group, connect the same equipment to each indoor unit within the group.

• Forced thermostat off function

Function setting / Rotary SW on External input and output PCB	External input		Input signal	Command
60-00 / 2 60-09 / B 60-10 / C	External input and output PCB	CN313	Off → On	Thermostat off
On → Off			Normal operation	

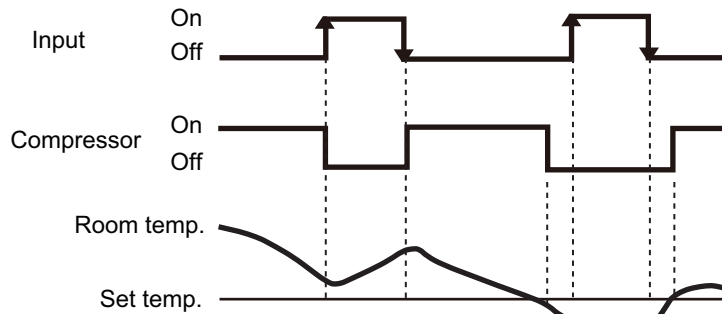

Control output function

• Operation/Stop status

Function setting / Rotary SW on External input and output PCB	External output		Output signal	Command
60-00 / 1 60-00 / 2	Output of indoor unit	CN47	Off → On	Operation
			On → Off	Stop
60-00 / 1 60-09 / B 60-10 / C 60-11 / D	External input and output PCB	CN310	Off → On	Operation
			On → Off	Stop

The output is low when the unit is stopped.

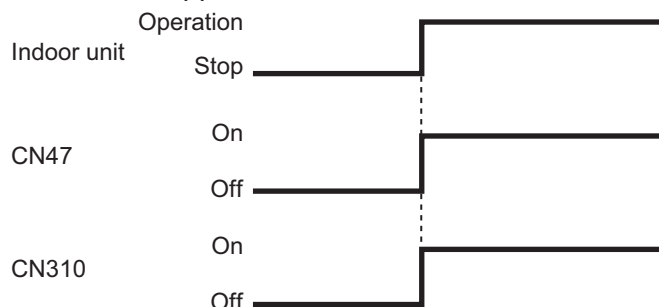

• Error status

Function setting / Rotary SW on External input and output PCB	External output		Output signal	Command
60-09 / B	Output of indoor unit	CN47	Off → On	Error
			On → Off	Normal
60-00 / 2	External input and output PCB	CN310	Off → On	Error
			On → Off	Normal
60-00 / 1 60-10 / C	External input and output PCB	CN311	Off → On	Error
			On → Off	Normal
60-11 / D	External input and output PCB	CN312	Off → On	Error
			On → Off	Normal

The output is ON when an error is generated for the indoor unit.

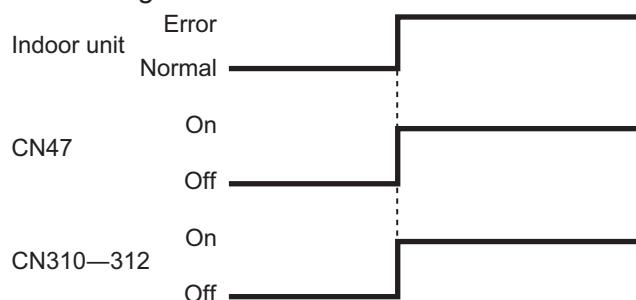

- Indoor unit fan operation status

Function setting / Rotary SW on External input and output PCB	External output		Output signal	Command
60-10 / C	Output of indoor unit	CN47	Off → On	Fan run
			On → Off	Fan stop
60-00 / 2 60-09 / B 60-11 / D	External input and output PCB	CN311	Off → On	Fan run
			On → Off	Fan stop
60-00 / 1		CN312	Off → On	Fan run
			On → Off	Fan stop

Output signal	Condition
On Low → High	The indoor unit fan is operating.
Off High → Low	The fan is stopped or during cold air prevention. During thermostat off when in dry mode operation.

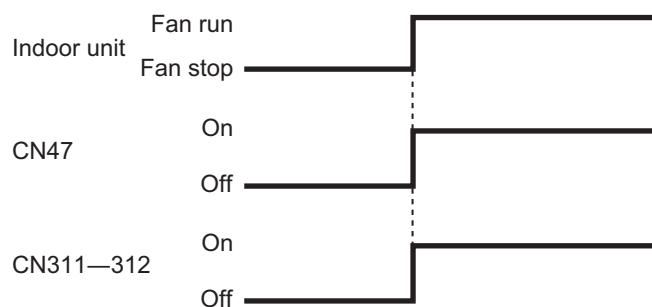

9. Group connection

NOTE: Group control cannot be used together with Wireless LAN adapter.

Installation procedure for group control system:

A number of indoor units can be operated at the same time using a single remote controller.

NOTE: When different type of indoor units (such as wall mounted type and cassette type, cassette type and duct type, or other combinations) are connected using group control system, some functions may no longer be available.

1. Connect up to 16 indoor units in a system.

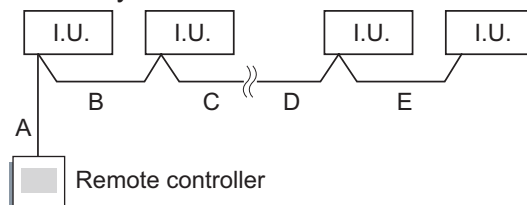

A, B, C, D, E: Remote controller cable	
Wiring length limitation	$A + B + C + D + E \leq 500 \text{ m}$

Example of wiring method

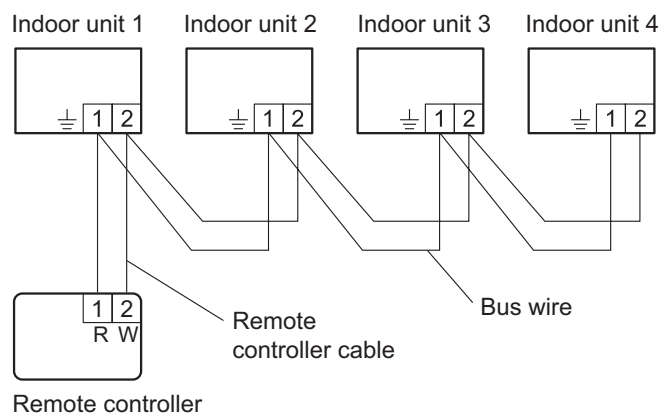

10. Remote controller

10-1. Wireless remote controller

Overview

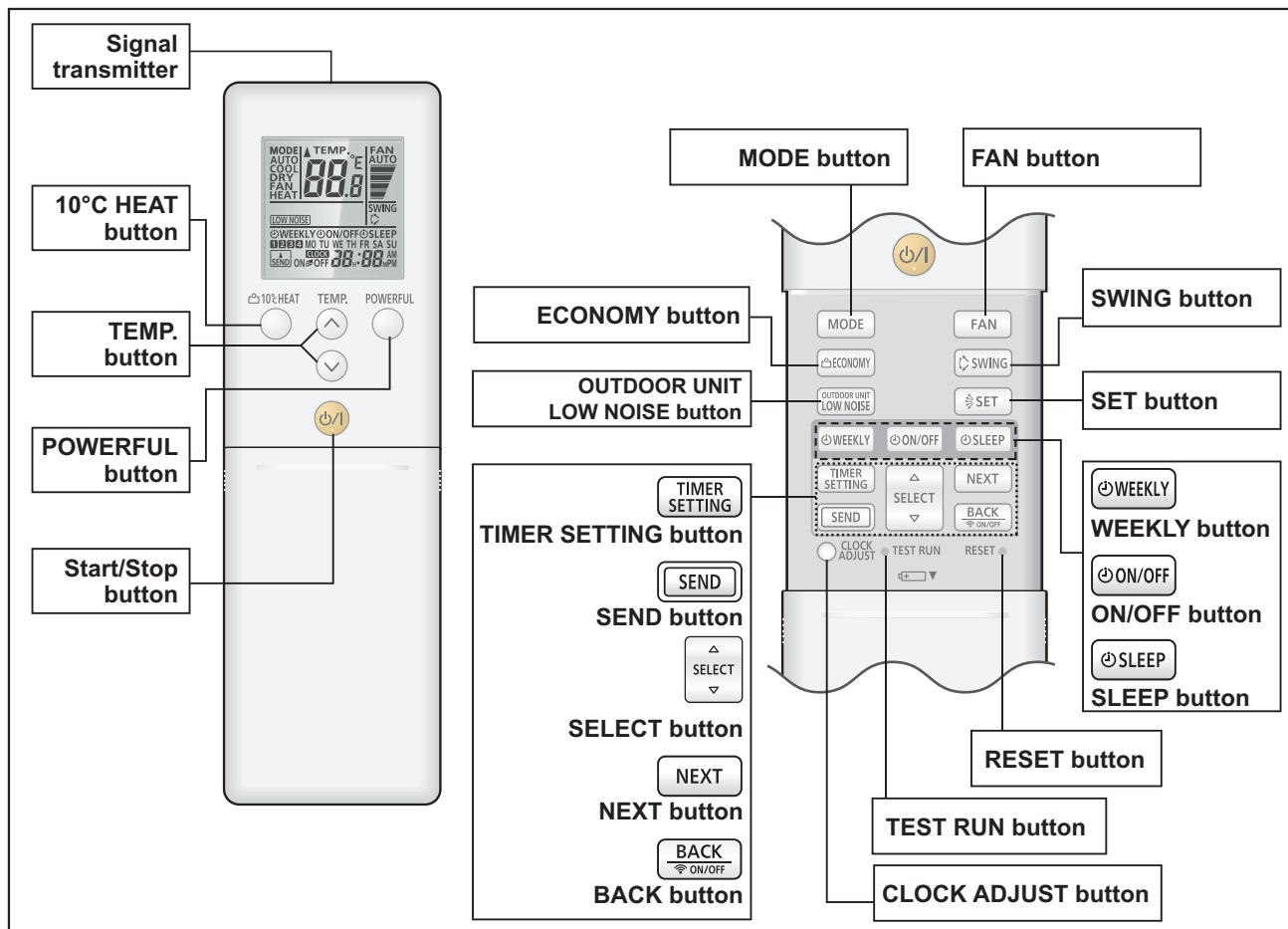

NOTE: Functions may differ by type of the indoor unit. For details, refer to the operation manual.

Display panel

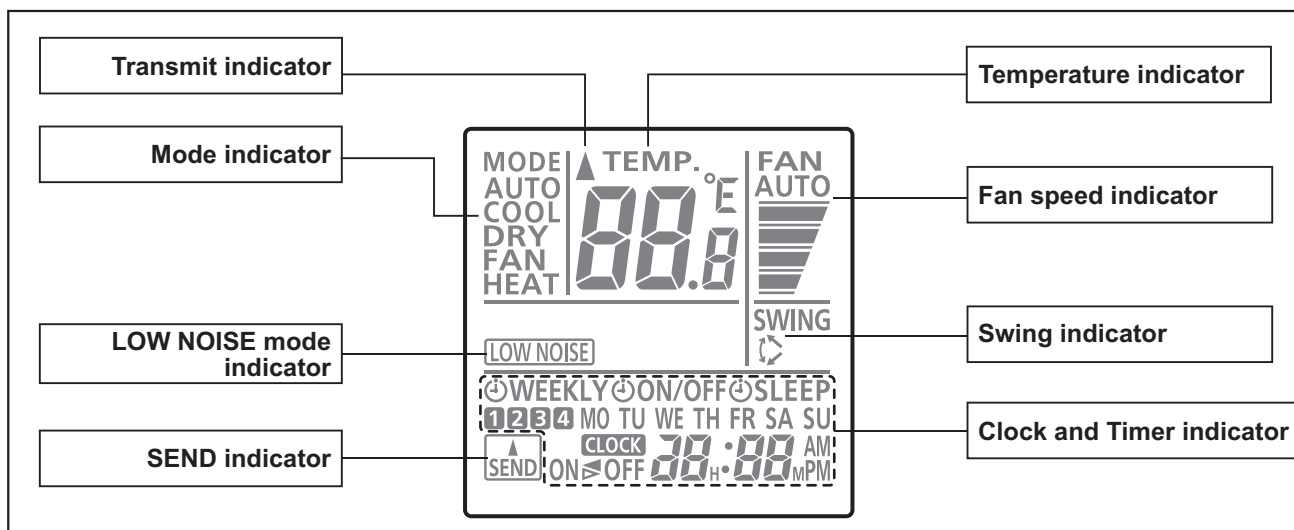

To facilitate explanation, the accompanying illustration has been drawn to show all possible indicators; in actual operation, however, the display will only show those indicators appropriate to the current operation.

Specifications

● Controller

Unit: mm

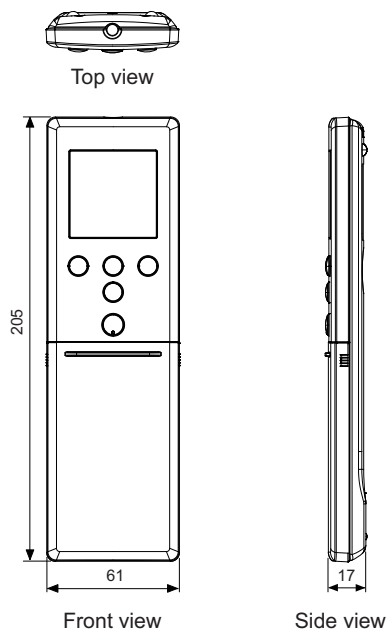

Size (H × W × D)	mm	205 × 61 × 17
Weight	g	124 (without batteries)

● Holder

Unit: mm

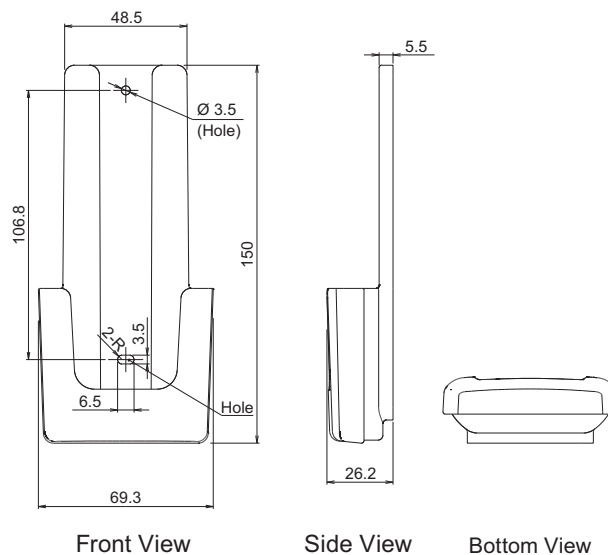

Size (H × W × D)	mm	150 × 69.3 × 26.2
Weight	g	27

11. Function settings

To adjust the functions of this product according to the installation environment, various types of function settings are available.

NOTE: Incorrect settings can cause a product malfunction.

11-1. Function settings by using remote controller

Some function settings can be changed on the remote controller. After confirming the setting procedure and the content of each function setting, select appropriate functions for your installation environment.

■ Setting procedure by using wireless remote controller

The function number and the associated setting value are displayed on the LCD of the remote controller. Follow the instructions written in the local setup procedure supplied with the remote controller, and select appropriate setting according to the installation environment.

Before connecting the power supply of the indoor unit, reconfirm following items:

- Cover for the electrical enclosure on the outdoor unit is in place.
- There is no wiring mistake.
- Piping air tight test and vacuuming have been performed firmly.
- All the necessary wiring work for outdoor unit has been finished.

After reconfirming the items listed above, connect the power supply of the indoor unit.

NOTES:

- Settings will not be changed if invalid numbers or setting values are selected.
- When optional wired remote controller is used, refer to the installation manual enclosed with the remote controller.

Entering function setting mode:

While pressing the POWERFUL button and TEMP. (^) button simultaneously, press the RESET button to enter the function setting mode.

Selecting the function number and setting value:

1. Press the TEMP. (^) (v) buttons to select the function number. To switch between the left and right digits, press the 10 °C HEAT button.
2. Press the POWERFUL button to proceed to value setting. To return the function number selection, press the POWERFUL button again.
3. Press the TEMP. (^) (v) buttons to select the setting value. To switch between the left and right digits, press the 10 °C HEAT button.
4. Press the MODE button once. Confirm that you hear the beep sound.
5. Press the START/STOP button to fix the function setting. Confirm that you hear the beep sound.
6. Press the RESET button to end the function setting mode.
7. After completing the function setting, be sure to disconnect the power supply and then reconnect it.



⚠ CAUTION

After disconnecting the power supply, wait 30 seconds or more before reconnecting it. The function setting will not become active unless the power supply is disconnected and then reconnected.

NOTES:

- The air conditioner custom code is set to H prior to shipment.
- If you do not know the air conditioner custom code setting, try each of the custom codes ($\text{H} \rightarrow \text{b}$
 $\rightarrow \text{c} \rightarrow \text{d}$) until you find the code that operates the air conditioner.

■ Contents of function setting

Each function setting listed in this section is adjustable in accordance with the installation environment.

NOTE: Setting will not be changed if invalid numbers or setting values are selected.

● Function setting list

	Function no.	Functions
1)	11	Filter sign
2)	30/31	Room temperature control for indoor unit sensor
3)	35/36	Room temperature control for wired remote controller sensor
4)	40	Auto restart
5)	42	Room temperature sensor switching
6)	44	Remote controller custom code
7)	46	External input control
8)	48	Room temperature sensor switching (Aux.)
9)	49	Indoor unit fan control for energy saving for cooling
10)	60	Switching functions for external output terminal

1) Filter sign

Select appropriate intervals for displaying the filter sign on the indoor unit according to the estimated amount of dust in the air of the room.

If the indication is not required, select "No indication" (03).

Function number	Setting value	Setting description	Factory setting
11	00	Standard (400 hours)	
	01	Long interval (1,000 hours)	
	02	Short interval (200 hours)	
	03	No indication	◆

2) Room temperature control for indoor unit sensor

Depending on the installed environment, correction of the room temperature sensor may be required. Select the appropriate control setting according to the installed environment.

The temperature of the room temperature sensor is corrected as follows:

Corrected temp. = Temp. of the room temp. sensor - Correction temp. value

Example of correction:

When the temperature of the room temp. sensor is 26°C and the setting value is "03" (-1.0°C), corrected temp. will be 27°C (26°C - [-1.0°C]).

The temperature correction values show the difference from the Standard setting "00" (manufacturer's recommended value).

Function number		Setting value	Setting description	Factory setting	
30 (For cooling)	31 (For heating)	00	Standard setting	◆	
		01	No correction 0.0 °C		
		02	-0.5 °C	More cooling Less heating	
		03	-1.0 °C		
		04	-1.5 °C		
		05	-2.0 °C		
		06	-2.5 °C		
		07	-3.0 °C		
		08	-3.5 °C		
		09	-4.0 °C		
		10	+0.5 °C	Less cooling More heating	
		11	+1.0 °C		
		12	+1.5 °C		
		13	+2.0 °C		
		14	+2.5 °C		
		15	+3.0 °C		
		16	+3.5 °C		
17	+4.0 °C				

3) Room temperature control for wired remote controller sensor

Depending on the installed environment, correction of the wire remote temperature sensor may be required. Select the appropriate control setting according to the installed environment.

To change this setting, set Function 42 to Both "01".

Ensure that the Thermo Sensor icon is displayed on the remote controller screen.

Function number		Setting value	Setting description	Factory setting	
35 (For cooling)	36 (For heating)	00	Standard setting	◆	
		01	No correction 0.0°C		
		02	-0.5 °C	More cooling Less heating	
		03	-1.0 °C		
		04	-1.5 °C		
		05	-2.0 °C		
		06	-2.5 °C		
		07	-3.0 °C		
		08	-3.5 °C		
		09	-4.0 °C		
		10	+0.5 °C	Less cooling More heating	
		11	+1.0 °C		
		12	+1.5 °C		
		13	+2.0 °C		
		14	+2.5 °C		
		15	+3.0 °C		
		16	+3.5 °C		
17	+4.0 °C				

4) Auto restart

Enables or disables automatic restart after a power interruption.

Function number	Setting value	Setting description	Factory setting
40	00	Enable	◆
	01	Disable	

NOTE: Auto restart is an emergency function such as for power outage etc. Do not attempt to use this function in normal operation. Be sure to operate the unit by remote controller or external device.

5) Room temperature sensor switching

(Only for wired remote controller)

When using the wired remote controller temperature sensor, change the setting to "Both" (01).

Function number	Setting value	Setting description	Factory setting
42	00	Indoor unit	◆
	01	Both	

00: Sensor on the indoor unit is active.

01: Sensors on both indoor unit and wired remote controller are active.

NOTE: Remote controller sensor must be turned on by using the remote controller.

6) Remote controller custom code

(Only for wireless remote controller)

The indoor unit custom code can be changed. Select the appropriate custom code.

Function number	Setting value	Setting description	Factory setting
44	00	A	◆
	01	B	
	02	C	
	03	D	

7) External input control

"Operation/Stop" mode or "Forced stop" mode can be selected.

Function number	Setting value	Setting description	Factory setting
46	00	Operation/Stop mode 1 (R.C. enabled)	◆
	01	(Setting prohibited)	
	02	Forced stop mode	
	03	Operation/Stop mode 2 (R.C. disabled)	

8) Room temperature sensor switching (Aux.)

To use the temperature sensor on the wired remote controller only, change the setting to "Wired remote controller" (01).

This function will only work if the function setting 42 is set at "Both" (01).

When the setting value is set to "Both" (00), more suitable control of the room temperature is possible by setting function setting 30 and 31 too.

Function number	Setting value	Setting description	Factory setting
48	00	Both	◆
	01	Wired remote controller	

9) Indoor unit fan control for energy saving for cooling

Enables or disables the power-saving function by controlling the indoor unit fan rotation when the outdoor unit is stopped during cooling operation.

Function number	Setting value	Setting description	Factory setting
49	00	Disable	
	01	Enable	
	02	Remote controller	◆

00: When the outdoor unit is stopped, the indoor unit fan operates continuously following the setting on the remote controller.

01: When the outdoor unit is stopped, the indoor unit fan operates intermittently at a very low speed.

02: Enable or disable this function by remote controller setting.

NOTES:

- As the factory setting, this setting is initially activated.
- Set to "00" or "01" when connecting a remote controller that cannot set the Fan control for energy saving function or connecting a network converter.
To confirm if the remote controller has this setting, refer to the operating manual of each remote controller.

10) Switching functions for external output terminal

Functions of the external output terminal can be switched. For details, refer to “External input and output”.

Function number	Setting value	Setting description	Factory setting
60	00	Operation status	◆
	01—08	(Setting prohibited)	
	09	Error status	
	10	Indoor unit fan operation status	
	11	(Setting prohibited)	

11-2. Custom code setting for wireless remote controller

To interconnect the air conditioner and the wireless remote controller, assignment of the custom code for the wireless remote controller is required.

NOTE: Air conditioner cannot receive a signal if the air conditioner has not been set for the custom code.

When 2 or more air conditioners are installed in a room, and the remote controller is operating an air conditioner other than the one you wish to set, change the custom code of the remote controller to operate only the air conditioner you wish to set. (4 selections possible.)

Confirm the setting of the remote controller custom code and the function setting. If these do not match, the remote controller cannot be used to operate for the air conditioner.

1. Press the START/STOP button until only the clock is displayed on the remote controller display.
2. Press the MODE button for at least 5 seconds to display the current custom code. (Initially set to A .)
3. Press the TEMP. (\wedge) (\vee) buttons to change the custom code between $\text{A} \rightarrow \text{b} \rightarrow \text{c} \rightarrow \text{d}$. Match the code on the display to the air conditioner custom code. (Initially set to A .)
4. Press the MODE button again to return to the clock display. The custom code will be changed.









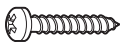

NOTES:

- If no button is pressed within 30 seconds after the custom code is displayed, the system returns to the original clock indicator. In this case, start again from step 1.
- The air conditioner custom code is set to A prior to shipment. To change the custom code, contact your retailer.
- If you do not know the assigned code for the air conditioner, try each of the custom code ($\text{A} \rightarrow \text{b} \rightarrow \text{c} \rightarrow \text{d}$) until you find the code which operates the air conditioner.

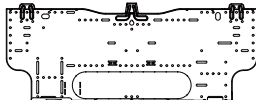
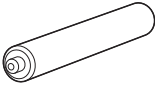

12. Accessories

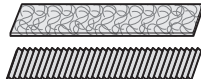
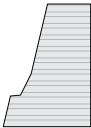
12-1. Models: ASYG07KETE, ASYG09KETE, ASYG12KETE, ASYG14KETE, ASYG07KETE-B, ASYG09KETE-B, ASYG12KETE-B, and ASYG14KETE-B

Part name	Exterior	Q'ty	Part name	Exterior	Q'ty
Operating manual		1	Cloth tape		1
Operating manual (CD-ROM)		1	Tapping screw (large)		5
Installation manual		1	Tapping screw (small)		2
Remote controller		1	Wall hook bracket		1
Battery		2	Filter holder		2
Remote controller holder		1	Air cleaning filters		1
Template (for pipe cover cutting)		1			

13. Optional parts

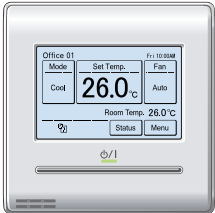
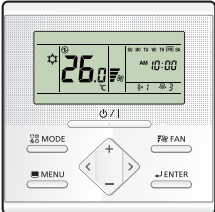

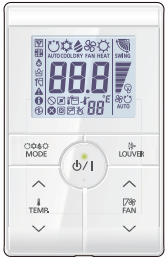
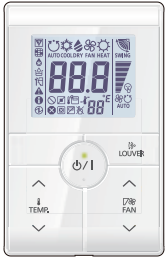



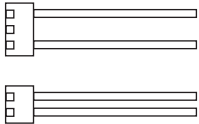
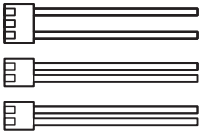

13-1. Controllers

Exterior	Part name	Model name	Summary
	Wired remote controller	UTY-RNRYZ*	Easy finger touch operation with LCD panel. Backlit LCD enables easy operation in a dark room. Wire type: Non-polar 2-wire Optional communication kit is necessary for installation.
	Wired remote controller	UTY-RLRY	High visibility and easy operation. Room temperature can be accurately controlled using the built-in thermo sensor. Wire type: Non-polar 2-wire Optional communication kit is necessary for installation.
	Compact wired remote controller	UTY-RCRYZ1	Compact body and easy operation. Room temperature can be accurately controlled using the built-in thermo sensor. Wire type: Non-polar 2-wire
	Simple remote controller	UTY-RSRY	Compact remote controller concentrates on the basic functions such as Start/Stop, fan control, temperature setting, and operation mode. Wire type: Non-polar 2-wire Optional communication kit is necessary for installation.
	Simple remote controller	UTY-RHRY	Compact remote controller concentrates on the basic functions such as Start/Stop, fan control, and temperature setting. Wire type: Non-polar 2-wire Optional communication kit is necessary for installation.

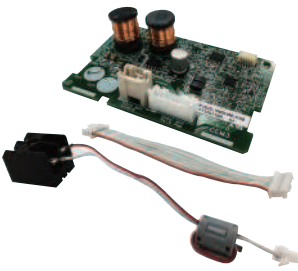
NOTES:

- Available functions may differ by the remote controller. For details, refer to the operation manual.
- When using the group controlling system of the wired remote controller, using Wireless LAN adapter is prohibited.

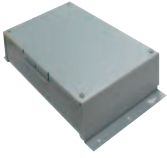
13-2. Others

Exterior	Part name	Model name	Summary
	External connect kit	UTY-XWZX	Use to connect with various peripheral devices and air conditioner PCB.
	External connect kit	UTY-XWZXZ5	Required when external device is connected.
	External input and output PCB	UTY-XCSXZ2	Use to connect with external devices and air conditioner PCB. Optional External connect kit is necessary for installation.
	Communication kit	UTY-TWRXZ2	Use to connect Non-polar 2-core wired remote controller.
	Wireless LAN adapter	UTY-TFSXF2	Remotely manage an air conditioning system using mobile devices such as smartphones and tablets. Appropriate application for each region is required to use this option. For details, contact FGL sales company.
	Modbus converter	UTY-VMSX	For connection between indoor unit with UART interface and a Modbus open network.
	KNX converter	UTY-VKSX	For connection between indoor unit with UART interface and a KNX open network.
	Network converter	UTY-VTGX	This converter is required when connecting single split system to VRF network system.
	Network converter (AC power supply)	UTY-VTGXV	This converter is required when connecting single split system to VRF network system.
	External switch controller	UTY-TERX	Air conditioner switching can be controlled by connecting other external sensor switches.

Part 2. OUTDOOR UNIT

SINGLE TYPE:

AOYG07KETA

AOYG09KETA

AOYG12KETA

AOYG14KETA

1. Specifications

OUTDOOR UNIT
AOYG07-14KETA

OUTDOOR UNIT
AOYG07-14KETA

Type			Inverter heat pump				
Model name			AOYG07KETA	AOYG09KETA	AOYG12KETA	AOYG14KETA	
Power supply			230 V ~ 50 Hz				
Available voltage range			198—264 V				
Starting current			A	3.0	3.4	5.1	6.8
Fan	Airflow rate	Cooling	m ³ /h	1,650	1,650	1,700	1,680
		Heating		1,450	1,450	1,470	1,580
	Type × Q'ty	Propeller fan × 1					
Motor output			W	23			
Sound pressure level *1	Cooling	Heating	dB (A)	46		50	
				46		50	
Sound power level	Cooling	Heating	dB (A)	61		65	
				61		65	
Heat exchanger type	Dimensions (H × W × D)	mm	504 × 650 × 18.2		504 × 630 × 36.4		504 × 881 × 36.4
	Fin pitch		1.3				
	Rows × Stages	1 × 24		2 × 24			
	Pipe type	Copper					
	Fin type	Type (Material)	Corrugate (Aluminum)				
		Surface treatment	PC Fin				
Compressor	Type	DC rotary					
	Motor output	W	550		900		
Refrigerant	Type (Global warming potential)	R32 (675)					
	Charge	g	600		700		850
Refrigerant oil	Type	RB74AF					
	Amount	cm ³	240				340
Enclosure	Material	Steel sheet					
	Color	Beige					
Dimensions (H × W × D)	Net	mm	541 × 663 × 290		542 × 799 × 290		
	Gross		602 × 804 × 375		602 × 940 × 375		
Weight	Net	kg	23		25		31
	Gross		26		29		35
Connection pipe	Size	Liquid	mm (in)	Ø 6.35 (Ø 1/4)			
		Gas		Ø 9.52 (Ø 3/8)			
	Method	Flare					
	Pre-charge length	m	15				
	Max. length		20				
Max. height difference	15						
Operation range	Cooling	°C	-10 to 46				
	Heating		-15 to 24				
Drain hose	Material	PP+LLDPE					
	Size	mm	Ø 13.0 (I. D.), Ø 16.0 to Ø 16.8 (O. D.)				
NOTES:							
<ul style="list-style-type: none"> • Specifications are based on the following conditions: <ul style="list-style-type: none"> – Cooling: Indoor temperature of 27 °CDB/19 °CWB, and outdoor temperature of 35 °CDB/24 °CWB. – Heating: Indoor temperature of 20 °CDB/15 °CWB, and outdoor temperature of 7 °CDB/6 °CWB. – Pipe length: 5 m, Height difference: 0 m. • Protective function might work when using it outside the operation range. • *1: Sound pressure level <ul style="list-style-type: none"> – Measured values in manufacturer's anechoic chamber. – Because of the surrounding sound environment, the sound levels measured in actual installation conditions might be higher than the specified values here. • This data is based on EN 14511 standard. 							

2. Dimensions

2-1. Models: AOYG07KETA, AOYG09KETA, and AOYG12KETA

Unit: mm

OUTDOOR UNIT
AOYG07-14KETA

OUTDOOR UNIT
AOYG07-14KETA

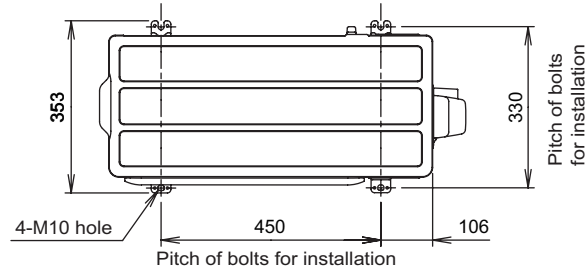

Top view

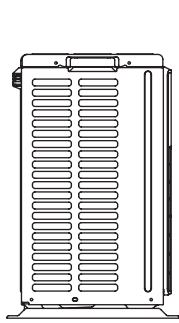

Side view

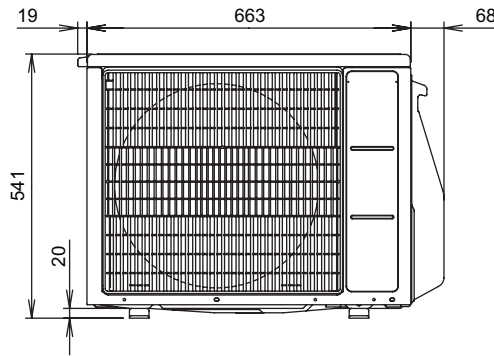

Front view

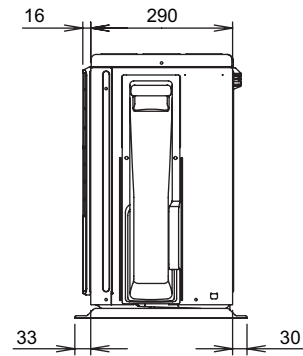

Side view

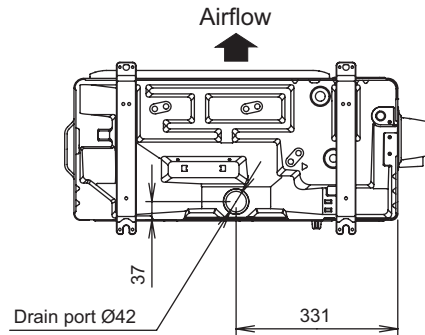

Bottom view

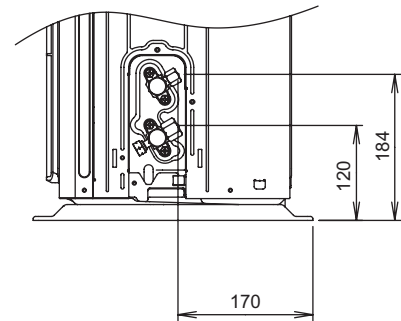

Side view (Valve part)

2-2. Model: AOYG14KETA

Unit: mm

OUTDOOR UNIT
AOYG07-14KETA

OUTDOOR UNIT
AOYG07-14KETA

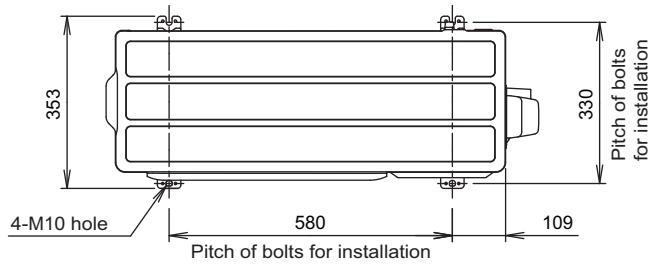

Top view

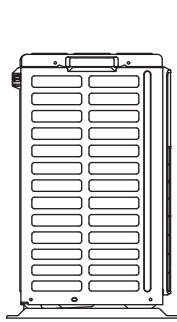

Side view

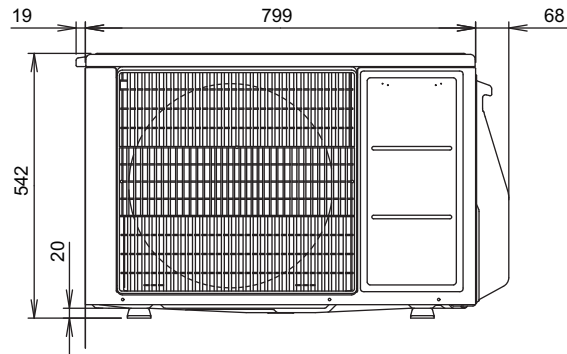

Front view

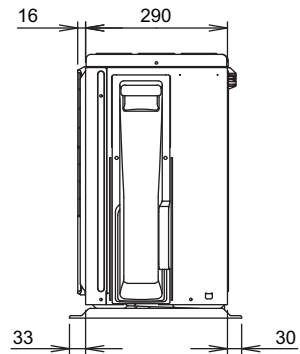

Side view

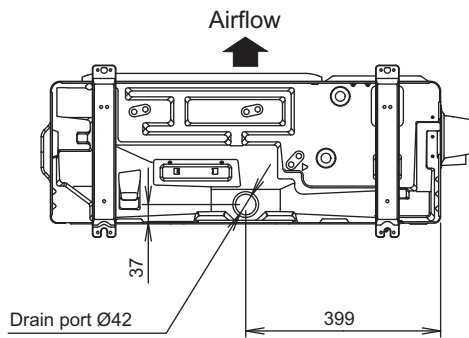

Bottom view

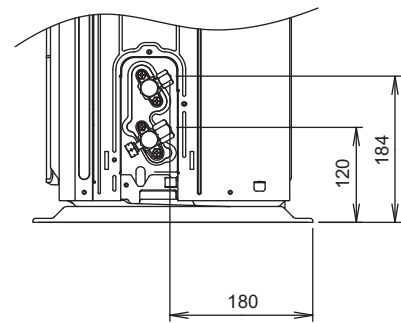

Side view (Valve part)

3. Installation space

3-1. Models: AOYG07KETA, AOYG09KETA, AOYG12KETA, and AOYG14KETA

■ Space requirement

Provide sufficient installation space for product safety.

⚠ CAUTION

Keep the space shown in the installation examples.

If the installation is not performed accordingly, it could cause a short circuit and result in a lack of operating performance.

● Single outdoor unit installation

- When the upper space is open:

Unit: mm

Obstacles at rear only

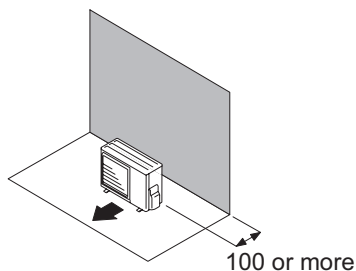

Obstacles at rear and sides

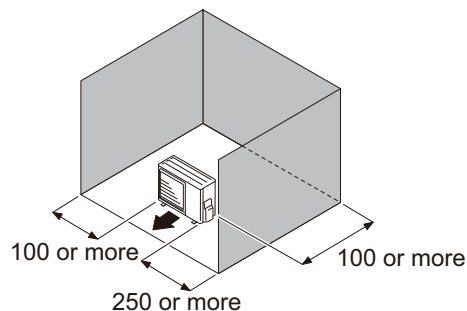

Obstacles at front

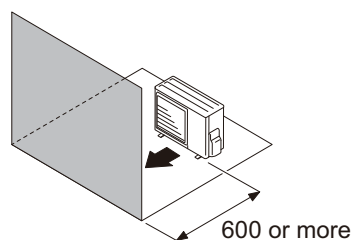

Obstacles at front and rear

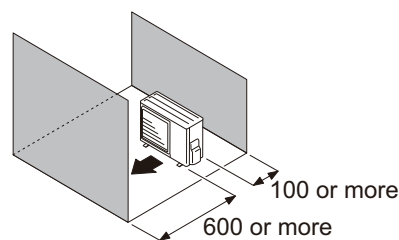

- When an obstruction in the upper space:

Unit: mm

Obstacles at rear and above

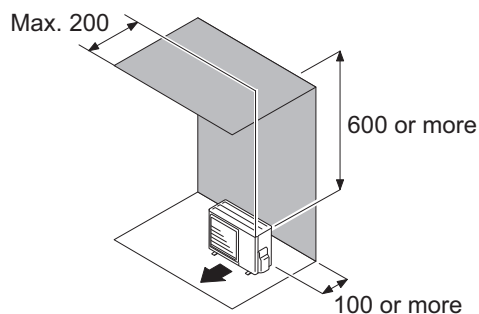

Obstacles at rear, sides, and above

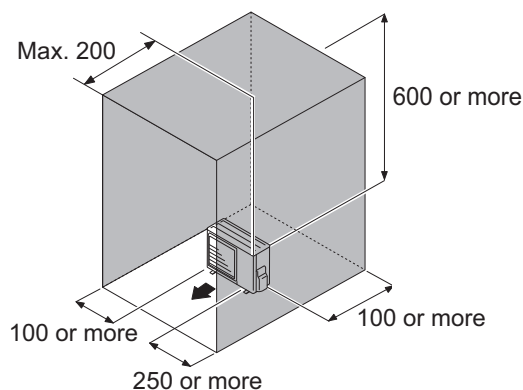

● Multiple outdoor unit installation

- Provide at least 250 mm of space between the outdoor units if multiple units are installed.
- When routing the piping from the side of an outdoor unit, provide space for piping.
- No more than 3 units must be installed side by side.
When 4 units or more are arranged in a line, provide the space as shown in the following example **“When an obstruction in the upper space:”**.

- **When the upper space is open:**

Unit: mm

Obstacles at rear only

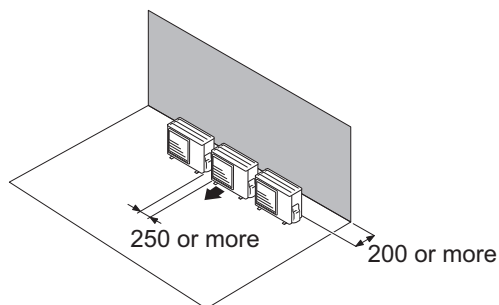

Obstacles at front only

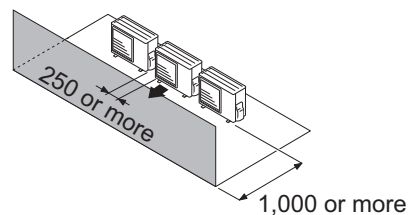

Obstacles at front and rear

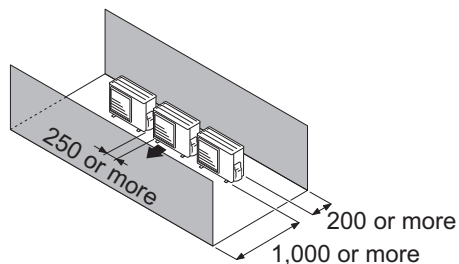

- **When an obstruction in the upper space:**

Unit: mm

Obstacles at rear and above.

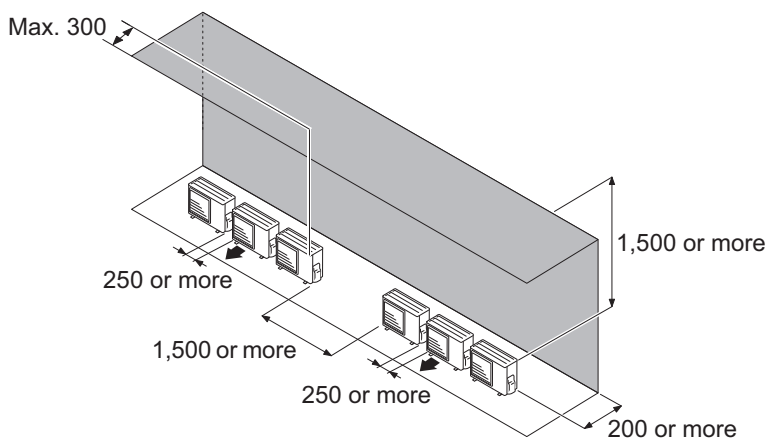

● Outdoor units installation in multi-row

Unit: mm

Single parallel unit arrangement

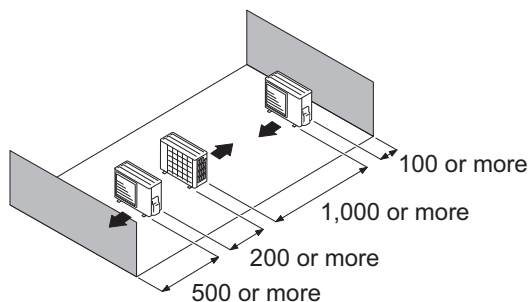

Multiple parallel unit arrangement

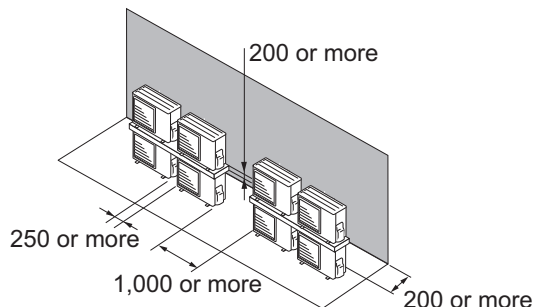
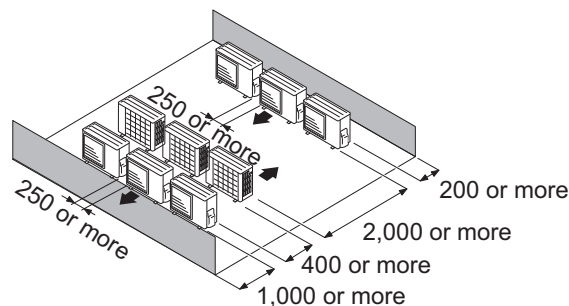

NOTES:

- If the space is larger than stated above, the condition will be the same as when there is no obstacle.
- When installing the outdoor unit, be sure to open the front and left side to obtain better operation efficiency.

⚠ CAUTION

- Do not install the outdoor unit in two-stage where the drain water could freeze. Otherwise the drainage from the upper unit may form ice and cause a malfunction of the lower unit.
- When the outdoor temperature is 0 °C or less, do not use the accessory drain pipe and drain cap. If the drain pipe and drain cap are used, the drain water in the pipe may freeze in extremely cold climate. (For reverse cycle model only.)
- In area with heavy snowfall, if the inlet and outlet of the outdoor unit is blocked with snow, it might become difficult to get warm, and it is likely to cause product malfunction. Construct a canopy and a pedestal, or place the unit on a high stand that is locally installed.

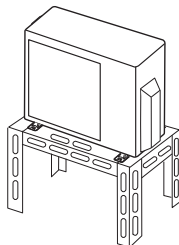

4. Refrigerant circuit

4-1. Models: AOYG07KETA, AOYG09KETA, and AOYG12KETA

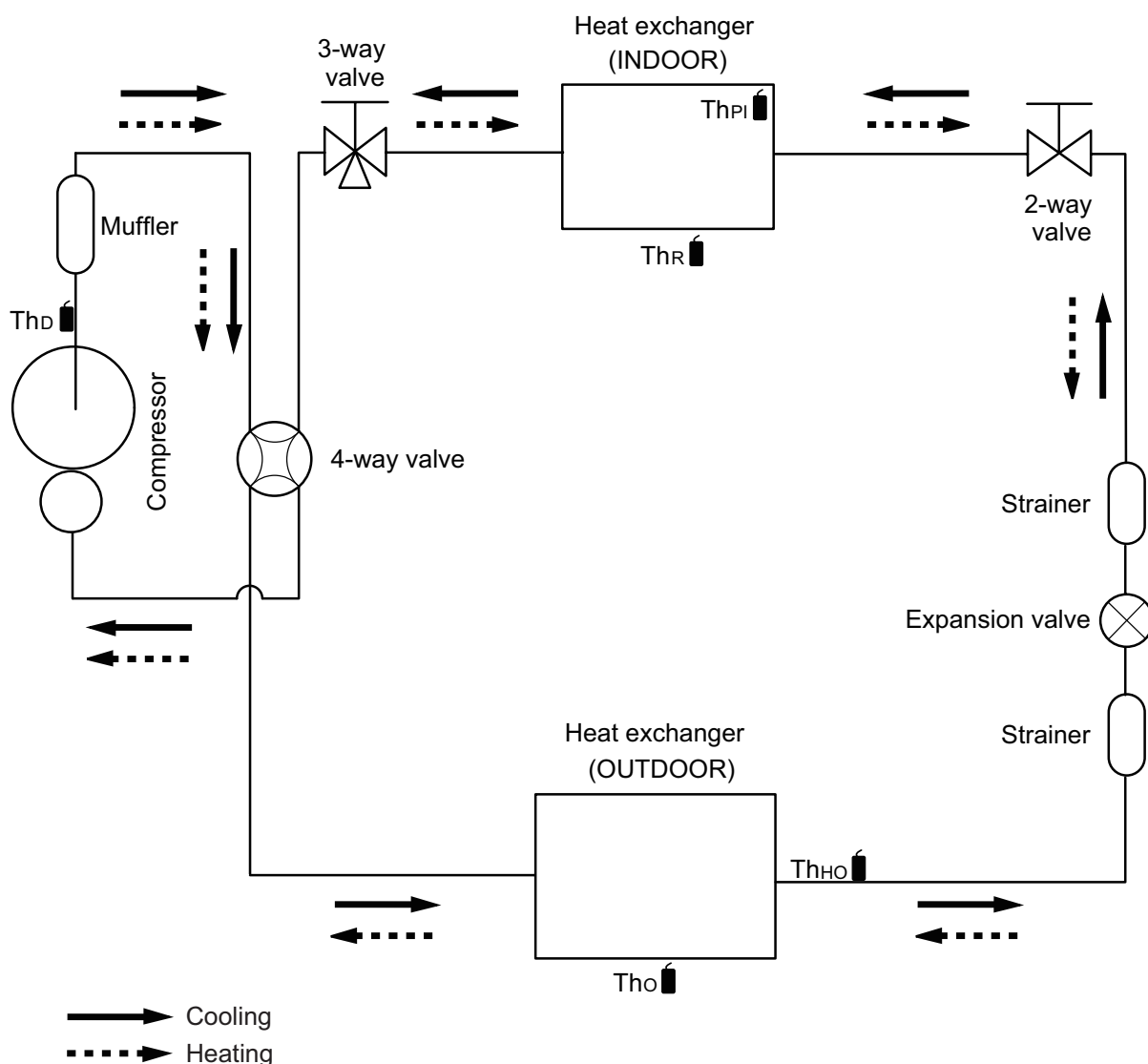

Th_D : Thermistor (Discharge temperature)

Th_O : Thermistor (Outdoor temperature)

Th_{HO} : Thermistor (Heat exchanger out temperature)

Th_R : Thermistor (Room temperature)

Th_{PI} : Thermistor (Pipe temperature)

4-2. Model: AOYG14KETA

OUTDOOR UNIT
AOYG07-14KETA

OUTDOOR UNIT
AOYG07-14KETA

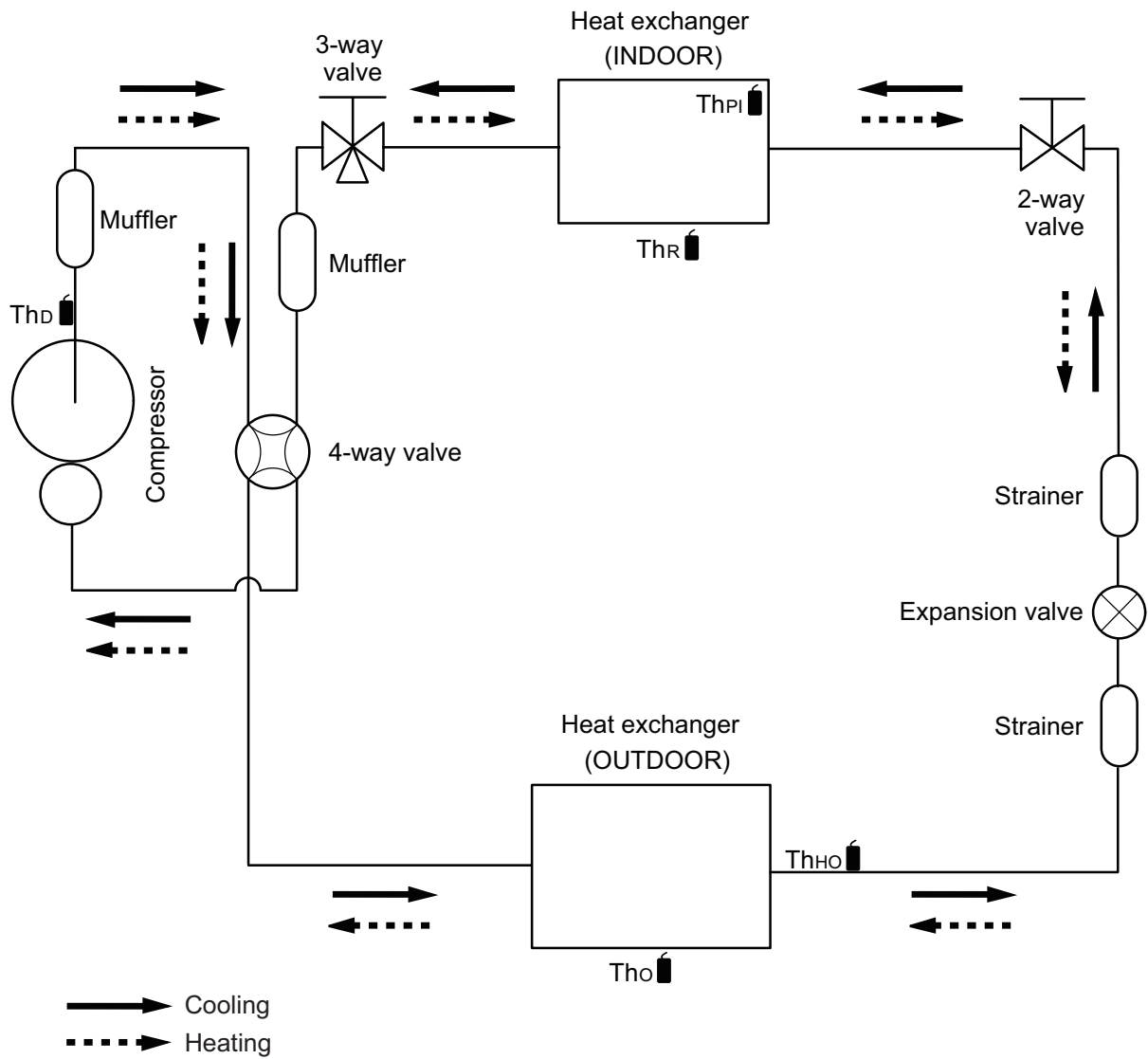

- Th_D : Thermistor (Discharge temperature)
- Th_O : Thermistor (Outdoor temperature)
- Th_{HO} : Thermistor (Heat exchanger out temperature)
- Th_R : Thermistor (Room temperature)
- Th_{PI} : Thermistor (Pipe temperature)

5. Wiring diagrams

5-1. Models: AOYG07KETA, AOYG09KETA, AOYG12KETA, and AOYG14KETA

OUTDOOR UNIT
AOYG07-14KETA

OUTDOOR UNIT
AOYG07-14KETA

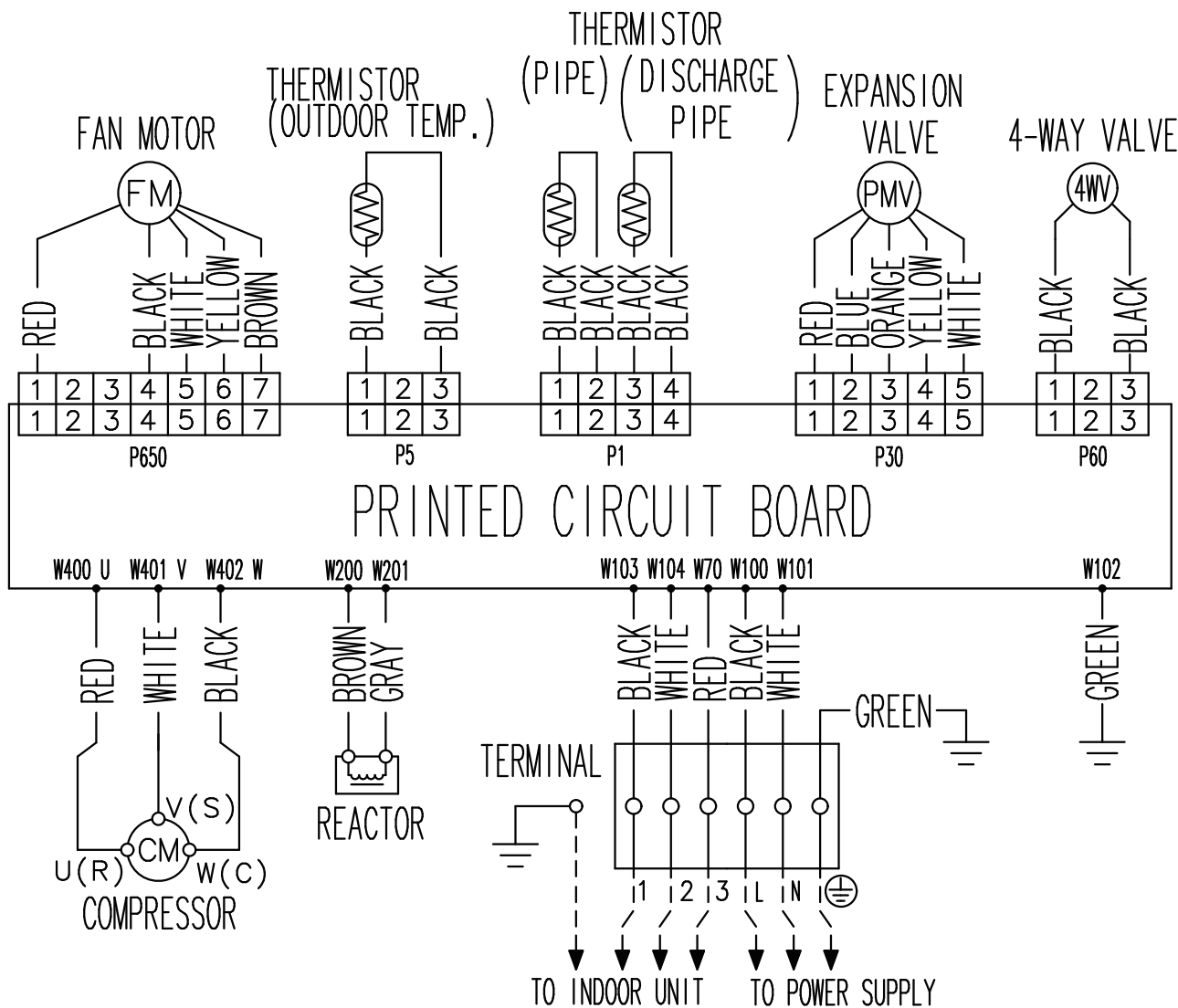

6. Capacity compensation rate for pipe length and height difference

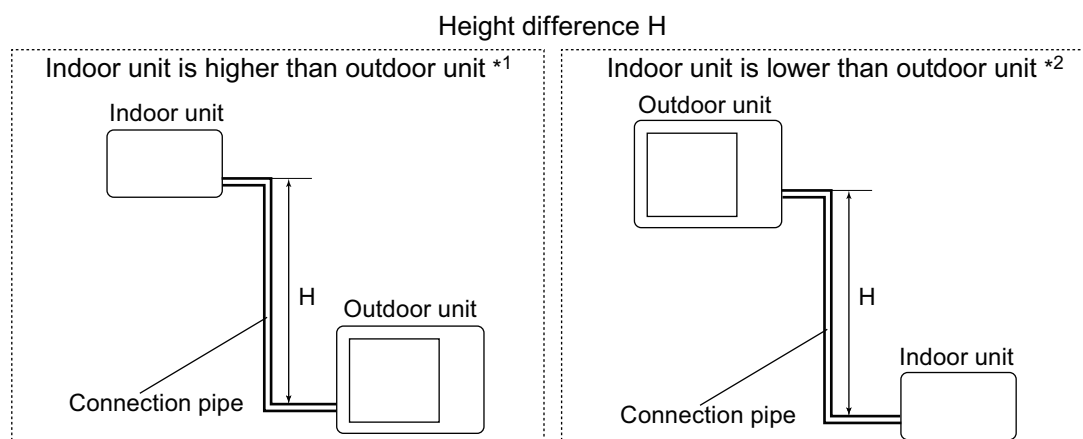

6-1. Models: AOYG07KETA and AOYG09KETA

NOTE: Values mentioned in the table are calculated based on the maximum capacity.

COOLING			Pipe length (m)				
			5	7.5	10	15	20
Height difference H (m)	Indoor unit is higher than outdoor unit *1	15	—	—	—	0.872	0.910
		10	—	—	0.961	0.886	0.925
		7.5	—	0.979	0.965	0.890	0.929
		5	0.992	0.983	0.969	0.893	0.933
	Indoor unit is lower than outdoor unit *2	0	1.000	0.991	0.976	0.901	0.940
		-5	1.000	0.991	0.976	0.901	0.940
		-7.5	—	0.991	0.976	0.901	0.940
		-10	—	—	0.976	0.901	0.940
		-15	—	—	—	0.901	0.940

HEATING			Pipe length (m)				
			5	7.5	10	15	20
Height difference H (m)	Indoor unit is higher than outdoor unit *1	15	—	—	—	0.832	0.822
		10	—	—	0.917	0.832	0.822
		7.5	—	0.961	0.917	0.832	0.822
		5	1.000	0.961	0.917	0.832	0.822
	Indoor unit is lower than outdoor unit *2	0	1.000	0.961	0.917	0.832	0.822
		-5	0.955	0.956	0.912	0.828	0.818
		-7.5	—	0.954	0.910	0.826	0.816
		-10	—	—	0.908	0.824	0.814
		-15	—	—	—	0.815	0.805

6-2. Model: AOYG12KETA

NOTE: Values mentioned in the table are calculated based on the maximum capacity.

COOLING			Pipe length (m)				
			5	7.5	10	15	20
Height difference H (m)	Indoor unit is higher than outdoor unit *1	15	—	—	—	0.858	0.868
		10	—	—	0.929	0.872	0.882
		7.5	—	0.960	0.933	0.876	0.885
		5	0.992	0.964	0.937	0.879	0.889
	Indoor unit is lower than outdoor unit *2	0	1.000	0.972	0.944	0.887	0.896
		-5	1.000	0.972	0.944	0.887	0.896
		-7.5	—	0.972	0.944	0.887	0.896
		-10	—	—	0.944	0.887	0.896
		-15	—	—	—	0.887	0.896

HEATING			Pipe length (m)				
			5	7.5	10	15	20
Height difference H (m)	Indoor unit is higher than outdoor unit *1	15	—	—	—	0.896	0.879
		10	—	—	0.968	0.890	0.879
		7.5	—	0.994	0.968	0.896	0.879
		5	1.000	0.994	0.968	0.896	0.879
	Indoor unit is lower than outdoor unit *2	0	1.000	0.994	0.968	0.896	0.879
		-5	0.995	0.989	0.963	0.891	0.875
		-7.5	—	0.987	0.961	0.889	0.873
		-10	—	—	0.959	0.887	0.871
		-15	—	—	—	0.878	0.862

6-3. Model: AOYG14KETA

NOTE: Values mentioned in the table are calculated based on the maximum capacity.

COOLING			Pipe length (m)				
			5	7.5	10	15	20
Height difference H (m)	Indoor unit is higher than outdoor unit *1	15	—	—	—	0.893	0.909
		10	—	—	0.955	0.908	0.924
		7.5	—	0.975	0.959	0.912	0.928
		5	0.992	0.979	0.963	0.916	0.931
	Indoor unit is lower than outdoor unit *2	0	1.000	0.987	0.970	0.923	0.939
		-5	1.000	0.987	0.970	0.923	0.939
		-7.5	—	0.987	0.970	0.923	0.939
		-10	—	—	0.970	0.923	0.939
		-15	—	—	—	0.923	0.939

HEATING			Pipe length (m)				
			5	7.5	10	15	20
Height difference H (m)	Indoor unit is higher than outdoor unit *1	15	—	—	—	0.956	0.938
		10	—	—	1.004	0.956	0.938
		7.5	—	1.013	1.004	0.956	0.938
		5	1.000	1.013	1.004	0.956	0.938
	Indoor unit is lower than outdoor unit *2	0	1.000	1.013	1.004	0.956	0.938
		-5	0.995	1.008	0.999	0.951	0.938
		-7.5	—	1.005	0.997	0.948	0.931
		-10	—	—	0.994	0.946	0.929
		-15	—	—	—	0.937	0.919

7. Additional charge calculation

7-1. Models: AOYG07KETA and AOYG09KETA

Refrigerant type		R32
Refrigerant amount	g	600

■ Refrigerant charge

Total pipe length	m	15 or less	20 (Max.)	20 g/m
Additional charge	g	0	100	

7-2. Model: AOYG12KETA

Refrigerant type		R32
Refrigerant amount	g	700

■ Refrigerant charge

Total pipe length	m	15 or less	20 (Max.)	20 g/m
Additional charge	g	0	100	

7-3. Model: AOYG14KETA

Refrigerant type		R32
Refrigerant amount	g	850

■ Refrigerant charge

Total pipe length	m	15 or less	20 (Max.)	20 g/m
Additional charge	g	0	100	

8. Airflow

8-1. Model: AOYG07KETA

● Cooling

m ³ /h	1,650
l/s	458
CFM	971

● Heating

m ³ /h	1,450
l/s	403
CFM	853

8-2. Model: AOYG09KETA

● Cooling

m ³ /h	1,650
l/s	458
CFM	971

● Heating

m ³ /h	1,450
l/s	403
CFM	853

8-3. Model: AOYG12KETA

● Cooling

m ³ /h	1,700
l/s	472
CFM	1,001

● Heating

m ³ /h	1,470
l/s	408
CFM	865

8-4. Model: AOYG14KETA

● Cooling

m ³ /h	1,680
l/s	467
CFM	989

● Heating

m ³ /h	1,580
l/s	439
CFM	930

9. Operation noise (sound pressure)

9-1. Noise level curve

Model: AOYG07KETA

Cooling

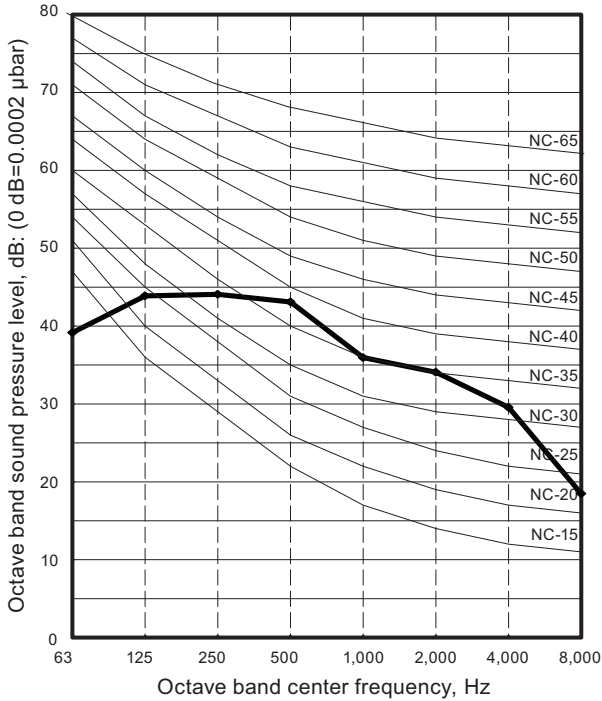

Heating

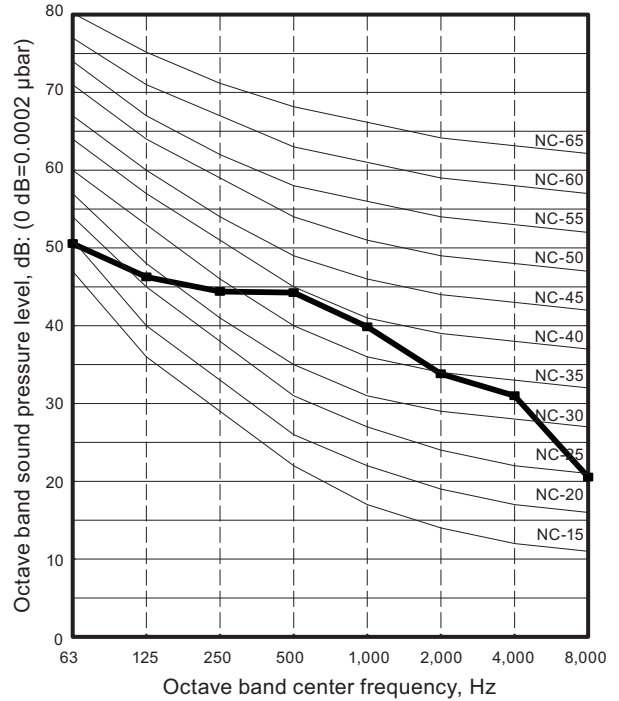

Model: AOYG09KETA

Cooling

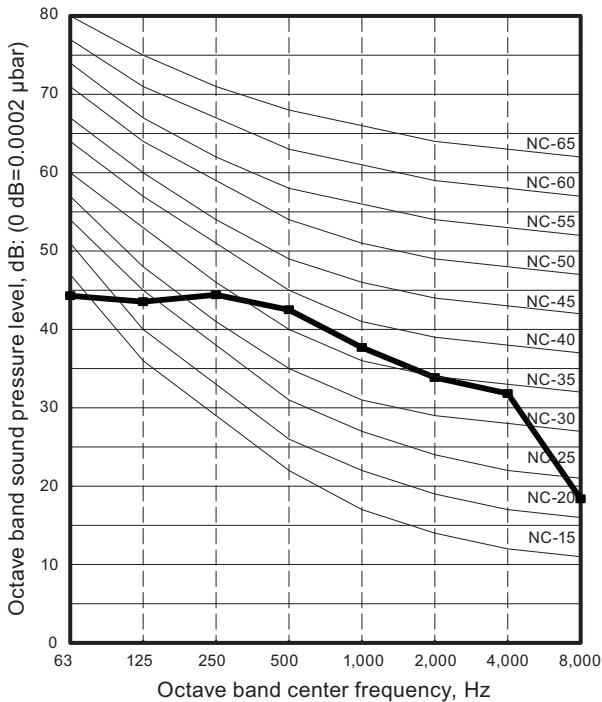

Heating

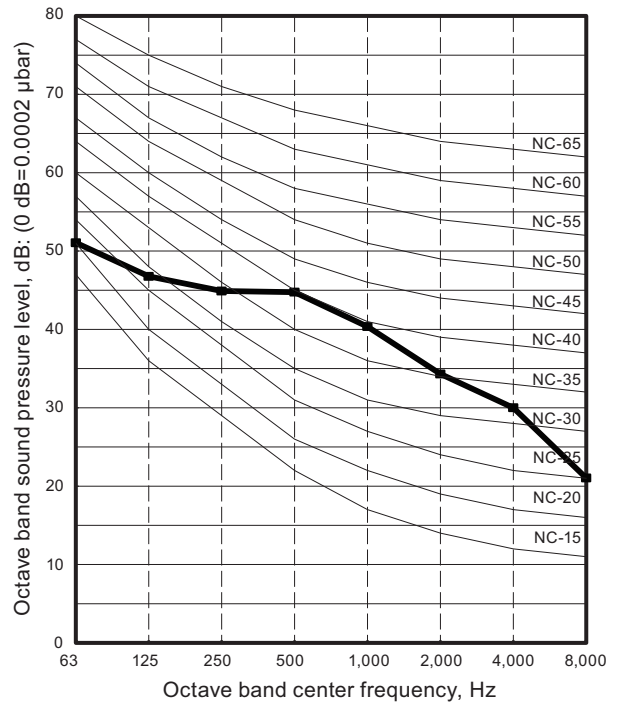

OUTDOOR UNIT
AOYG07-14KETA

OUTDOOR UNIT
AOYG07-14KETA

Model: AOYG12KETA

Cooling

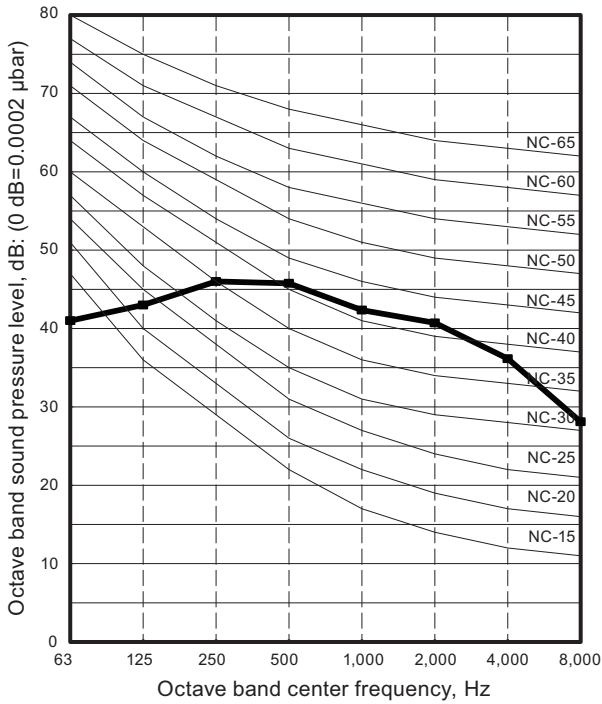

Heating

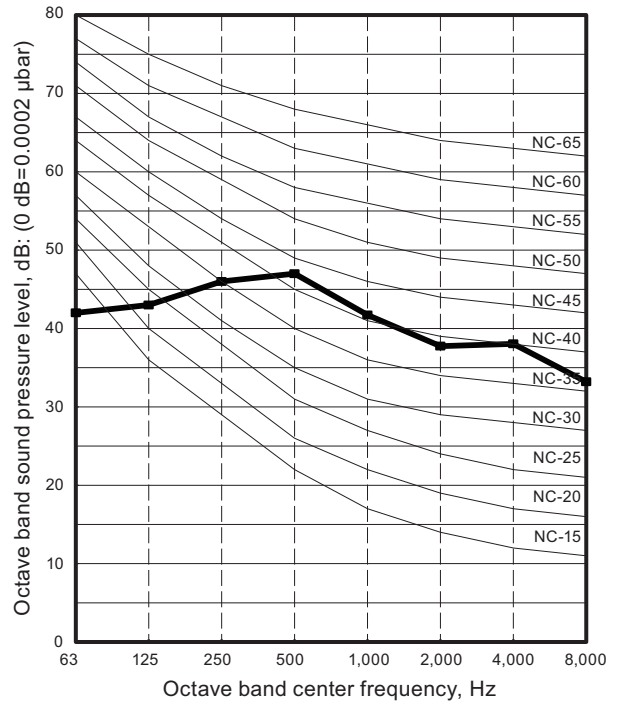

OUTDOOR UNIT
AOYG07-14KETA

OUTDOOR UNIT
AOYG07-14KETA

Model: AOYG14KETA

Cooling

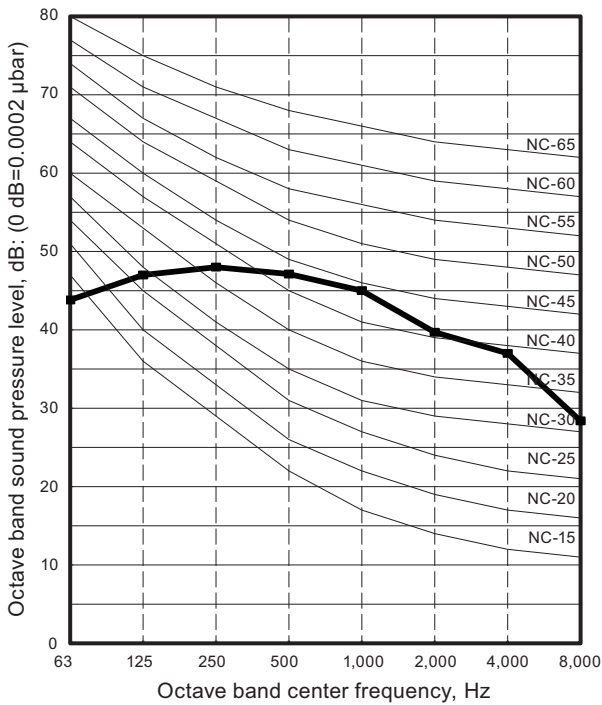

Heating

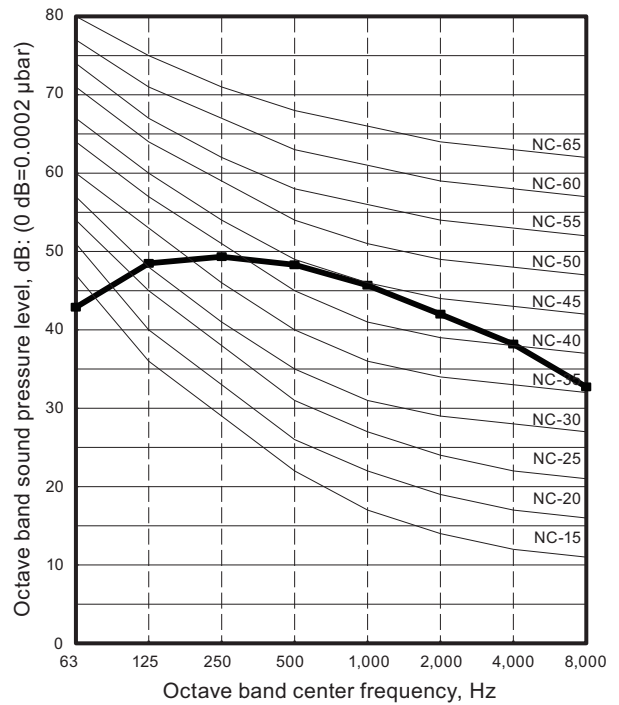

9-2. Sound level check point

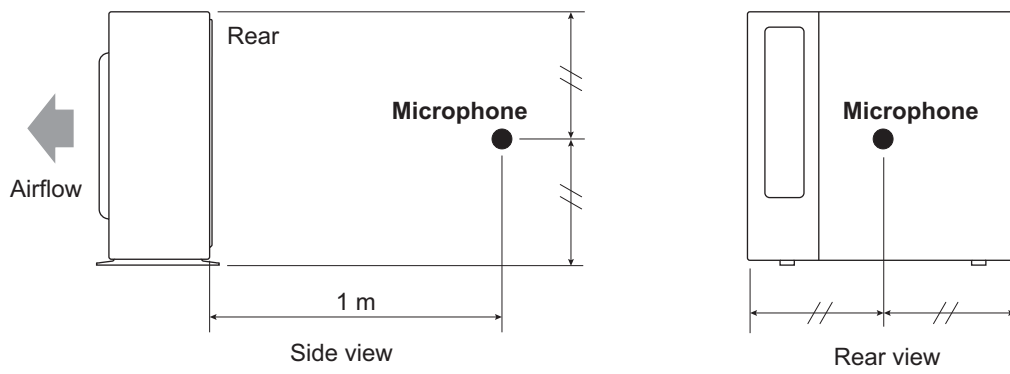

NOTE: Detailed shape of the actual outdoor unit might be slightly different from the one illustrated above.

10. Electrical characteristics

Model name			AOYG07KETA	AOYG09KETA	AOYG12KETA	AOYG14KETA
Power supply	Voltage	V	230 ~			
	Frequency	Hz	50			
Max operating current *1		A	9.0			
Starting current		A	3.0	3.4	5.1	6.8
Wiring spec. *2	Circuit breaker current		A	15		
	Power cable		mm ²	1.5		
	Connection cable *3	Cross-sectional area	mm ²	1.5		
		Limited wiring length	m	21		

*1: Maximum operating current is the total current of the indoor unit and the outdoor unit.

*2: Selected sample based on Japan Electrotechnical Standards and Codes Committee E0005. As the regulations of wire size and circuit breaker differ in each country or region, select appropriate devices complied to the regional standard.

*3: Limit voltage drop to less than 2%. If voltage drop is 2% or more, increase cable conductor size.

11. Safety devices

OUTDOOR UNIT
AOYG07-14KETA

OUTDOOR UNIT
AOYG07-14KETA

Type of protection	Protection form		Model	
			AOYG07KETA	AOYG09KETA
Circuit protection	Current fuse (Main PCB)		250 V, 20 A	
			250 V, 5 A	
Fan motor protection	Terminal protection program	Activate	85—122 °C Fan motor stop	
		Reset	77—114 °C Fan motor restart	
Compressor protection	Terminal protection program (Discharge temp.)	Activate	110 °C Compressor stop	
		Reset	After 7 minutes Compressor restart	

Type of protection	Protection form		Model	
			AOYG12KETA	AOYG14KETA
Circuit protection	Current fuse (Main PCB)		250 V, 20 A	
			250 V, 5 A	
Fan motor protection	Terminal protection program	Activate	85—122 °C Fan motor stop	
		Reset	77—114 °C Fan motor restart	
Compressor protection	Terminal protection program (Discharge temp.)	Activate	110 °C Compressor stop	
		Reset	After 7 minutes Compressor restart	

12. Accessories

12-1. Models: AOYG07KETA, AOYG09KETA, AOYG12KETA, and AOYG14KETA

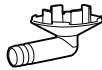
Part name	Exterior	Q'ty	Part name	Exterior	Q'ty
Installation manual		1	Drain pipe		1