

**SPLIT TYPE  
ROOM AIR CONDITIONER  
WALL MOUNTED<sup>type</sup>  
INVERTER**

# **SERVICE INSTRUCTION**



<b>Models</b>	<b>Indoor unit</b>	<b>Outdoor unit</b>
	AS*G09KXCA	AO*G09KXCA
	AS*G12KXCA	AO*G12KXCA

# CONTENTS

## 1. DESCRIPTION OF EACH CONTROL OPERATION

1. COOLING OPERATION.....	01-01
2. HEATING OPERATION.....	01-02
3. DRY OPERATION.....	01-02
4. AUTO CHANGEOVER OPERATION.....	01-03
5. INDOOR FAN CONTROL.....	01-05
6. OUTDOOR FAN CONTROL.....	01-07
7. LOUVER CONTROL.....	01-08
8. DUAL FAN CONTROL.....	01-09
9. COMPRESSOR CONTROL.....	01-10
10. TIMER OPERATION CONTROL.....	01-11
11. ELECTRONIC EXPANSION VALVE CONTROL.....	01-13
12. TEST OPERATION CONTROL.....	01-13
13. PREVENT TO RESTART (ST).....	01-13
14. FOUR-WAY VALVE EXTENSION SELECT.....	01-14
15. AUTO RESTART.....	01-14
16. FORCED AUTO OPERATION.....	01-14
17. FORCED COOLING OPERATION.....	01-14
18. COMPRESSOR PREHEATING.....	01-15
19. 10°C HEAT OPERATION.....	01-15
20. ECONOMY OPERATION.....	01-15
21. DEFROST OPERATION CONTROL.....	01-16
22. OFF DEFROST OPERATION CONTROL.....	01-18
23. VARIOUS PROTECTIONS.....	01-19
24. LOW NOISE OPERATION.....	01-21
25. HUMAN SENSOR (Energy Saving).....	01-21
26. POWERFUL OPERATION.....	01-22
27. FILTER CLEAN.....	01-22
28. PLASMA CLEAN .....	01-22
29. WIRELESS LAN .....	01-23

## 2. TROUBLE SHOOTING

2-1 INDOOR UNIT ERROR DISPLAY.....	02-01
2-2 WIRELESS LAN ADAPTER ERROR DISPLAY.....	02-02
2-3 MOBILE APP ERROR DISPLAY.....	02-03
2-4 MOBILE APP ERROR DISPLAY (In Wireless LAN Control system).....	02-04
2-5 TROUBLE SHOOTING WITH ERROR CODE.....	02-05
2-6 TROUBLE SHOOTING WITH NO ERROR CODE.....	02-38
2-7 SERVICE PARTS INFORMATION.....	02-43

# CONTENTS

## **3. APPENDING DATA**

3. FUNCTION SETTING.....	03-01
3-1 FUNCTION SETTING.....	03-01
3-2 CUSTOM CODE SETTING FOR WIRELESS REMOTE CONTROLLER.....	03-05
3-3 SWITCHING THE TEMPERATURE UNIT OF REMOTECONTROLLER.....	03-06
4. WIRING DIAGRAMS.....	03-07

# ***WALL MOUNTED type INVERTER***

1 . DESCRIPTION OF EACH  
CONTROL OPERATION

# 1. COOLING OPERATION

## 1-1 COOLING CAPACITY CONTROL

A sensor (room temperature thermistor) built in the indoor unit body will usually perceive difference or variation between a set temperature and present room temperature, and controls the operation frequency of the compressor.

- \* If the room temperature is 6.0°C higher than a set temperature, the compressor operation frequency will attain to maximum performance.
- \* If the room temperature is 1.0°C lower than a set temperature, the compressor will be stopped.
- \* When the room temperature is between +6.0°C to -1.0°C of the setting temperature, the compressor frequency is controlled within the range shown in Table1. However, the maximum frequency is limited in the range shown in Figure1 based on the fan speed mode and the outdoor temperature.

( Table 1 : Compressor Frequency Range )

minimum frequency	maximum frequency I
15rps	63rps

( Fig.1 : Limit of Maximum Frequency based on Outdoor Temperature )

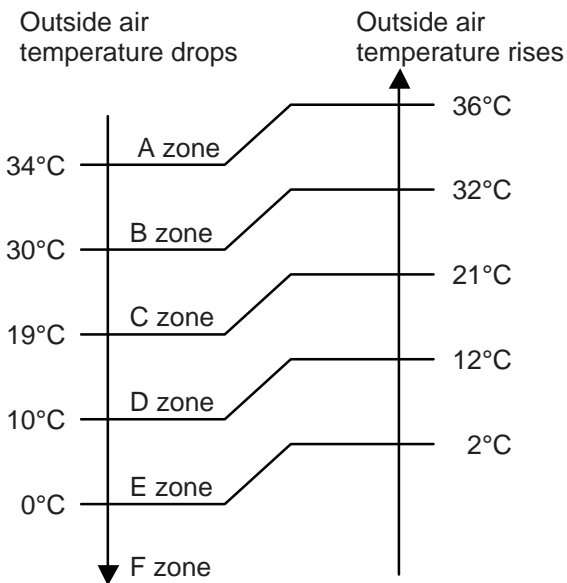

	Hi	Me	Lo	Quiet
A zone	63rps	32rps	26rps	17rps
B zone	63rps	32rps	26rps	17rps
C zone	52rps	32rps	26rps	17rps
D zone	39rps	26rps	22rps	17rps
E zone	39rps	26rps	17rps	15rps
F zone	39rps	26rps	17rps	15rps

## 2. HEATING OPERATION

### 2-1 HEATING CAPACITY CONTROL

A sensor (room temperature thermistor) built in the indoor unit body will usually perceive difference or variation between a set temperature and present room temperature, and controls the operation frequency of the compressor.

- \* If the room temperature is lower by 6.0°C than a set temperature, the compressor operation frequency will attain to maximum performance.
- \* If the room temperature is 1.0°C higher than a set temperature, the compressor will be stopped.
- \* When the room temperature is between +1.0°C to -6.0°C of the setting temperature, the compressor frequency is controlled within the range shown in Table2.

( Table 2 : Compressor Frequency Range )

minimum frequency	maximum frequency
15rps	128rps

## 3. DRY OPERATION

### 3-1 INDOOR UNIT CONTROL

The compressor rotation frequency shall change according to the temperature, set temperature, and room temperature variation which the room temperature sensor of the indoor unit body has detected as shown in the Table3.

( Table3 : Compressor frequency )

	Operating frequency
X zone	22rps
J zone	15rps
Y zone	0rps

( Fig.2 : Compressor Control based on Room Temperature )

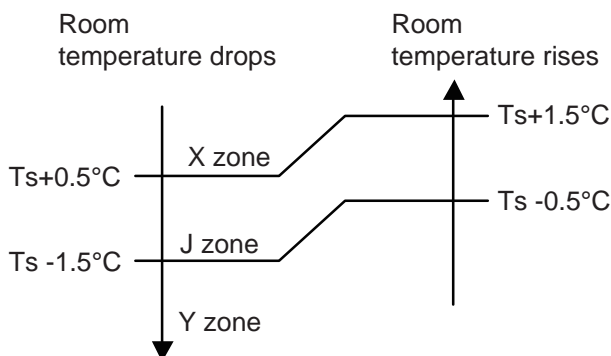

## 4. AUTO CHANGEOVER OPERATION

When the air conditioner is set to the Auto mode by remote controller, operation starts in the optimum mode from among the Heating, Cooling, and Monitoring mode. During operation, the optimum mode is automatically switched in accordance with temperature changes. The temperature can be set between 18°C and 30°C in 1.0°C steps.

- ① When operation starts, indoor main fan and outdoor fan are operated for around 1 minutes. Room temperature and outdoor temperature are sensed, and the operation mode is selected in accordance with the table below. **<Monitoring mode>**

( Table 4 : Operation mode selection table )

Room temperature (TR)	Operation mode
$TR > Ts + 2^{\circ}\text{C}$	Cooling
$Ts + 2^{\circ}\text{C} \geq TR \geq Ts - 2^{\circ}\text{C}$	*Middle zone
$TR < Ts - 2^{\circ}\text{C}$	Heating

TR : Room temperature  
Ts : Setting temperature

\* If it's Middle zone, operation mode of indoor unit is selected as below.

- (1). Selected by the outdoor temperature.

If outdoor unit is operating in other than Cooling and Heating mode, indoor unit will be operated according to the outdoor temperature as below.

( Fig.3 : Outdoor temperature zone selection )

Temperature	Mode
25°C and over	Cooling
25°C under	Heating

- ② When the compressor was stopped for 6 consecutive minutes by the temperature control function after the Cooling or Heating mode was selected at ① above, operation is switched to Monitoring and the operation mode is selected again.
- ③ When the middle zone is selected on the predetermining of the operation mode, the operation mode before the changing to the monitor mode is selected.

■ **AUTO CHANGEOVER** operation flow chart

(Fig.4 Flow chart)

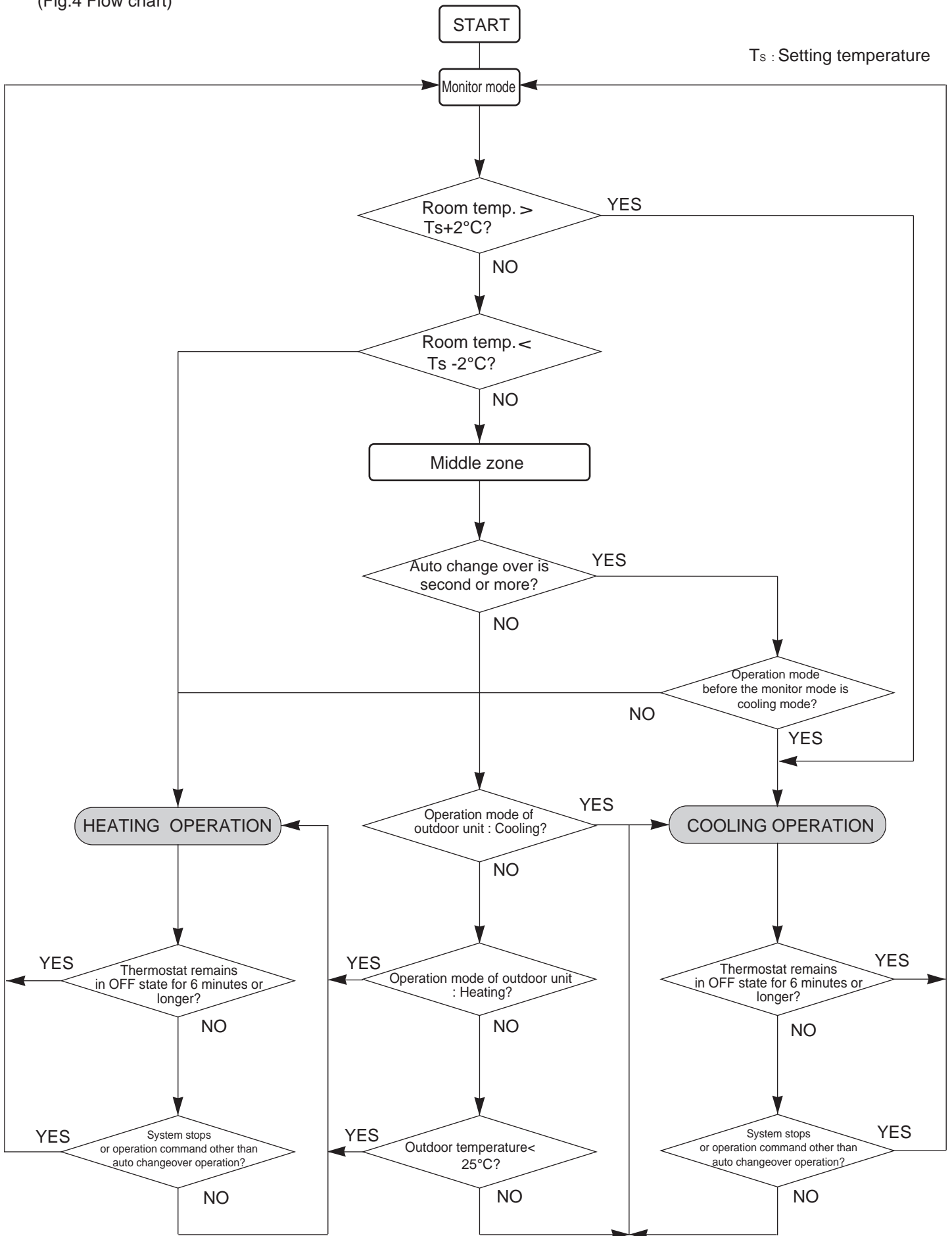



# 5. INDOOR FAN CONTROL

## 1. Fan speed

( Table5 : Indoor Fan Speed )

Main Fan

Operation mode	Air flow mode	Speed (rpm)
Heating	Powerful	1570
	Hi	1490
	Me+	1360
	Me	1300
	Lo	1130
	Lo -	1130
	Quiet	980
	Quiet -	830
	Cool air prevention	830
	S-Lo	610
Cooling/ Fan	Powerful	1390
	Hi	1310
	Me	1160
	Lo	1100
	Lo -	1050
	Quiet	960
	Quiet -	780
Dry	Powerful	1390
	-	X zone : 960 J zone : 720

( Fig 5 : Dual Fan Speed )

Dual Fan(Left Dual Fan)\*

Air flow mode	Speed (rpm)
Powerful	1290
Hi	1070
Me	930
Lo +	800
Lo	800
Quiet +	630
Quiet	630
Cool air prevention	430
Stop	0

\*Right Dual Fan is high +30rpm more than Left Dual Fan.  
(Resonance correspondence)

## 2. FAN OPERATION

The airflow setting by the remote controller can be switched in 5 steps such as AUTO, HIGH, MED, LOW, QUIET while the indoor main fan only runs.

When Fan mode is set at (Auto), it operates on (Me) Fan Speed.

## 3. COOLING OPERATION

Switch the airflow [Auto], and the indoor main fan motor will run according to a room temperature, as shown in Fig. 6.

On the other hand, if switched in [Hi] ~ [Quiet], the indoor main fan motor will run at a constant airflow of [COOL] operation modes Quiet -, Lo -, Me, Hi, as shown in Table5.

( Fig.6 : Airflow change - over ( Cooling : Auto ) )

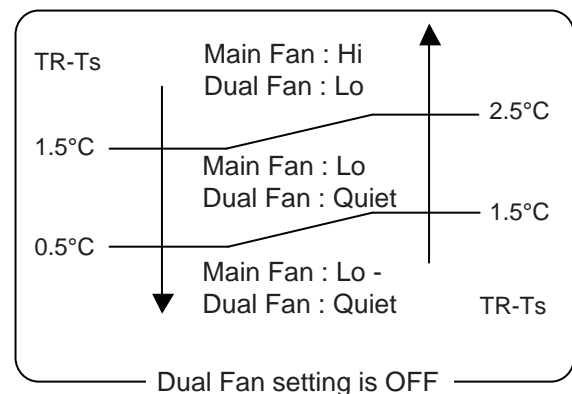
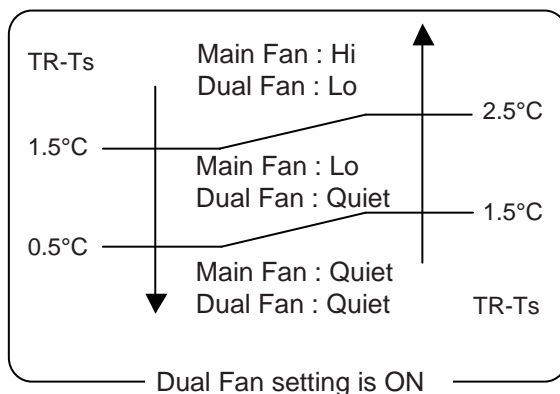

TR : Room temperature  
Ts : Setting temperature

## 4. DRY OPERATION

Refer to the Table5.

During the dry mode operation, the fan speed setting can not be changed.

### 5. HEATING OPERATION

Switch the airflow [AUTO], and the indoor main fan motor will run according to a room temperature, as shown in Fig. 7.

On the other hand, if switched in [Hi] ~ [Quiet], the indoor main fan motor will run at a constant airflow of [HEAT] operation modes Quiet -, Lo -, Me, Hi, as shown in Table5.

( Fig.7 : Airflow change - over ( Heating : Auto ) )

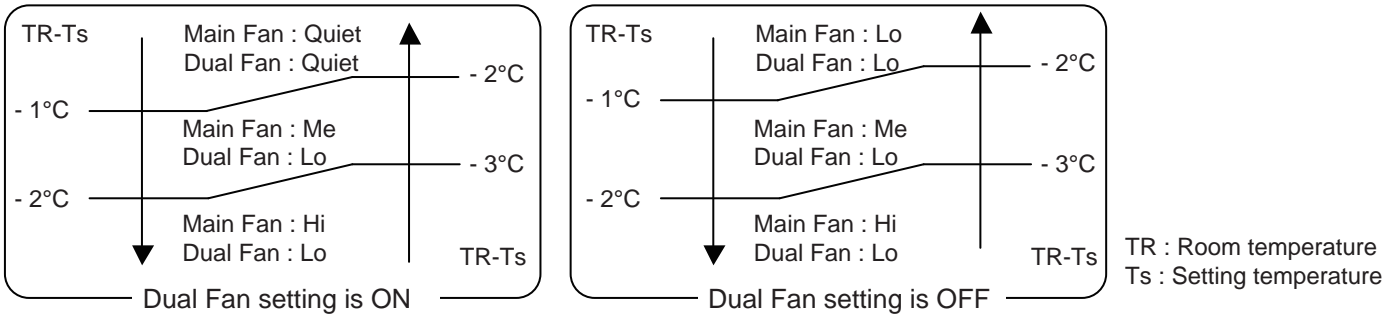

### 6. COOL AIR PREVENTION CONTROL (Heating mode)

The maximum value of the indoor main fan speed is set as shown in Fig. 8, based on the detected temperature by the indoor heat exchanger sensor on heating mode.

(Fig.8 : Cool Air Prevention Control)

#### [Normal operation]

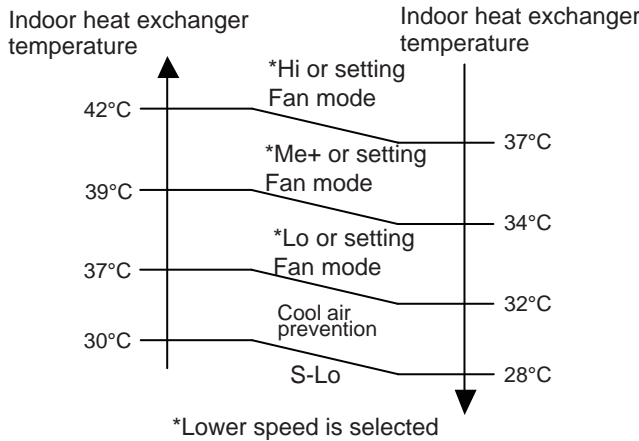

#### [Powerful operation]

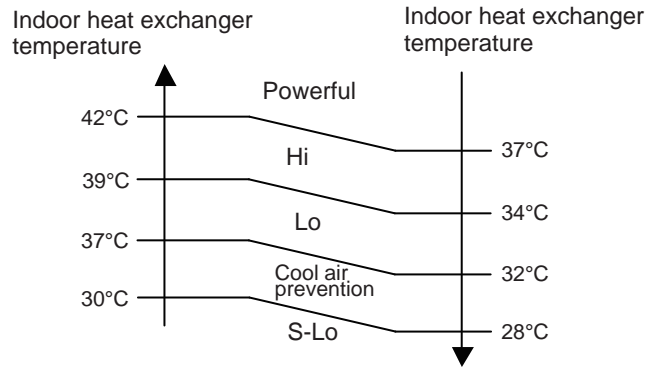

### 7. INDOOR UNIT FAN CONTROL FOR ENERGY SAVING (Cooling mode)

Switch the airflow at cooling mode, and the indoor main fan motor will run as shown in Fig.9. It depends on the Function setting "Indoor unit fan control for energy saving."

( Fig.9 : Indoor Fan Control )

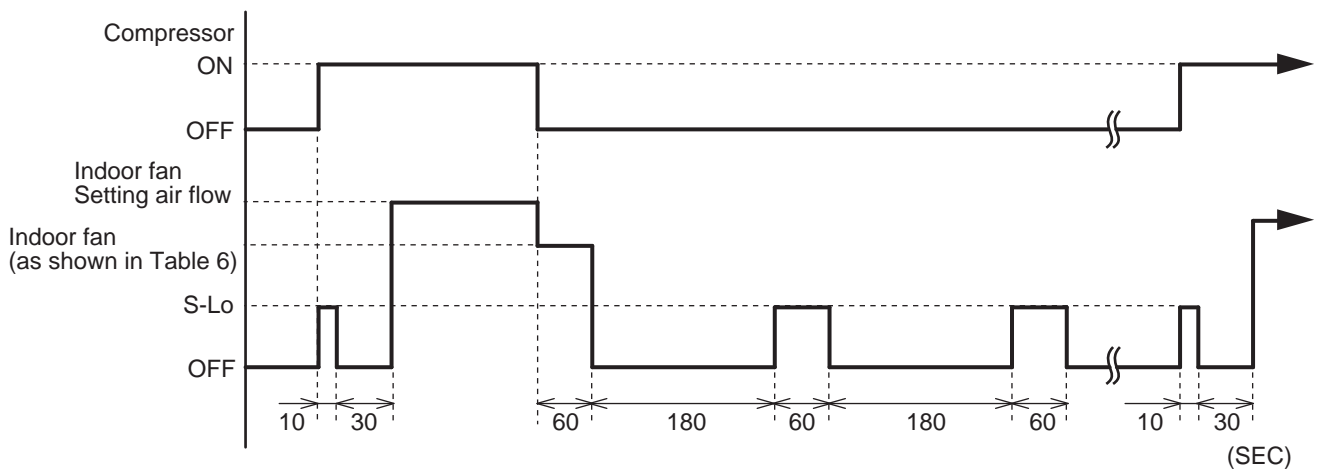

( Table6 : Indoor Fan Speed )

Dry		Cooling
X zone	J zone	
960rpm	720rpm	780rpm

## 6. OUTDOOR FAN CONTROL

### 1. Fan Speed

Zone ※	Cooling	Dry	Heating
D-1	840/ 820/ 740/ 660/ 620/ 450	740/ 620/ 450	1070/ 930/ 760/ 660/ 610/ 580/ 510/ 410
D-2	840/ 820/ 500/ 450/ 410		
F	200/ 180	200/ 180	
G	200/ 170	200/ 170	

(rpm)

※ Refer to Fig. 10

( Fig.10 : Outside air temperature zone selection )

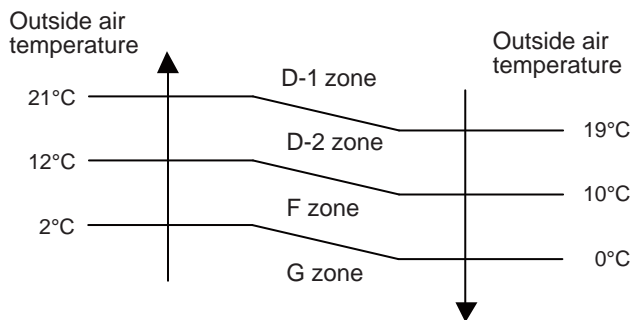

- \* The outdoor fan speed mentioned above depends on the compressor frequency. (When the compressor frequency increases, the outdoor fan speed also changes to the higher speed. When the compressor frequency decreases, the outdoor fan speed also changes to the lower speed.)
- \* After the defrost control is operated on the heating mode, the fan speed keeps at the higher speed as table 7 without relating to the compressor frequency.

( Table 7 : Outdoor fan speed after the defrost )

1070rpm
---------

# 7. LOUVER CONTROL

## 1. VERTICAL LOUVER CONTROL

(Function Range)

Each time the Vertical SET button is pressed, the air direction will change as follow:

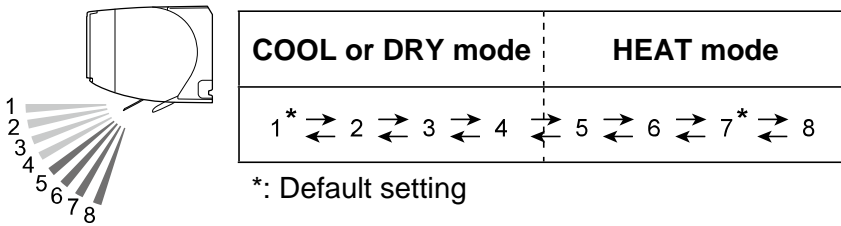

At the beginning of AUTO or HEAT mode, they may stay on position 1 for a while for adjustment.

If the angle is set to position 5 - 8 for more than 30 minutes in COOL or DRY mode, the louver will automatically return to position 4. (\*Keeping the position 5 - 8 during COOL or DRY mode may cause of condensation water drops.)

After beginning of AUTO / HEAT mode operated and automatic defrosting operation time, the air flow will be position 1.

The airflow direction setting will temporarily become 1 when the temperature of the airflow is low at the start of HEAT mode.

At the beginning of AUTO mode, the position you cannot change the airflow direction.

## 2. HORIZONTAL LOUVER CONTROL

(Function Range)

Each time the Vertical SET button is pressed, the air direction will change as follow:

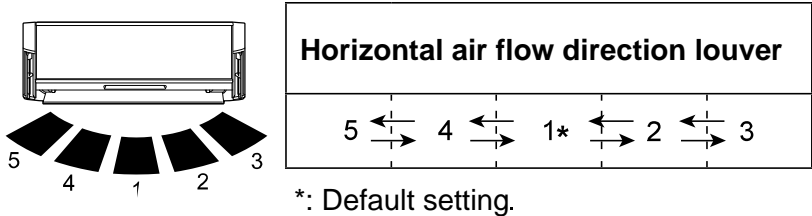

At the beginning of AUTO mode, the position you cannot change the airflow direction.

## 3. SWING OPERATION

(Function Range)

Set the automatic swing operation, Each time the SWING Button is pressed, the operation will change.

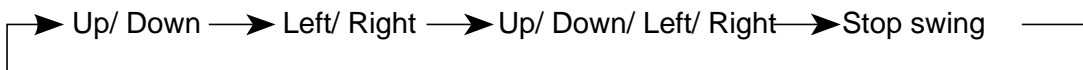

The Left/ Right swing operation will follow the direction as shown above.

The Up/ Down Swing operation range will differ by mode as follows.

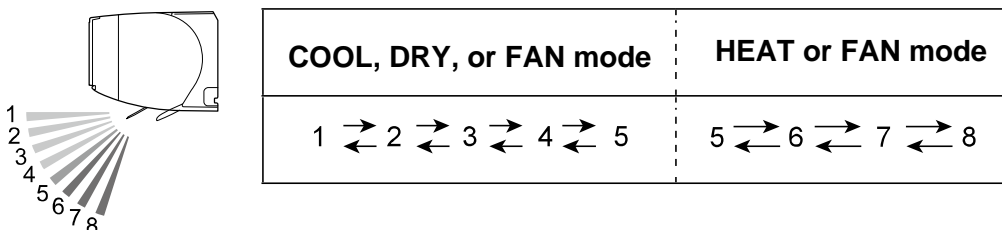

Swing operation may stop temporarily when the indoor unit fan is rotating at very low speed or is stopped. In FAN mode, the UP/ Down swing operation range of 1 ↔ 5 or 5 ↔ 8 is decided according the airflow direction previously set before starting the swing operation

## 8. DUAL FAN CONTROL

### 1. DUAL FAN COMFORT

The 2 types of airflow(cold/warm air from the main fan, and ambient temperature air from the dual fan) provide comfort through the room.

This is recommended for those who do not like ordinary COOL/HEAT modes.

- In COOL mode

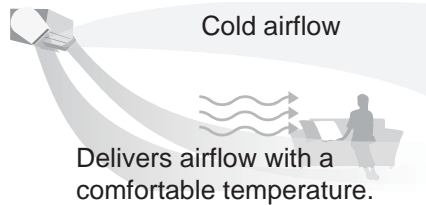

- In HEAT mode

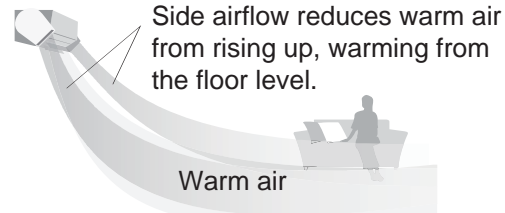

### 2. Operation

Dual FAN is OFF at the time of purchase.

To activate the dual fan comfort, press the "DUAL FAN COMFORT" button.

**DUAL FAN** will be flashing on the remote controller display.

To deactivate the dual fan comfort, press the "DUAL FAN COMFORT" button. again.

**DUAL FAN** will no longer be shown on the remote controller display.

Dual fan operates with the recommended setting. (Refer to the Fig. 11)

Dual fan does not operate in TEST operation by indoor unit button.

Operation only with dual fan is not possible.

In HEAT mode, there is no dual fan airflow with the following.

- When the room temperature is lower than the set temperature
- When the temperature of HEAT airflow is low
- During automatic defrosting operation

In AUTO mode, there is no dual fan airflow with the following.

- When the room temperature is under the monitoring in AUTO mode.

(Fig. 11 )

Louver position	Dual fan position		Remarks
	COOL DRY FAN *	HEAT	
1 (Horizontal)	7	1	Default setting COOL/ DRY/ FAN
2	7	1	
3	7	2	
4	7	2	The lowest down position in dew water protection (COOL/ DRY)
5	7	3	
6	7	4	
7	7	5	Default setting HEAT
8 (Blow down)	7	6	

The dual fan position is controlled together with the louver position Up / Down.

The fan speed is controlled with the fan speed of main fan and the louver position Right / Left.

\*The position 7: (Standard) is able to change to the position 5: (Far) upward. Refer to the setting.

### 3. Setting

The position of dual fan in COOL, DRY or FAN mode can change so that the airflows further.

( For the case that the opposite wall is far from the indoor unit, and the air agitation is required.)

1. Turn off the indoor unit by pressing the "Start/Stop (⏻)" button.
2. Press the "DUAL FAN COMFORT" button for at least 5 seconds until the current "DUAL FAN" status is displayed.
3. Press the "TEMP." buttons (↕) to switch the setting.  
"1" (Standard) ↔ "2" (Far) \*
4. Press the "Start/ Stop (⏻)" button to send the setting to the indoor unit. After the status is sent, the display will automatically return to the original screen.

\*If no buttons are pressed within 30 seconds after the "DUAL FAN" status is displayed, the system returns to the original clock display. In this case, start again from step 1.

If this still does not match the preferences. see the function setting.

# 9. COMPRESSOR CONTROL

## 1. OPERATION FREQUENCY RANGE

The operation frequency of the compressor is different based on the operation mode as shown in Table 8.

(Table 8 : Compressor Operation Frequency Range)

Cooling		Heating		Dry	
Min	Max	Min	Max	Min	Max
15rps	63rps	15rps	128rps	15rps	22rps

## 2. OPERATION FREQUENCY CONTROL AT START UP

The compressor frequency soon after the start-up is controlled as shown in Fig.12.

(Fig.12 : Compressor Control at Start-up)

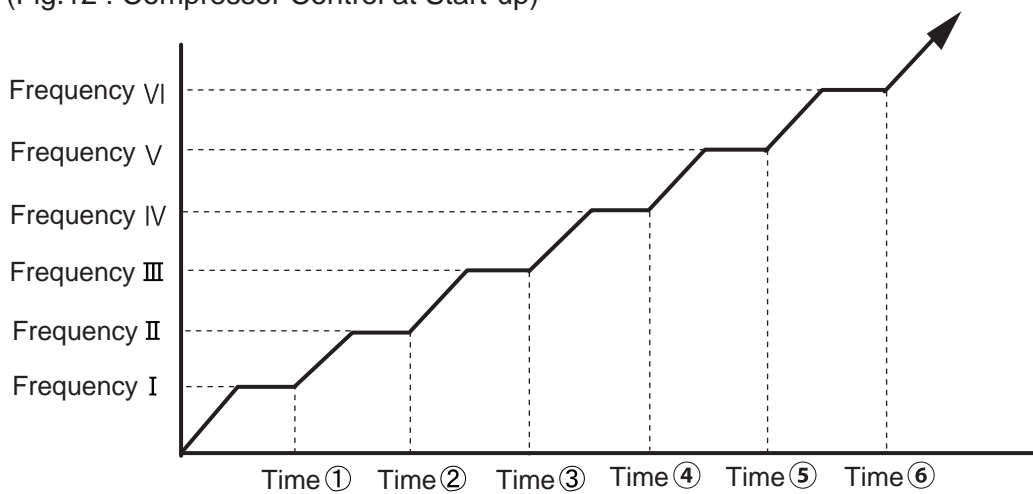

### (Frequency)

Frequency I	Frequency II	Frequency III	Frequency IV	Frequency V	Frequency VI
29rps	53rps	65rps	72rps	91rps	99rps

### (Time)

Time ①	Time ②	Time ③	Time ④	Time ⑤	Time ⑥
80sec	110sec	140sec	200sec	350sec	410sec

# 10. TIMER OPERATION CONTROL

## 10-1 WIRELESS REMOTE CONTROLLER

The Table 9 shows the available timer setting based on the product model.

( Table 9 : Timer setting )

ON TIMER / OFF TIMER	PROGRAM TIMER	SLEEP TIMER
○	○	○

### 1. ON TIMER / OFF TIMER

- OFF timer : When the clock reaches the set time, the air conditioner will be turned off.

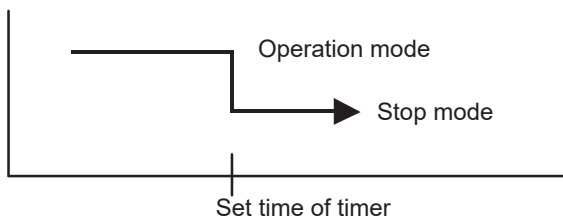

- ON timer : When the clock reaches the set time, the air conditioner will be turned on.

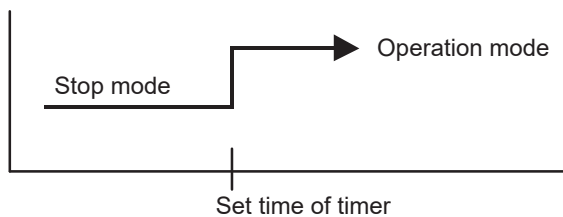

### 2. PROGRAM TIMER

- The program timer allows the OFF timer and ON timer to be used in combination one time.

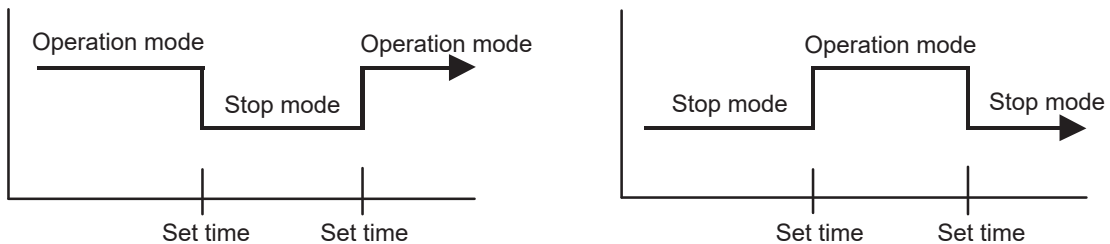

- Operation will start from the timer setting (either OFF timer or ON timer) whichever is closest to the clock's current timer setting.  
The order of operations is indicated by the arrow in the remote control unit's display.
- SLEEP timer operation cannot be combined with ON timer operation.

### 3. SLEEP TIMER

If the sleep is set, the room temperature is monitored and the operation is stopped automatically. If the operation mode or the set temperature is change after the sleep timer is set, the operation is continued according to the changed setting of the sleep timer from that time ON.

#### In the cooling operation mode

When the sleep timer is set, the setting temperature is increased 1°C

It increases the setting temperature another 1°C after 1 hour.

After that, the setting temperature is not changed and the operation is stopped at the time of timer setting.

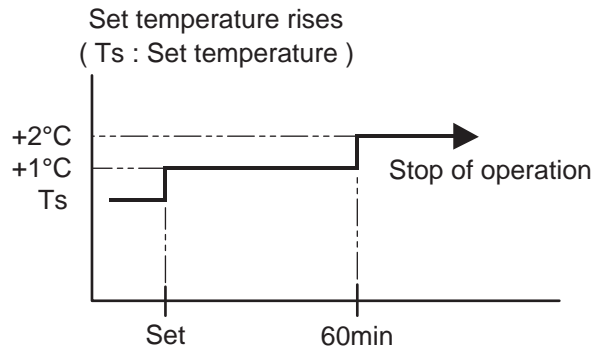

#### In the heating operation mode

When the sleep timer is set, the setting temperature is decreased 1°C

It decreases the setting temperature another 1°C every 30 minutes.

Upon lowering 4°C, the setting temperature is not changed and the operation stops at the time of timer setting.

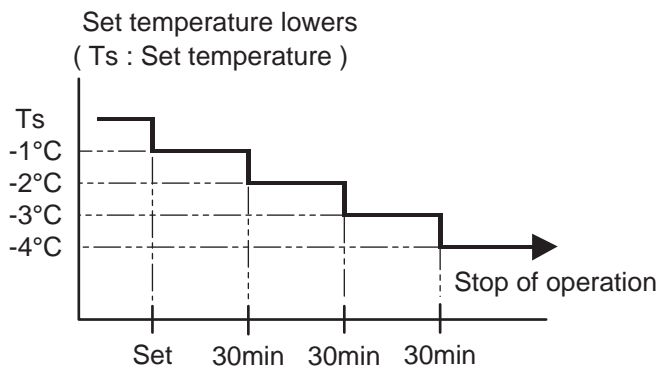



## 11. ELECTRONIC EXPANSION VALVE CONTROL

The most proper opening of the electronic expansion valve is calculated and controlled under the present operating condition based on the Table10.

The compressor frequency, the temperatures detected by the discharge temperature sensor, the indoor heat exchanger sensor, the outdoor heat exchanger sensor, and the outdoor temperature sensor.

( Table10 : The pulse range of the electronic expansion valve control )

Operation mode	Pulse range
Cooling / Dry mode	between 32 to 480 pulses.
Heating mode	between 32 to 480 pulses.

\* At the time of supplying the power to the outdoor unit, the initialization of the electronic expansion valve is operated (528 pulses are input to the closing direction).

## 12. TEST OPERATION CONTROL

Operation method

Before starting the test run, wait for 1 minute after connecting the power supply.

By the wireless remote controller

- To start the test run, press the "Start/Stop (⏻/⏹)" button, the "TEST RUN" button on the remote controller with a by using the tip of a ballpoint pen or other small object.

By the indoor unit button

- To start the test run, keep on pressing the "INDOOR UNIT" button of the indoor unit for more than 10 sec.
- To end test operation, press the remote controller "Start/Stop (⏻/⏹)" button.

(When the air conditioner is running by pressing the "TEST RUN" button, the "OPERATION" indicator and "TIMER" indicator blink simultaneously.)

## 13. PREVENT TO RESTART ( ST )

The compressor won't enter operation status for 140 sec. after the compressor is stopped, even if any operation is given.

## 14. FOUR-WAY VALVE EXTENSION SELECT

At the time when the air conditioner is switched from the cooling mode to heating mode, the compressor is stopped, and the four-way valve is switched in 140 sec. later after the compressor Stopped.

At the time when the compressor stopped during heating mode, the four-way valve position changes to the cooling position with certain period as follows.

- When the compressor is stopped by the operation STOP: after 140 sec.
- When the compressor is stopped by other than above: after 1800 sec.

## 15. AUTO RESTART

When the power was interrupted by a power failure, etc. during operation, the operation contents at that time are memorized and when power is recovered, operation is automatically started with the memorized operation contents.

When the power is interrupted and recovered during timer operation, since the timer operation time is shifted by the time the power was interrupted, an alarm is given by blinking slowly (6 sec ON/2 sec OFF) the indoor unit body timer indicator.

[ Operation contents memorized when the power is interrupted ]

- Operation mode
- Set temperature
- Set air flow
- Timer mode and timer time
- Set air flow Direction
- Swing
- ECONOMY operation
- 10°C HEAT operation
- Human sensor setting
- Low noise operation

## 16. FORCED AUTO OPERATION

If the Indoor unit button is pressed 3 to 10 sec. the operation is controlled as shown in Table 11. (If the remote controller is lost, this function can use.)

The Operation indicator and the Timer indicator blinks for 1 sec. ON, and 1 sec. OFF.

The forced auto operation is released after 60 min. after starting the operation.

By pressing the Indoor unit button for 3sec., the operation stops.

(Table11)

	Manual auto operation
OPERATION MODE	Auto changeover
FAN CONT. MODE	Auto
TIMER MODE	Continuous (No timer setting available)
SETTING TEMP.	24°C
SETTING LOUVER	Standard / Momorized position
DUAL FAN	OFF
HUMAN SENSOR	OFF
ECONOMY	OFF
SWING	OFF

## 17. FORCED COOLING OPERATION

If the Indoor unit button is pressed over 10 sec., the operation is controlled as shown in Table 12. (If the remote controller is lost, this function can use.)

The Operation indicator and the Timer indicator blinks for 1 sec. ON, and 1 sec. OFF.

The forced auto operation is released after 60 min. after starting the operation.

By pressing Indoor unit button for 3 sec., the operation stops.

(Table12)

	Manual auto operation
OPERATION MODE	COOL
FAN CONT. MODE	Hi
TIMER MODE	Continuous (No timer setting available)
SETTING TEMP.	24°C
SETTING LOUVER	Standard
DUAL FAN	OFF
HUMAN SENSOR	OFF
ECONOMY	OFF
SWING	OFF

## 18. COMPRESSOR PREHEATING

When the time elapsed 30 min, after compressor stopped, and when the outdoor heat exchanger temperature sensor detects lower temperature, the preheating starts.

When the operation starts, the preheating stops.

The preheating does not operate when the system is stopped with Error of permanent stop.

( Fig.13:Compressor Preheating )

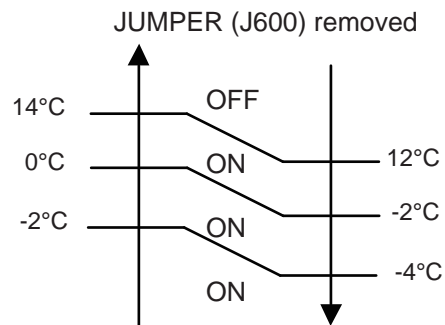
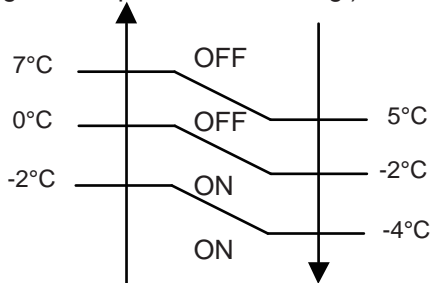

## 19. 10°C HEAT OPERATION

The 10°C HEAT operation functions by pressing 10°C HEAT button on the remote controller. When the 10°C HEAT operation is operating, the ECONOMY indicator turns ON.

The 10°C HEAT operation is almost the same operation as below settings.

( Table13 )

Mode	Heating
Setting temperature	10°C
Fan mode	Lo (AUTO)

## 20. ECONOMY OPERATION

The ECONOMY operation functions by pressing ECONOMY button on the remote controller. The ECONOMY operation is almost the same operation as below settings.

( Table14 )

Mode	Cooling/ Dry	Heating
Target temperature	Setting temp.+1°C	Setting temp.-1°C

## 21. DEFROST OPERATION CONTROL

### 1. CONDITION OF STARTING THE DEFROST OPERATION

The defrost operation starts when the outdoor heat exchanger temperature sensor (Tn) detects the temperature lower than the values shown in Table15.

( Table 15 : Condition of starting Defrost Operation )

Defrosting (Normal) starting operation	Compressor integrating operation time	
	Less than 40min.	More than 40min.
	Does not operate	$T_n \leq -17^{\circ}\text{C}$ $T_n - \bar{T}_{n10} < -5\text{deg}$ $T_n - T_{nb} < -2\text{deg}$ However, $T_n \leq -6^{\circ}\text{C}$

Tn10 : Temperature of continuous operation at 10minutes.

Tnb : Back 5minutes temperature

Integrating defrost (Constant monitoring)	Compressor integrating operation time		
	More than 240min. (For long continuous operation)	More than 215min. (For long continuous operation)	Less than 10min.*1 (For intermittent operation)
	-3°C	-5°C	OFF count of the compressor 40 times.

\*1 : If the compressor continuous operation time is less than 10 min, the OFF number of the compressor is counted.  
If any defrost operated, the compressor OFF count is cleared.

### 2. CONDITION OF THE DEFROST OPERATION COMPLETION

Defrost operation is released when the conditions become as shown in Table16.

( Table16 : Defrost Release Condition )

Release Condition
Outdoor heat exchanger temperature sensor value is higher than +16°C or Compressor operation time has passed 15min.

### 3. Defrost Flow Chart

The defrosting shall proceed by the integrating operation time, outdoor temperature and outdoor heat exchanger temperature as follows.

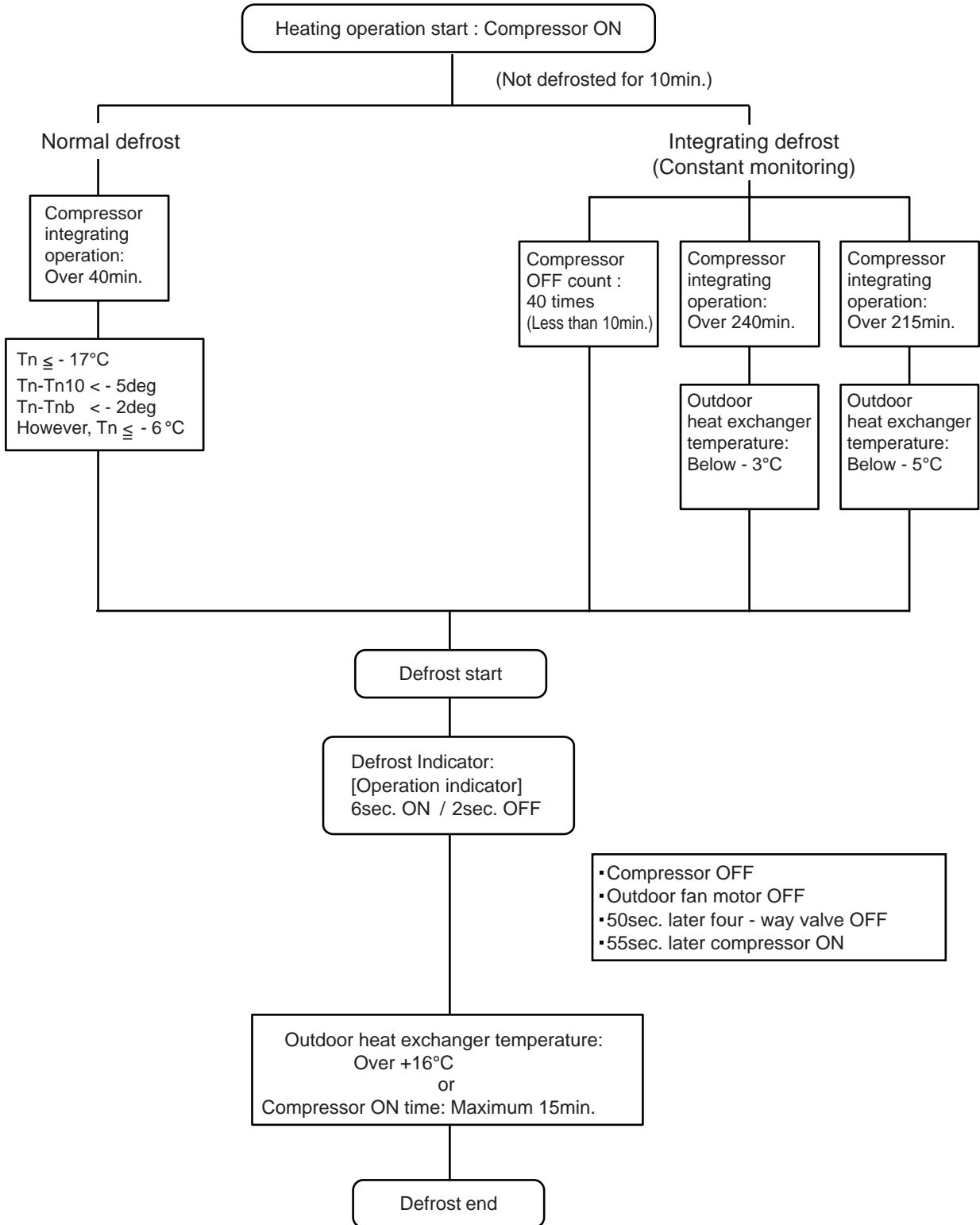

## 22. OFF DEFROST OPERATION CONTROL

When operation stops in the [Heating] mode, if frost is adhered to the outdoor unit heat exchanger, the defrost operation will proceed automatically. In this time, if indoor unit operation indicator flashes slowly (6 sec ON / 2 sec OFF), the outdoor unit will allow the heat exchanger to defrost, and then stop.

### 1. OFF DEFROST OPERATION CONDITION

In heating operation, the outdoor heat exchanger temperature is less than  $-4^{\circ}\text{C}$ , compressor continuous operation more than 10 minutes, and compressor operation integrating time lasts for more than 30 minutes.

### 2. OFF DEFROST END CONDITION

Release Condition
Outdoor heat exchanger temperature sensor value is higher than $+16^{\circ}\text{C}$ or Compressor operation time has passed 15 minutes.

### OFF Defrost Flow Chart

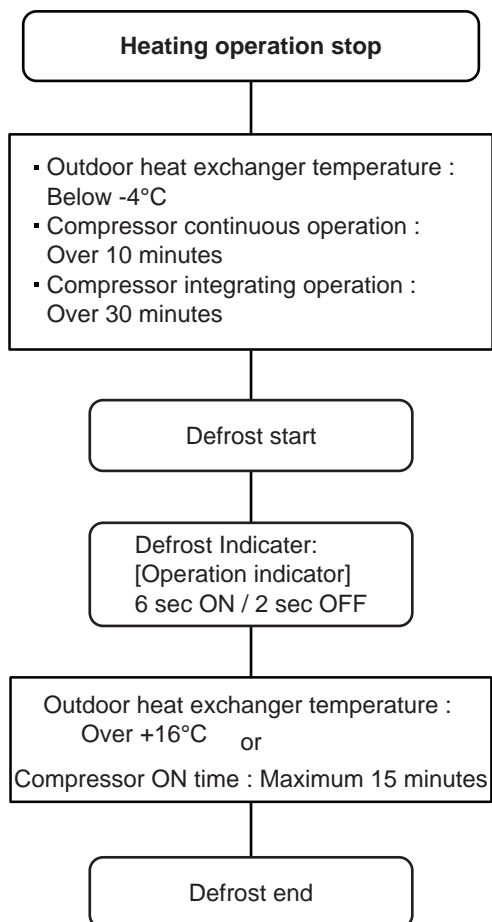

## 23. VARIOUS PROTECTIONS

### 1. DISCHARGE GAS TEMPERATURE OVERRISE PREVENION CONTROL

The discharge gas thermosensor (discharge thermistor : Outdoor side) will detect discharge gas temperature.

When the discharge temperature becomes higher than Temperature I, the compressor frequency is decreased 20rps, and it continues to decrease the frequency for 20rps every 120 seconds until the temperature becomes lower than Temperature I.

When the discharge temperature becomes lower than Temperature II, the control of the control of the compressor frequency is released.

When the discharge temperature becomes higher than Temperature III, the compressor is stopped and the indoor unit indicator starts blinking.

( Table 17 : Discharge Temperature Over Rise Prevension Control / Release Temperature )

Temperature I	Temperature II	Temperature III
104°C	101°C	110°C

### 2. CURRENT RELEASE CONTROL

The compressor frequency is controlled so that the outdoor unit input current does not exceeds the current limit value that was set up with the outdoor temperature.

The compressor frequency returns to the designated frequency of the indoor unit at the time when the frequency becomes lower than the release value.

( Table 18 : Current Release Operation Value / Release Value)

#### Model 09

##### [ Heating ]

TO (Control / Release)	
17°C	8.5A / 8.0A 10.5A / 10.0A
12°C	12.5A / 12.0A

##### [ Cooling ]

TO (Control / Release)	
46°C	4.5A / 4.0A 6.0A / 5.5A
40°C	7.0A / 6.5A

#### Model 12

##### [ Heating ]

TO (Control / Release)	
17°C	10.5A / 10.0A 12.5A / 12.0A
12°C	14.5A / 14.0A

##### [ Cooling ]

TO (Control / Release)	
46°C	5.0A / 4.5A 6.5A / 6.0A
40°C	7.5A / 7.0A

TO : Outdoor Temperature

### 3. ANTIFREEZING CONTROL (Cooling and Dry mode)

The compressor frequency is decrease on cooling & dry mode when the indoor heat exchanger temperature sensor detects the temperature lower than Temperature I.

Then, the anti-freezing control is released when it becomes higher than Temperature II.

( Table 19 : Anti-freezing Protection Operation / Release Temperature )

Outdoor temperature	Temperature I	Temperature II
Over than 10°C *1 or 12°C *2	4°C	7°C
Less than 10°C *1 or 12°C *2		13°C

\*1. When the temperature rises.

\*2. When the temperature drops.

#### 4. COOLING PRESSURE OVERRISE PROTECTION

When the outdoor unit heat exchange sensor temperature rises to 65°C or greater the compressor is stopped. The compressor restarts after the 140 sec. elapsed (ST). and the temperature detection starts 60 sec. elapsed after compressor started.

#### 5. HIGH TEMPERATURE AND HIGH PRESSURE RELEASE CONTROL ( HEATING MODE )

On heating mode, the compressor frequency is controlled as following based on the detection value of the indoor heat exchanger temperature sensor.

[ Control System ]

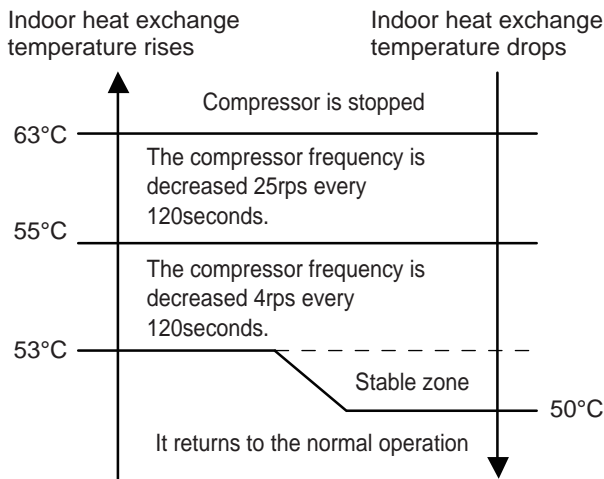

#### 6. HIGH PRESSURE PROTECTION

When the pressure switch becomes OFF (Open : higher than 4.2 MPa), the compressor is stopped.

It is released when the pressure switch becomes ON (Close : lower than 3.2 MPa) after 140sec. of compressor stop.

#### 7. 4 way valve protection

The 4 way valve protection operates with the following conditions.

1. When the compressor operates for more than 20 minutes.
2.  $T_n$  (Indoor unit HEX temp) -  $T_b$  (Room temp) > 10 deg in COOL and DRY
3.  $T_n$  (Indoor unit HEX temp) -  $T_b$  (Room temp) < -10 deg in HEAT

When the above condition 1&2 or 1&3 repeat 2 times for 2 min, the compressor stops.

When the same condition repeats 5 times, the system indicates the Error code.

#### 8. Dew water protection (Operating in COOL, DRY)

When the vertical louver is set the position 5 ~ 8, and when the operating time elapsed 30 minutes, the louver position changes automatically to the position 4.

#### 9. EEV shutoff protection (Operating in HEAT)

The EEV shutoff protection operates with the following conditions.

1. When the compressor operates for more than 20 minutes.
2.  $T_n$  (Indoor unit HEX temp) -  $T_b$  (Room temp) < 4 deg

When the above condition 1 and 2 repeat 2 times in 2 min, the compressor stops.

After the ST (Restart protection), the compressor starts.



## 24. LOW NOISE OPERATION

The compressor speed and the outdoor unit fan speed are limited to reduce the operation noise by pressing "LOW NOISE" button on the remote controller.

However, during the DEFROST OPERATION, the compressor operates by the speed for DEFROST OPERATION.

Operating mode	Outdoor fan speed [rpm]	Compressor speed [rps]
COOL, DRY	660	32
HEAT	660	32

\*The performance drops when operating in the LOW NOISE OPERATION.

## 25. HUMAN SENSOR (Energy Saving)

### • About the ENERGY SAVING Operation

If no one enters the room for approximately 20 minutes, the set temperature will be automatically controlled.

(When someone comes back into the room, the human sensor will detect this, and automatically revert to the original settings.)

Operation mode	Operation details (if there is no one in the room for a while)
Cool / Dry	The set temperature will be increased by a maximum of approximately 2°C.
Heat	The set temperature will be decreased by a maximum of approximately 4°C.
Auto	This runs the ENERGY SAVING function automatically for the selected mode (Cooling/ Heating/ Drying)

\* High limit : 30°C

\* Low limit : 16°C

\* When using together with the SLEEP time, the SLEEP timer will be prioritized.

\* During 10°C HEAT operation, if there is no one in the room the set temperature will not be changed.

Application range is follows.

Vertical angle 90°(Side view)

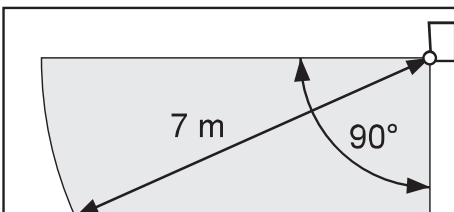

Horizontal angle 100°(Top view)

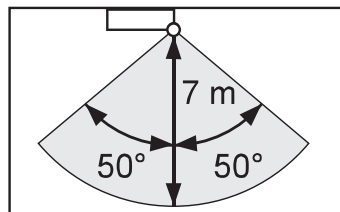

ENERGY SAVING function may not work when the room temperature is very different from the temperature defined in temperature setting, such as when immediately after starting the operation

### About the HUMAN SENSOR

- Details about detection with the human sensor
  - The human sensor detects whether there are people in the room by looking for movement by people in the room.

## 26. POWERFUL OPERATION

The Powerful operation functions by pressing POWERFUL button on the remote controller. The indoor unit & outdoor unit will operate at maximum power as shown in Table 20.

(Table 20)

	Powerful operation
COMPRESSOR FREQUENCY	Maximum
FAN CONT. MODE	Powerful
SETTING LOUVER	Cooling/ Dry : 4, Heating : 7

Release Condition is as follows.

[Cooling / Dry]

- Room temperature  $\leq$  Setting temperature - 0.5°C or Operation time has passed 20 min..

[Heating]

- Room temperature  $\geq$  Setting temperature +0.5°C or Operation time has passed 20 min..

## 27. FILTER CLEAN

The Filter clean function operates with the following conditions.

### 1. Auto filter clean

When the air conditioner operating time reached 40 hours\*.

\*Filter clean operation interval time can change by the function setting.

### 2. Manual filter clean

When the Filter Clean button on the remote controller is pressed.

The filter cleaning time is approximately 13 min..

The indoor unit "FILTER CLEAN" indicator lights up during filter cleaning.

When the FILTER CLEAN indicator blinks slowly, this indicates that it is time to clean the dust box. (After approximately 10,000 hours of air conditioner operation have elapsed.)

After cleaning the dust box, press Indoor unit button less than 3 sec..

By pressing the indoor unit button, the accumulated operation time is reset.

When the indicator blinks as follows, check filter installing (refer to the operation manual.)



"OPERATION" : 5 times

"TIMER" : 5 times

"ECONOMY" : Blinking fast

## 28. PLASMA CLEAN

The plasma clean function operates with the following conditions.

- When the plasma air clean button on the remote controller is pressed.
- When the Indoor unit main fan is rotating at very low speed or is stopped.

The indoor unit "PLASMA AIR CLEAN" indicator lights up during the functioning.

When the PLASMA AIR CLEAN indicator blinks slowly, this indicates that it is time to clean the plasma air clean unit. (After approximately 1,100 hours of plasma air clean operation have elapsed.) After cleaning the plazma clean unit (refer to the operation manual), press Indoor unit button less than 3 sec..

By pressing the indoor unit button, the accumulated operation time is reset.

When the PLASMA AIR CLEAN indicator blinks, this indicates that the plasma clean unit is wet, dirty or the intake grille is opened.

In this case, stop the air conditioner and then check intake grille or clean the plasma clean unit and dry it completely.

## 29. WIRELESS LAN

The operation with the wireless LAN is possible by using the wireless LAN adaptor (packaged with the manuals), and by performing the network setting.

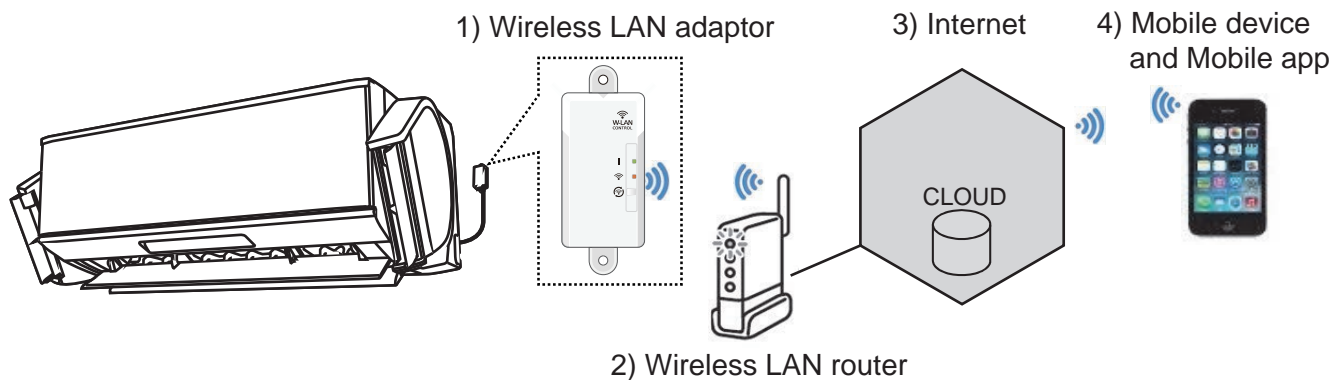

### 1) Wireless LAN adaptor

The adaptor is packaged with the manuals.

The SSID is in the label with the wireless LAN adaptor.

For the installing and setting, refer to the installation manual and the setting manual.

The wireless adaptor has the LED indicator, and it indicates the status.

In case of trouble, refer to the troubleshooting or setting manual.

### 2) Wireless LAN router

Local purchase (use the user's product)

PIN code or WPS (setting) is required for linking with the wireless LAN adaptor.

The internet connection is required.

### 3) Internet

The operation and the status indication are performed via the Internet.

### 4) Mobile device and Mobile app

Mobile app (application software) "FGLair" has to be installed to the user's mobile device.

(For installing the app, the user registration is required. Refer to the setting manual.)

The function available on the mobile device may differ from the function on the remote controller.

(Refer to the operation manual of mobile app)

# ***WALL MOUNTED type INVERTER***

## **2 . TROUBLESHOOTING**

## 2-1 INDOOR UNIT ERROR DISPLAY

### INDOOR UNIT LED INDICATOR

Please refer the flashing pattern as follows.

The OPERATION, TIMER and ECONOMY indicators operate as follows according to the error contents.

OPERATION, TIMER indicator : 0.5s ON / 0.5s OFF (Flash)

ECONOMY indicator: 0.1s ON / 0.1s OFF (Flash continuous)

Error Contents	Indoor Unit Display			Trouble shooting
	OPERATION (Green)	TIMER (Orange)	ECONOMY (Green)	
Serial Communication Error	1 time	1 time	Continuous	1, 2
External Communication Error	1 time	8 times	Continuous	26,29,30
Combination Error	2 time	3 times	Continuous	3
Power Supply Frequency Detection Error	3 times	1 time	Continuous	4
Indoor unit Model Information Error	3 times	2 times	Continuous	5
Manual Auto Switch Error	3 times	5 times	Continuous	6
Room Temperature Thermistor Error	4 times	1 time	Continuous	7
Indoor unit Heat Ex. Thermistor Error	4 times	2 times	Continuous	8
Indoor Fan Motor Error	5 times	1 time	Continuous	9
Plasma air clean unit Vdd Error	5 times	4 times	Continuous	10
Filter set abnormal	5 times	5 times	Continuous	11
Side Fan ( Left ) Motor Error	5 times	9 times	Continuous	12
Side Fan ( Right ) Motor Error	5 times	10 times	Continuous	13
Outdoor unit Model Information Error	6 times	2 times	Continuous	14
Trip terminal L Error	6 times	5 times	Continuous	15
Outdoor unit Discharge Thermistor Error	7 times	1 time	Continuous	16
Outdoor unit Heat Ex. Thermistor Error	7 times	3 times	Continuous	17
Outdoor Temperature Thermistor Error	7 times	4 times	Continuous	18
CT Error	8 times	4 times	Continuous	19
High pressure SW Error	8 times	6 times	Continuous	20
Over current Error	9 times	4 times	Continuous	21
Compressor start up Error	9 times	5 times	Continuous	22
Outdoor Unit Fan Motor Error	9 times	7 times	Continuous	23
4 Way Valve Error	9 times	9 times	Continuous	24
Discharge Temperature Error	10 times	1 time	Continuous	25

## 2-2 WIRELESS LAN ADAPTER ERROR DISPLAY

### WIRELESS LAN ADAPTER INDICATOR

Please refer the flashing pattern as follows.

LED 1 (green) and LED 2 (orange) operate as follow according to the error contents.

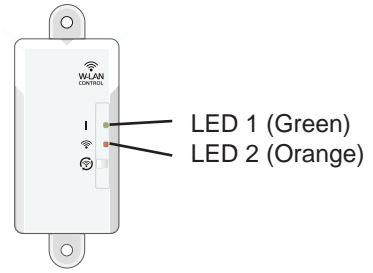

\*The status LED1(Green) ON: The communication between the Indoor unit and the adaptor is normal.

Error Contents	Wireless LAN adapter Indicator		Error code	Trouble shooting
	LED 1 (Green)	LED2 (Orange)		
External Communication Error (Communication Error of between Indoor unit to wireless LAN adapter)	Flashing Fast	ON	18	26
Wireless LAN addapter Error	Flashing Fast	Flashing Fast	No Error	27
Network Communication Error (Communication Error of between Wireless LAN router to Wireless LAN adapter)	ON	Flashing Fast	No Error	28
Communication Error ("Troubleshooting 26" and "Troubleshooting 28" are simultaneous Error)	Flashing Fast	Flashing Fast	18	29
Wireless LAN adapter Non-Energized	OFF	OFF	18	30
Wireless LAN adapter Sleep mode	OFF	OFF	No Error	31

Flashing Fast : Repeating 0.5 seconds ON / 0.5 seconds OFF

## 2-3 MOBILE APP ERROR DISPLAY

### MOBILE APP ERROR DISPLAY

If there is an abnormality on the air conditioning, you will see ⚠ is as follows.

When you tap the "Error button" ⚠ on the home screen, Error Code and Error Name is displayed.

#### For Android



#### For iOS



## 2. ERROR CODE

Error Contents	Applicable Error code	Trouble shooting
Serial Communication error between Indoor unit/outdoor unit	11.1, 11.2, 11.3, 11.4	1, 2
External Communication error	18.1	26,29,30
Incompatible series connection error	23.1	3
Indoor unit power supply abnormal	31.3	4
Indoor unit main PCB error	32.1	5
Indoor unit manual auto switch error	35.1	6
Indoor unit room temp. thermistor error	41.1	7
Indoor unit heat ex. temp. thermistor error	42.1	8
Indoor unit fan motor 1 error	51.1, 51.2	9
Air cleaning function error	54.1, 54.2	10
Indoor unit intake grille position error	58.1	11
Indoor unit fan motor 2 error	59.1	12
Indoor unit fan motor 3 error	5A.1	13
Outdoor unit main PCB error	62.1, 62.2	14
Outdoor unit IPM error	65.3	15
Outdoor unit discharge temp. thermistor error	71.1	16
Outdoor unit heat ex. temp. thermistor error	73.3	17
Outside air temp. thermistor error	74.1	18
Outdoor unit current sensor error	84.1	19
Outdoor unit pressure sensor Error	86.4	20
Outdoor unit trip detection	94.1	21
Outdoor unit compressor motor control error	95.1	22
Outdoor unit Fan Motor 1 error	97.3	23
Outdoor unit 4 way valve error	99.1	24
Outdoor unit discharge temp. 1 error	A1.1	25

## 2-4 MOBILE APP ERROR DISPLAY (In Wireless LAN Control system)

### 1. ERROR DISPLAY

If there is an abnormality on the Wireless LAN control system, you will see is as follows. Error messages will disappear at 5 seconds. Then return to normal display.

#### For Android

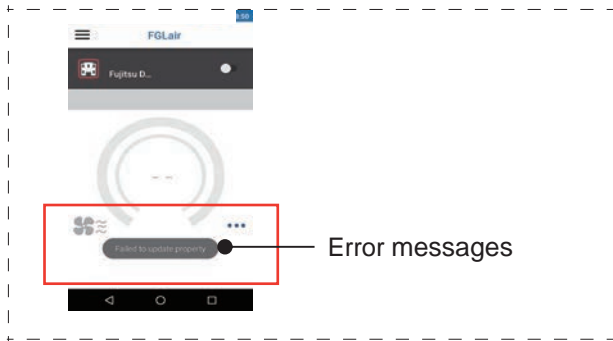

#### For iOS

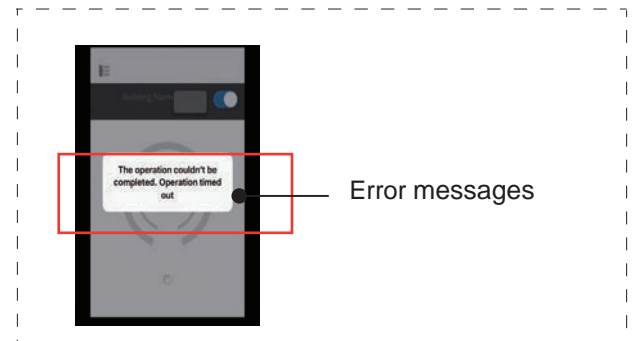

### 2. ERROR MESSAGES LIST

#### ■ Mobile app errors

#### Registration Errors (For Android)

Error messages	Causes	Solutions
Wi-Fi must be enabled to set up new device	The user has disabled Wi-Fi on their mobile device.	Enable Wi-Fi from the Android setting.
We weren't able to sign you onto null. Please go to the Wi-Fi settings and join the network from there. Return to the app when you're done.	The mobile device and air conditioner are connected to different Wi-Fi networks when attempting to register.	Connect the mobile device to the same network as the air conditioner, then retry the registration.
Could not connect to the device at this time. Please reset the device and try again.	The air conditioner is not connected to Wi-Fi.	Check if the router connected to the air conditioner has internet access. (You can check by connecting the mobile device to the router, then opening the website.) If there is no access, connect the router to the internet.
	Mobile device is not connected to the same network as the air conditioner.	Connect the mobile device to the same network as the air conditioner, then retry the registration.
The device failed to connect with service.	Your internet access may be down or a firewall may be blocking requests to the service.	Check if the router connected to the air conditioner has internet access. (You can check by connecting the mobile device to the router, then opening the website.) If there is no access, connect the router to the internet, then retry the registration.



Error messages	Causes	Solutions
<p>Could not register the device. Make sure the device is ready for registration.</p>	<p>The air conditioner is not connected to the router.</p>	<p>Enter the Wi-Fi setting on the mobile device, then check if the SSID of the air conditioner (AC-UTY-***** ***) is connected. If the air conditioner is connected, retry the registration.</p>
	<p>The router the air conditioner is connected to, has no internet access.</p>	<p>Check if the router connected to the air conditioner has internet access. (You can check by connecting the mobile device to the router, then open the website.) If there is no access, connect the router to the internet, then retry the registration.</p>
	<p>The air conditioner is already registered.</p>	<p>If there is a mobile device that has already been registered to the air conditioner, unregister by using the registered mobile device. Retry the registration with the mobile device you wish to register.</p> <p>If you do not own the mobile device registered to the air conditioner (lost, property of previous owner, etc.), please ask your maker service to unregister the mobile device. Please notify the MAC address of the WLAN adapter as written on the Wireless LAN label.</p>
	<p>*If the problem persists even if the all of the above is conducted, please contact your dealer or authorized service personnel. When asking for advice, please notify the MAC address of the WLAN adapter as written on the Wireless LAN label.</p>	

## Registration Errors (For iOS)

Error messages	Causes	Solutions
You need an internet connection to add new devices.	The user has disabled Wi-Fi on their mobile device.	Enable Wi-Fi from the iOS setting.
Could not register same LAN device. Make sure both devices are in the same LAN and try again to register.	The mobile device and air conditioner are connected to different Wi-Fi networks when attempting to register.	Connect the mobile device to the same network as the air conditioner, then retry the registration.
No registrable device was found. Make sure Wi-Fi setup was successful. This method only works if the Wi-Fi was recently performed.	The air conditioner is not connected to Wi-Fi.	Check if the router connected to the air conditioner has internet access. (You can check by connecting the mobile device to the router, then opening the website.) If there is no access, connect the router to the internet.
	Mobile device is not connected to the same network as the air conditioner.	Connect the mobile device to the same network as the air conditioner, then tap register button.
Could not register the device. Make sure the device is ready for registration.	The air conditioner is not connected to the router.	Enter the Wi-Fi setting on the mobile device, then check if the SSID of the air conditioner (AC-UTY-***** ***) is connected. If the air conditioner is connected, retry the registration.

Error messages	Causes	Solutions
<p>Could not register the device. Make sure the device is ready for registration.</p>	<p>The router the air conditioner is connected to, has no internet access.</p>	<p>Check if the router connected to the air conditioner has internet access. (You can check by connecting the mobile device to the router, then opening the website.) If there is no access, connect the router to the internet, then retry the registration.</p>
	<p>The air conditioner is already registered.</p>	<p>If there is a mobile device that has already been registered to the air conditioner, unregister by using the registered mobile device. Retry the registration with the mobile device you wish to register.</p> <p>If you do not own the mobile device registered to the air conditioner (lost, property of previous owner, etc.), please ask your maker service to unregister the mobile device. Please notify the MAC address of the WLAN adapter as written on the Wireless LAN label.</p>
	<p>*If the problem persists even if the all of the above is conducted, please contact your dealer or authorized service personnel. When asking for advice, please notify the MAC address of the WLAN adapter as written on the Wireless LAN label.</p>	

## General Errors (For Android)

Error messages	Causes	Solutions
No connectivity to Wi-Fi or the cloud. Please check your network connection.	The mobile device has no internet access.	Connect the mobile device to the internet.
An error occurred while trying to update your profile. Please try again later.		
Device is offline and cannot be modified.	The router the air conditioner is connected to, has no internet access.	Check if the router connected to the air conditioner has internet access. (You can check by connecting the mobile device to the router, then opening the website.) If there is no access, connect the router to the internet.
	The air conditioner is not connected to the router.	Check the LED indicators on the WLAN adapter. If the Green or Orange LED lamp is flashing or off, please check the TROUBLESHOOTING "State of the Wireless LAN indicators".

## General Errors (For iOS)

Error messages	Causes	Solutions
Failed to change password.	The mobile device has no internet access.	Connect the mobile device to the internet.
Cloud not determine service reachability.		
Failed to update property.		
Could not retrieve schedules.		
The operation couldn't be completed. Operation timed out.		
"Device name" is offline. (Device name varies depending on the air conditioner)	The router the air conditioner is connected to has no internet access.	Check if the router connected to the air conditioner has internet access. (You can check by connecting the mobile device to the router, then opening the website to check access.) If there is no access, connect the router to the internet.
	The air conditioner is not connected to the router.	Check the LED indicators on the WLAN adapter. If the Green or Orange LED lamp is flashing or off, please check the TROUBLESHOOTING "State of the Wireless LAN indicators".

## Sign-in Errors (For Android/iOS)

Error messages	Causes	Solutions
Could not reach service.	The mobile device has no internet access.	Connect the mobile device to the internet.

## 2-5 TROUBLE SHOOTING WITH ERROR CODE

<p><b>Trouble shooting 1</b>  <b>OUTDOOR UNIT Error Method:</b>  <b>Serial Communication Error</b>  <b>(Serial Reverse Transfer Error)</b></p>	<p><b>Indicate or Display:</b>  Indoor Unit :  Operation indicator: 1 time Flash  Timer indicator: 1 time Flash  Economy indicator: Continuous Flash  Error code: [ E: 11 ]</p>
<p><b>Detective Actuators:</b>  Outdoor unit Main PCB  Outdoor unit Fan motor</p>	<p><b>Detective details:</b>  When the indoor unit cannot receive the serial signal from Outdoor unit more than 2minutes after power ON, or the indoor unit cannot receive the serial signal more than 15seconds during normal operation.</p>

**Forecast of Cause:**

1. Connection failure   2. External cause   3. Main PCB failure   4. Outdoor unit Fan motor failure

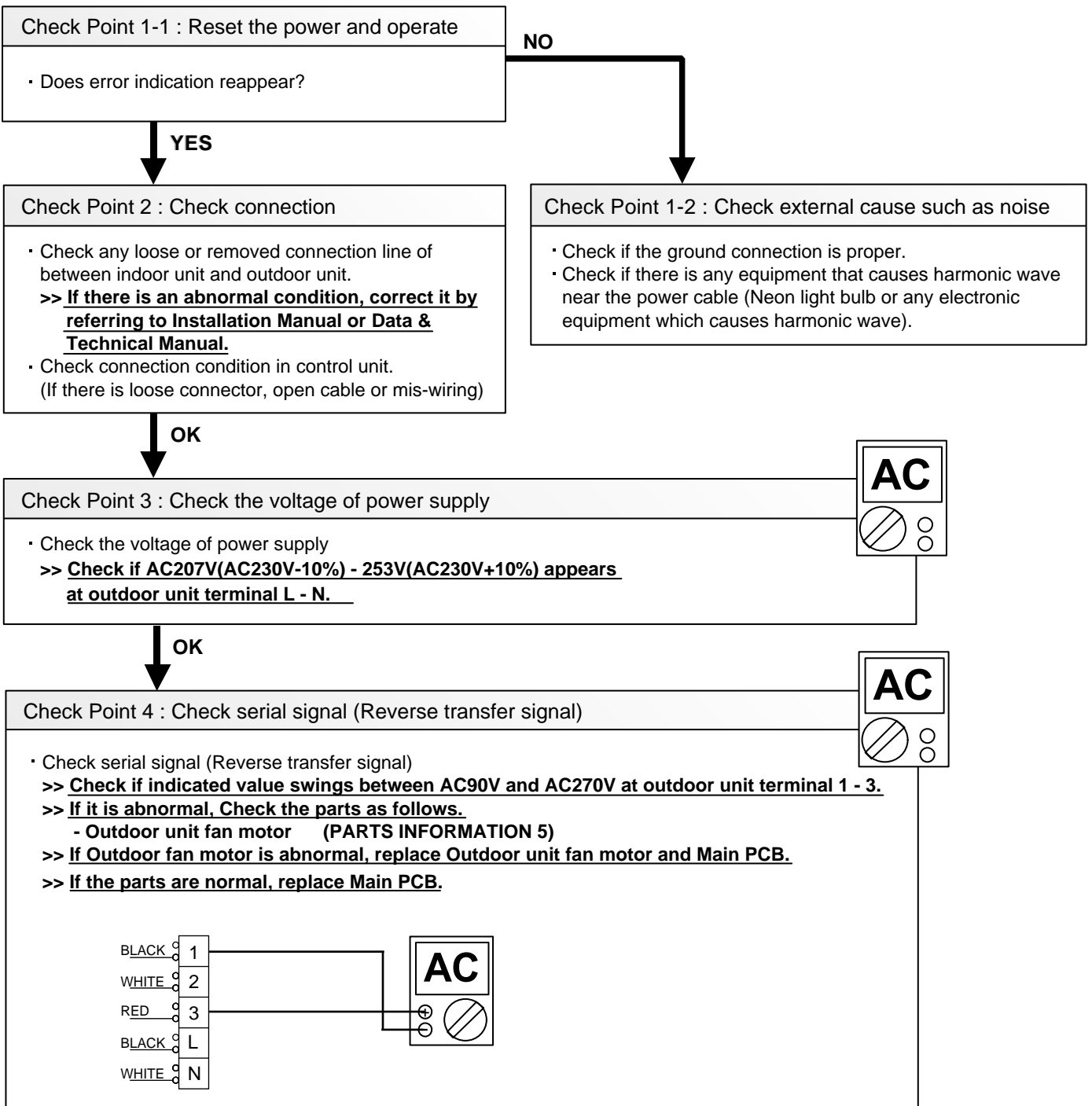

<b>Trouble shooting 2</b> <b>INDOOR UNIT Error Method:</b> <b>Serial Communication Error</b> <b>(Serial Forward Transfer Error)</b>	<b>Indicate or Display:</b> Indoor Unit : Operation indicator: 1 time Flash Timer indicator : 1 time Flash Economy indicator: Continuous Flash Error code: [ E: 11 ]
--	---

<b>Detective Actuators:</b> Indoor unit Controller PCB Indoor unit Fan motor Outdoor unit Main PCB	<b>Detective details:</b> When the outdoor unit cannot properly receive the serial signal from indoor unit for 10 seconds or more.
---	---

**Forecast of Cause:**

1. Connection failure   2. External cause   3. Controller PCB failure   4. Indoor unit fan motor failure  
5. Outdoor unit Main PCB

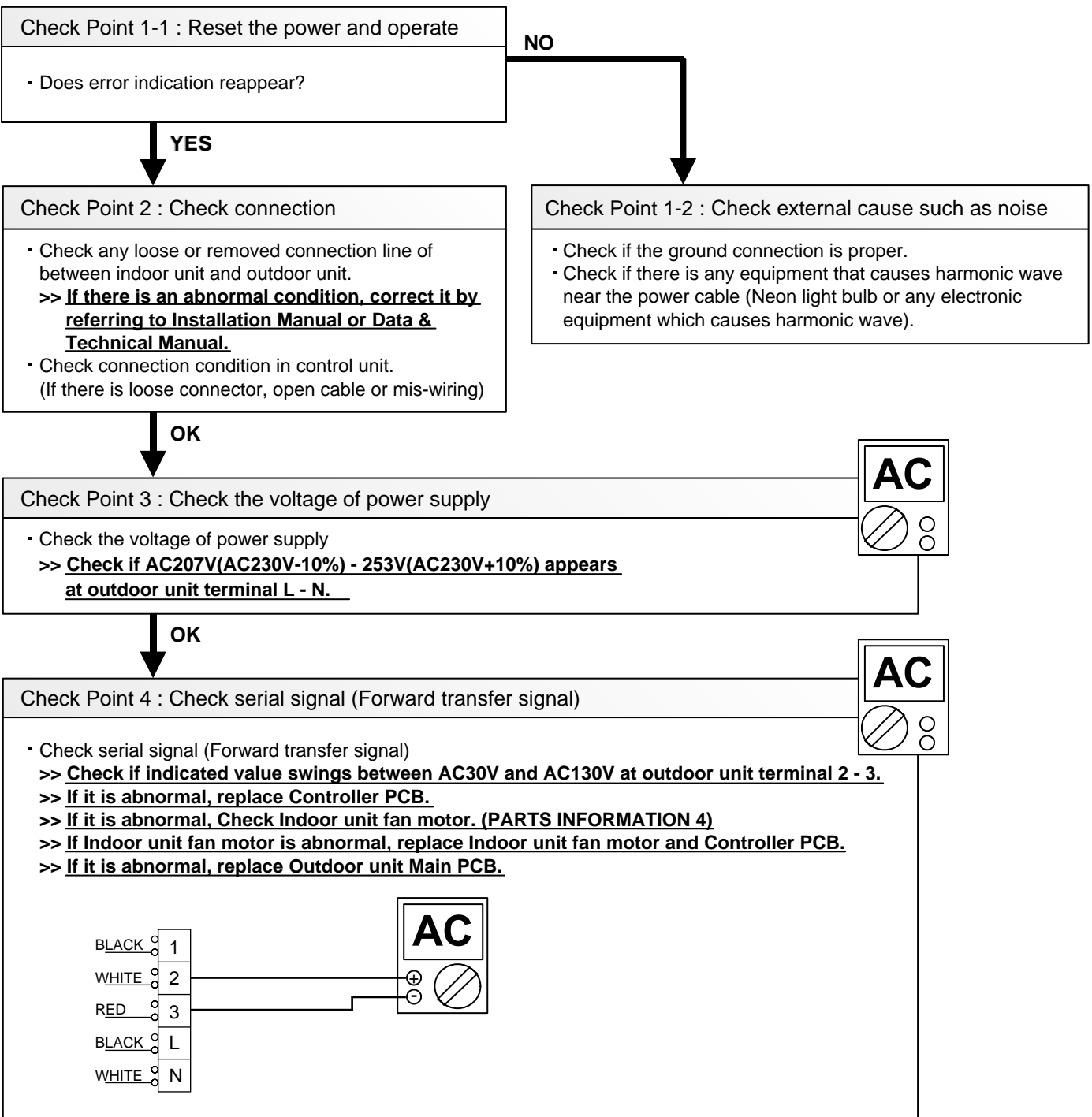

<p><b>Trouble shooting 3</b>  <b><u>OUTDOOR UNIT Error Method:</u></b>  <b>Combination error</b></p>	<p><b><u>Indicate or Display:</u></b>  <b>Indoor Unit :</b>  <b>Operation indicator: 2 time Flash</b>  <b>Timer indicator : 3 time Flash</b>  <b>Economy indicator: Continuous Flash</b>  <b>Error code: [ E: 23 ]</b></p>
--	--

<p><b><u>Detective Actuators:</u></b>  Indoor unit</p>	<p><b><u>Detective details:</u></b>  1. The outdoor unit receives the serial signal of applied refrigerant information from Indoor unit. When the refrigerant is R410a.  2. When the outdoor unit type is multi.</p>
--	--

<p><b><u>Forecast of Cause:</u></b>  1. The selection of indoor units is incorrect</p>
--

<p>Check Point 1 : Check the type of indoor unit</p>
<p>· Check the type of the connected indoor unit.  <u>&gt;&gt; If abnormal condition is found, correct it.</u></p>



<p>Check Point 2 : Replace Main PCB</p>
<p>▶ <u>If Check Point 1 do not improve the symptom, replace Main PCB of Outdoor unit.</u></p>



<b>Trouble shooting 4</b> <b>INDOOR UNIT Error Method:</b> <b>Power Supply Frequency Detection Error</b>	<b>Indicate or Display:</b> Indoor unit: Operation indicator: 3 time Flash Timer indicator : 1 time Flash Economy indicator: Continuous Flash Error code: [ E: 31 ]
--	--

<b>Detective Actuators:</b> Indoor unit Controller PCB Indoor unit Power PCB	<b>Detective details:</b> When power frequency is not detected by 15 seconds after power-on.
--	---

<b>Forecast of Cause:</b> 1. Connection failure    2. External cause    3. Controller PCB failure    4. Power PCB failure
--

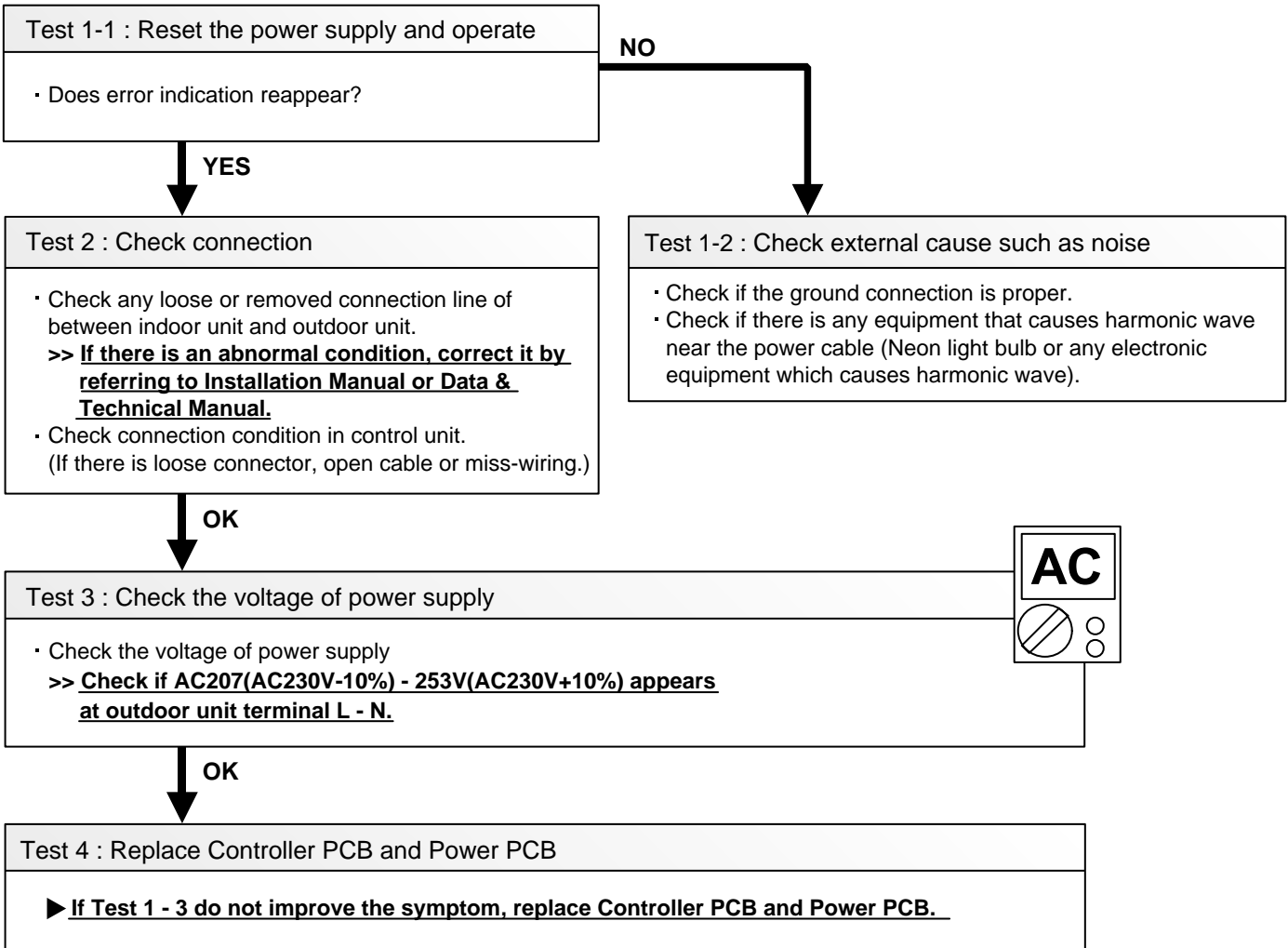

<b>Trouble shooting 5</b> <b><u>INDOOR UNIT Error Method:</u></b> <b>Indoor Unit Model Information Error</b> <b>EEPROM Access Abnormal</b>	<b><u>Indicate or Display:</u></b> Indoor Unit : Operation indicator : 3 time Flash Timer indicator: 2 time Flash Economy indicator: Continuous Flash Error code: [ E: 32 ]
---	--

<b><u>Detective Actuators:</u></b> Indoor unit Controller PCB	<b><u>Detective details:</u></b> When power is on and there is some below case. 1. When model information of EEPROM is incorrect. 2. When the access to EEPROM failed.
--	---

<b><u>Forecast of Cause:</u></b> 1. External cause    2. Defective connection of electric components    3. Controller PCB failure
--

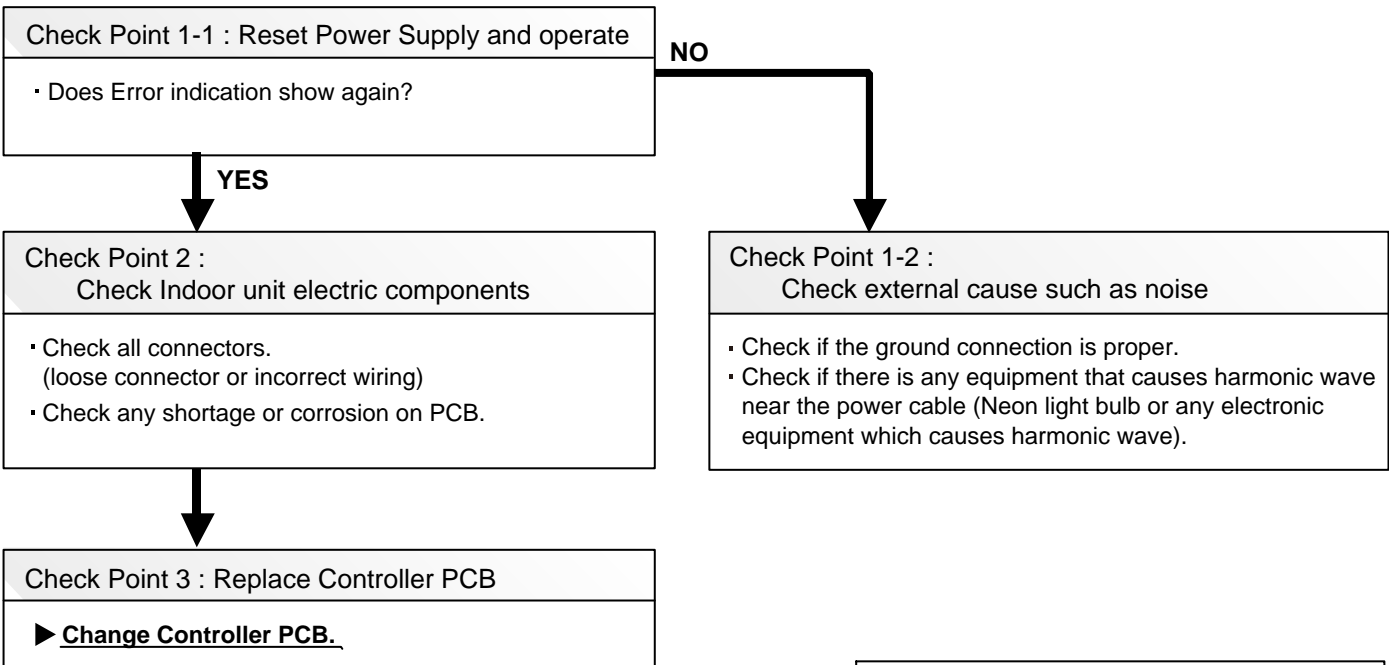



**Note : EEPROM**

EEPROM(Electronically Erasable and Programmable Read Only Memory) is a non-volatile memory which keeps memorized information even if power is turned off. It can change the contents electronically. To change the contents, it uses higher voltage than normal, and it can not change a partial contents. (Rewriting shall be done upon erasing the all contents.) There is a limit in a number of rewriting.

<p><b>Trouble shooting 6</b>  <b><u>INDOOR UNIT Error Method:</u></b>  <b>Manual Auto Switch Error</b></p>	<p><b><u>Indicate or Display:</u></b>  Indoor Unit :  Operation indicator: 3 time Flash  Timer indicator : 5 time Flash  Economy indicator: Continuous Flash  Error code: [ E: 35 ]</p>
--	---

<p><b><u>Detective Actuators:</u></b>  Indoor Unit Controller PCB  Indicator PCB  Manual Auto Switch</p>	<p><b><u>Detective details:</u></b>  When the Manual Auto Switch becomes ON for consecutive 30 or more seconds.</p>
--	---

<p><b><u>Forecast of Cause :</u></b>  1. Manual Auto Switch failure    2. Controller PCB and Indicator PCB failure</p>
--

<p>Check Point 1 : Check the Manual Auto Switch</p>	
<ul style="list-style-type: none"> <li>• Check if Manual Auto Switch is kept pressed.</li> <li>• Check ON/OFF switching operation by using a meter.</li> </ul> <p><b>&gt;&gt; <u>If Manual Auto Switch is disabled (on/off switching), replace it.</u></b></p>	



<p>Check Point 2 : Replace Controller PCB and Indicator PCB</p>
<p><b>▶ <u>If Check Point 1 do not improve the symptom, replace Controller PCB and Indicator PCB and execute the check operation again.</u></b></p>

<b>Trouble shooting 7</b> <b>INDOOR UNIT Error Method:</b> <b>Indoor Room Thermistor Error</b>	<b>Indicate or Display:</b> Indoor Unit : Operation indicator : 4 time Flash Timer indicator : 1 time Flash Economy indicator: Continuous Flash Error code: [ E: 41 ]
--	--

<b>Detective Actuators:</b> Indoor unit Controller PCB Room temperature thermistor	<b>Detective details:</b> When Room temperature thermistor open or short-circuit is detected.
--	--

**Forecast of Cause :** 1. Connector failure connection 2. Thermistor failure 3. Controller PCB failuer

Check Point 1 : Check connection of Connector

- Check if connector is loose or removed
- Check erroneous connection
- Check if thermistor cable is open

**>>Reset Power when reinstalling due to removed connector or incorrect wiring.**



Check Point 2 : Remove connector and check Thermistor resistance value									
Thermistor Characteristics (Rough value)									
Temperature (°C)	-10	-5	0	5	10	15	20	25	
Resistance value (kΩ)	58.3	44.0	33.6	25.9	20.2	15.8	12.5	10.0	
Temperature (°C)	30	35	40	45					
Resistance value (kΩ)	8.0	6.5	5.3	4.4					
<p>► <b>If Thermistor is either open or shorted, replace it and reset the power.</b></p>									



Check Point 3 : Check voltage of Controller PCB (DC5.0V)																		
Make sure circuit diagram of each indoor unit and check terminal voltage at Thermistor (DC5.0V)																		
<div style="display: flex; justify-content: space-between; align-items: center;"> <div style="border: 1px solid black; padding: 5px;"> <table border="1" style="border-collapse: collapse;"> <tr> <td rowspan="2" style="padding: 5px;">CN4</td> <td style="padding: 5px;">1</td> <td style="padding: 5px;">1</td> <td rowspan="2" style="padding: 5px;">BLACK</td> <td rowspan="2" style="text-align: center; padding: 5px;"> </td> <td rowspan="2" style="padding: 5px;">Thermistor(Room Temp.)</td> </tr> <tr> <td style="padding: 5px;">2</td> <td style="padding: 5px;">2</td> <td style="padding: 5px;">BLACK</td> </tr> </table> </div> <div style="text-align: right; padding-right: 20px;"> </div> </div>										CN4	1	1	BLACK		Thermistor(Room Temp.)	2	2	BLACK
CN4	1	1	BLACK		Thermistor(Room Temp.)													
	2	2				BLACK												
<p>► <b>If the voltage does not appear, replace Controller PCB and execute the check operation again.</b></p>																		

<b>Trouble shooting 8</b> <b>INDOOR UNIT Error Method:</b> <b>Indoor Heat Ex. Thermistor Error</b>	<b>Indicate or Display:</b> Indoor Unit : Operation indicator: 4 time Flash Timer indicator : 2 time Flash Economy indicator: Continuous Flash Error code : [ E : 42 ]
--	---

<b>Detective Actuators:</b> Indoor unit Controller PCB Heat exchanger (MID) Thermistor	<b>Detective details:</b> When Heat Ex. temperature thermistor open or short-circuit is detected.
--	--

**Forecast of Cause :** 1. Connector failure connection 2. Thermistor failure 3. Controller PCB failuer

Check Point 1 : Check connection of Connector

- Check if connector is loose or removed
- Check erroneous connection
- Check if thermistor cable is open

**>>Reset Power when reinstalling due to removed connector or incorrect wiring.**



Check Point 2 : Remove connector and check Thermistor resistance value

Thermistor Characteristics (Rough value)

Temperature (°C)	-30	-25	-20	-15	-10	-5	0	5	10	15
Resistance value (kΩ)	1131.9	804.5	579.6	422.9	312.3	233.2	176.0	134.2	103.3	80.3

Temperature (°C)	20	25	30	35	40	45	50	55	60	63
Resistance value (kΩ)	62.9	49.7	39.6	31.7	25.6	20.9	17.1	14.1	11.6	10.4

► **If Thermistor is either open or shorted, replace it and reset the power.**



Check Point 3 : Check voltage of Controller PCB (DC5.0V)

Make sure circuit diagram of each indoor unit and check terminal voltage at Thermistor (DC5.0V)

CN3	1	1	BLACK BLACK Thermistor ( Pipe temp.)
	2	2	

► **If the voltage does not appear, replace Controller PCB and execute the check operation again.**

<b>Trouble shooting 9</b> <b>INDOOR UNIT Error Method:</b> <b>Indoor Fan Motor Lock Error</b> <b>Indoor Fan Motor Rev. Error</b>	<b>Indicate or Display:</b> <b>Indoor Unit :</b> <b>Operation indicator: 5 time Flash</b> <b>Timer indicator : 1 time Flash</b> <b>Economy indicator: Continuous Flash</b> <b>Error code : [ E : 51 ]</b>
---	--

<b>Detective Actuators:</b>  Indoor unit Controller PCB Indoor Fan motor	<b>Detective details:</b>  <ul style="list-style-type: none"> <li>• When the condition that actual rev. of Indoor Fan is 1/3 or less. Or the condition of fan speed is 0rpm is continued more than 56 seconds.</li> <li>• When it detected 10 seconds continuously at the target rotation (200rpm) or more.</li> </ul>
---	--

<b>Forecast of Cause:</b>  1. Fan motor failure    2. Motor protection by surrounding temperature rise 3. Controller PCB failure
---

<b>Test 1 : Check rotation of Fan</b>
<ul style="list-style-type: none"> <li>• Check if the Fan Motor is lock. (Can the Fan be rotated by hand when operation is off.)</li> <li>• Check the Fan loosening. (Lock-nut loosening, defective propeller fan)</li> </ul> <b>&gt;&gt; If Fan Motor or bearing is abnormal, replace it.</b>

↓ **OK**

<b>Test 2 : Check ambient temp. around motor</b>
<ul style="list-style-type: none"> <li>• Check excessively high temperature around the motor. (If there is any surrounding equipment that causes heat)</li> </ul> <b>&gt;&gt; Upon the temperature coming down, restart operation.</b>

↓ **OK**

<b>Test 3 : Check Indoor unit Fan motor</b>
Check Indoor unit Fan motor. ( SERVICE PARTS INFORMATION 4 )

↓ **OK**

<b>Test 4 : Replace Controller PCB</b>
<b>▶ If Test 1, 2 do not improve the symptom, replace Controller PCB.</b>

<b>Trouble shooting 10</b> <b><u>INDOOR UNIT Error Method:</u></b> <b>Plasma air clean unit Vdd Error</b>	<b><u>Indicate or Display:</u></b> <b>Indoor Unit :</b> <b>Operation indicator: 5 time Flash</b> <b>Timer indicator : 4 time Flash</b> <b>Economy indicator: Continuous Flash</b> <b>Error code : [ E : 54 ]</b>
---	---

<b><u>Detective Actuators:</u></b>  Plasma air clean unit is defect Indoor unit controller PCB defect	<b><u>Detective details:</u></b>  • The air clean operation signal was detected for 1 minute at the time of air clean mode OFF.
--	---

<b><u>Forecast of Cause:</u></b> 1. Plasma air clean unit is defect 2. Indoor unit controller PCB defect
--

Check 1 : is the front panel completely closed and in the right position?  
---



Check 2 : some foreign body's such as dust doesn't adhere,  - the air clean unit has no good contact - the wiring between pcb and air clean unit is loose If there is no any abnormality Replace: the Plasma air clean unit is defect /Indoor unit controller PCB.
---

<b>Trouble shooting 11</b> <b><u>INDOOR UNIT Error Method:</u></b> <b>Filter set abnormal</b>	<b><u>Indicate or Display:</u></b> Indoor Unit : Operation indicator : 5 time Flash Timer indicator : 5 time Flash Economy indicator: Continuous Flash Error code : [ E : 55 ]
---	---

<b><u>Detective Actuators:</u></b>  Limit SW Filter	<b><u>Detective details:</u></b>  • When the filter set position was wrong.
--	---

<b><u>Forecast of Cause:</u></b> 1. Filter set position 2. Limit SW
---

Check 1 : Filter set position
Set position: Refer to the operation manual



Check 2 : Intake grille closed completely
Make sure that the Intake grille is closed completely



<b>Trouble shooting 12</b> <b>INDOOR UNIT Error Method:</b> <b>Side Fan Motor ( Left ) Lock Error</b> <b>Side Fan Motor ( Left ) Rev. Error</b>	<b>Indicate or Display:</b> Indoor Unit : Operation indicator: 5 time Flash Timer indicator : 9 time Flash Economy indicator: Continuous Flash Error code: [ E : 59 ]
--	--

<b>Detective Actuators:</b> Indoor unit Controller PCB Indoor Side Fan motor ( Left )	<b>Detective details:</b> <ul style="list-style-type: none"> <li>• When the condition that actual rev. of Indoor Fan is 1/3 or less. Or the condition of fan speed is 0rpm is continued more than 56 seconds.</li> <li>• When it detecteds 10 seconds continuously at the target rotation (200rpm) or more.</li> </ul>
---	---

**Forecast of Cause:**

1. Fan motor failure
2. Motor protection by surrounding temperature rise
3. Controller PCB failure

**Test 1 : Check connection of connector**

- Check if connector is removed.
- Check if connector is erroneous connection.
- Check if thermistor cable is open.

>> **Upon correcting the removed connector or miss-wiring, reset the power.**



<b>Test 2 : Remove connector and Check Controller PCB side connector voltage value</b>	<div style="border: 1px solid black; padding: 5px; display: inline-block;"> <b>DC</b>  </div>									
<p>Make sure circuit diagram of indoor unit and check connector voltage at Controller PCB.  Remove the CN28 of Controller PCB.  ( Please before the remove the connector, power supply switch OFF . Then turn ON.)</p>										
<div style="border: 1px solid black; padding: 10px;"> <p style="text-align: center;">SIDE FAN MOTOR ( LEFT )</p> </div>	<table border="1" style="width: 100%; text-align: center;"> <thead> <tr> <th>Tester (+)</th> <th>Tester (-)</th> <th>Voltage Value</th> </tr> </thead> <tbody> <tr> <td>1 pin</td> <td>4 pin</td> <td>0V</td> </tr> <tr> <td>5 pin</td> <td>4 pin</td> <td>20V</td> </tr> </tbody> </table>	Tester (+)	Tester (-)	Voltage Value	1 pin	4 pin	0V	5 pin	4 pin	20V
Tester (+)	Tester (-)	Voltage Value								
1 pin	4 pin	0V								
5 pin	4 pin	20V								
<p>▶ <b>If the measurement value does not match the above table , replace the Controller PCB.</b></p>										



**Test 3 : Replace Side Fan**

▶ **If Test 1, 2 do not improve the symptom , replace Side Fan.**

<b>Trouble shooting 13</b> <b>INDOOR UNIT Error Method:</b> <b>Side Fan Motor ( Right ) Lock Error</b> <b>Side Fan Motor ( Right ) Rev. Error</b>	<b>Indicate or Display:</b> <b>Indoor Unit :</b> <b>Operation indicator: 5 time Flash</b> <b>Timer indicator : 10 time Flash</b> <b>Economy indicator: Continuous Flash</b> <b>Error code : [ E : 5A ]</b>
--	---

<b>Detective Actuators:</b> Indoor unit Controller PCB Indoor Side Fan motor ( Right )	<b>Detective details:</b> <ul style="list-style-type: none"> <li>• When the condition that actual rev. of Indoor Fan is 1/3 or less. Or the condition of fan speed is 0rpm is continued more than 56 seconds.</li> <li>• When it detecteds 10 seconds continuously at the target rotation (200rpm) or more.</li> </ul>
--	--

**Forecast of Cause:**

1. Fan motor failure
2. Motor protection by surrounding temperature rise
3. Controller PCB failure

**Test 1 : Check connection of connector**

- Check if connector is removed.
- Check if connector is erroneous connection.
- Check if thermistor cable is open.

**>> Upon correcting the removed connector or miss-wiring, reset the power.**



**DC**

**Test 2 : Remove connector and Check Controller PCB side connector voltage value**

Make sure circuit diagram of indoor unit and check connector voltage at Controller PCB.  
 Remove the CN25 of Controller PCB.  
 ( Please before the remove the connector, power supply switch OFF . Then turn ON.)

Tester (+)	Tester (-)	Voltage Value
1 pin	4 pin	0V
2 pin	4 pin	20V
5 pin	4 pin	20V

**► If the measurement value does not match the above table , replace the Controller PCB.**



**Test 3 : Replace Side Fan**

**► If Test 1, 2 do not improve the symptom , replace Side Fan.**

<p><b>Trouble shooting 14</b>  <b><u>OUTDOOR UNIT Error Method:</u></b>  <b>Outdoor unit main PCB model information error</b></p>	<p><b><u>Indicate or Display:</u></b>  Indoor Unit :  <b>Operation indicator: 6 time Flash</b>  <b>Timer indicator : 2 time Flash</b>  <b>Economy indicator: Continuous Flash</b>  <b>Error code: [ E : 62 ]</b></p>
---	--

<p><b><u>Detective Actuators:</u></b>  Outdoor unit Main PCB</p>	<p><b><u>Detective details:</u></b>  Access to EEPROM failed due to some cause after outdoor unit started.</p>
--	--

<p><b><u>Forecast of Cause:</u></b>  1. External cause (Noise, temporary open, voltage drop)    2. Main PCB failure</p>
---

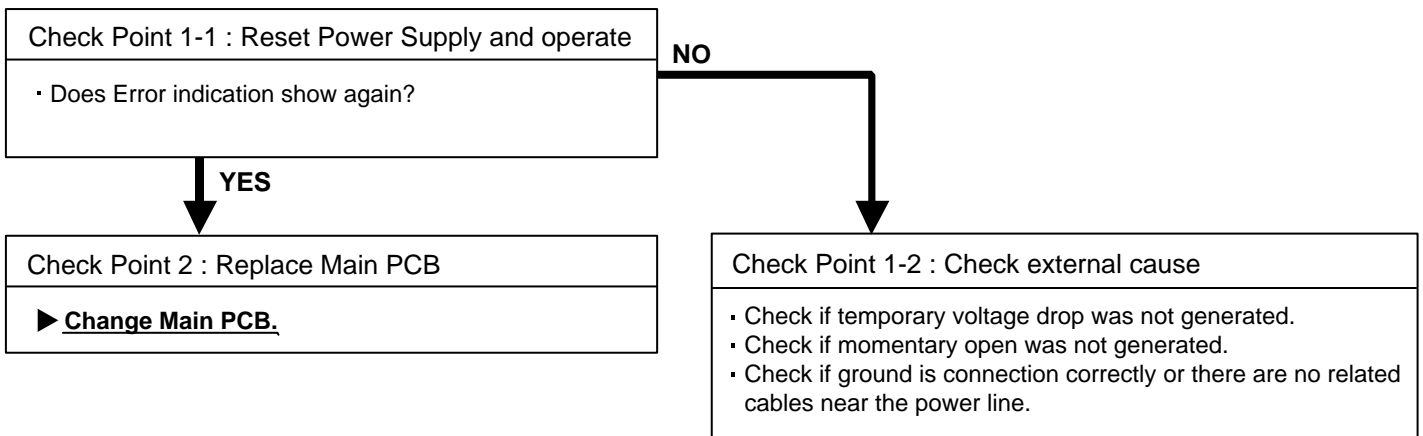

<p><b>Trouble shooting 15</b>  <b><u>OUTDOOR UNIT Error Method:</u></b>  <b>Trip terminal L error</b></p>	<p><b><u>Indicate or Display:</u></b>  <b>Indoor Unit :</b>  <b>Operation indicator : 6 time Flash</b>  <b>Timer indicator : 5 time Flash</b>  <b>Economy indicator: Continuous Flash</b>  <b>Error code : [ E : 65 ]</b></p>
---	---

<p><b><u>Detective Actuators:</u></b>  Outdoor unit Main PCB</p>	<p><b><u>Detective details:</u></b>  When the signal from FO terminal of IPM in Main PCB is "L"(=0V) while the compressor stops.</p>
--	--

<p><b><u>Forecast of Cause :</u></b>  1. Main PCB failure</p>
---

<p>Check Point 1 : Replace Main PCB</p>
<p>▶ <b><u>Change Main PCB.</u></b></p>

<b>Trouble shooting 16</b> <b>OUTDOOR UNIT Error Method:</b> <b>Discharge Thermistor Error</b>	<b>Indicate or Display:</b> <b>Indoor Unit :</b> <b>Operation indicator: 7 time Flash</b> <b>Timer indicator : 1 time Flash</b> <b>Economy indicator: Continuous Flash</b> <b>Error code : [ E : 71 ]</b>
--	--

<b>Detective Actuators:</b> Outdoor unit Main PCB Discharge pipe temperature thermistor	<b>Detective details:</b> When Discharge pipe temperature thermistor open or short-circuit is detected at power ON or while running the compressor.
---	--

**Forecast of Cause :**  
 1. Connector connection failure   2. Thermistor failure   3. Main PCB failure

**Check Point 1 : Check connection of connector**

- Check if connector is removed.
- Check if connector is erroneous connection.
- Check if thermistor cable is open.

**>> Upon correcting the removed connector or mis-wiring, reset the power.**



**Check Point 2 : Remove connector and check thermistor resistance value**

Thermistor characteristics (Approx. value)

Temperature (°C)	-30	-20	-10	-5	0	5	10	15	20
Resistance value (kΩ)	1013.1	531.6	292.9	221.1	168.6	129.8	100.9	79.1	62.6

Temperature (°C)	30	40	50	60	70	80	90	100	120
Resistance value (kΩ)	40.0	26.3	17.8	12.3	8.7	6.3	4.6	3.4	2.0

**► If Thermistor is either open or shorted, replace it and reset the power.**



**Check Point 3 : Check voltage of Main PCB (DC5.0V)**

Make sure circuit diagram of outdoor unit and check terminal voltage at thermistor (DC5.0V)

P1

1 BLACK

2 BLACK

3 BLACK

4 BLACK

Thermistor (DISCHARGE PIPE)

**► If the voltage does not appear, replace Main PCB.**

<b>Trouble shooting 17</b> <b>OUTDOOR UNIT Error Method:</b> <b>Heat Ex. Liquid Outlet Thermistor Error</b>	<b>Indicate or Display:</b> <b>Indoor Unit :</b> Operation indicator: 7 time Flash Timer indicator : 3 time Flash Economy indicator: Continuous Flash Error code: [ E : 73 ]
---	---

<b>Detective Actuators:</b> Outdoor unit Main PCB Heat exchanger temperature thermistor	<b>Detective details:</b> When Heat exchanger temperature thermistor open or short-circuit is detected at power ON or while running the compressor.
---	--

Forecast of Cause :  
 1. Connector connection failure 2. Thermistor failure 3. Main PCB failure

Check Point 1 : Check connection of connector

- Check if connector is removed.
- Check if connector is erroneous connection.
- Check if thermistor cable is open.

**>> Upon correcting the removed connector or mis-wiring, reset the power.**



Check Point 2 : Remove connector and check thermistor resistance value

Thermistor characteristics (Approx. value)

Temperature (°C)	-30	-20	-10	-5	0	5	10	15
Resistance value (kΩ)	92.3	49.2	27.5	20.9	16.1	12.4	9.7	7.7

Temperature (°C)	20	30	40	50	60	70	80	90
Resistance value (kΩ)	6.1	4.0	2.6	1.8	1.3	0.9	0.7	0.5

**► If Thermistor is either open or shorted, replace it and reset the power.**



Check Point 3 : Check voltage of Main PCB (DC5.0V)

Make sure circuit diagram of outdoor unit and check terminal voltage at thermistor (DC5.0V)

P1

1 1 BLACK Thermistor (PIPE temp.)

2 2 BLACK

3 3 BLACK

4 4 BLACK

**► If the voltage does not appear, replace Main PCB.**

<b>Trouble shooting 18</b> <b>OUTDOOR UNIT Error Method:</b> <b>Outdoor Thermistor Error</b>	<b>Indicate or Display:</b> <b>Indoor Unit :</b> <b>Operation indicator : 7 times Flash</b> <b>Timer indicator : 4 times Flash</b> <b>Economy indicator: Continuous Flash</b> <b>Error code : [ E: 74 ]</b>
--	--

<b>Detective Actuators:</b> Outdoor unit Main PCB Outdoor temperature thermistor	<b>Detective details:</b> When Outdoor temperature thermistor open or short-circuit is detected at power ON or while running the compressor.
--	---

**Forecast of Cause :**  
 1. Connector connection failure 2. Thermistor failure 3. Main PCB failure

**Check Point 1 : Check connection of connector**

- Check if connector is removed.
- Check if connector is erroneous connection.
- Check if thermistor cable is open.

**>> Upon correcting the removed connector or mis-wiring, reset the power.**

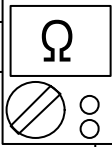

**Check Point 2 : Remove connector and check thermistor resistance value** 

Thermistor characteristics (Approx. value)

Temperature (°C)	-30	-20	-10	-5	0	5	10	15
Resistance value (kΩ)	224.3	115.2	62.3	46.6	35.2	26.9	20.7	16.1

Temperature (°C)	20	30	40	50	60	70	80
Resistance value (kΩ)	12.6	8.0	5.2	3.5	2.4	1.7	1.2

**► If Thermistor is either open or shorted, replace it and reset the power.**



**Check Point 3 : Check voltage of Main PCB (DC5.0V)** 

Make sure circuit diagram of outdoor unit and check terminal voltage at thermistor (DC5.0V)

**► If the voltage does not appear, replace Main PCB.**

<b>Trouble shooting 19</b> <b>OUTDOOR UNIT Error Method:</b> <b>Current Sensor Error</b>	<u><b>Indicate or Display:</b></u> <b>Indoor Unit :</b> <b>Operation Indicator: 8 times Flash</b> <b>Timer indicator : 4 times Flash</b> <b>Economy indicator: Continuous Flash</b> <b>Error code: [ E : 84 ]</b>
--	--

<u><b>Detective Actuators:</b></u> Outdoor unit Main PCB	<u><b>Detective details:</b></u> When input current sensor has detected 0A, while Inverter compressor is operating at higher than 56rps, after 1 minute upon starting the compressor. (Except during the defrost operation)
---	--

<u><b>Forecast of Cause :</b></u> 1. Defective connection of electric components    2. External cause    3. Main PCB failure
---

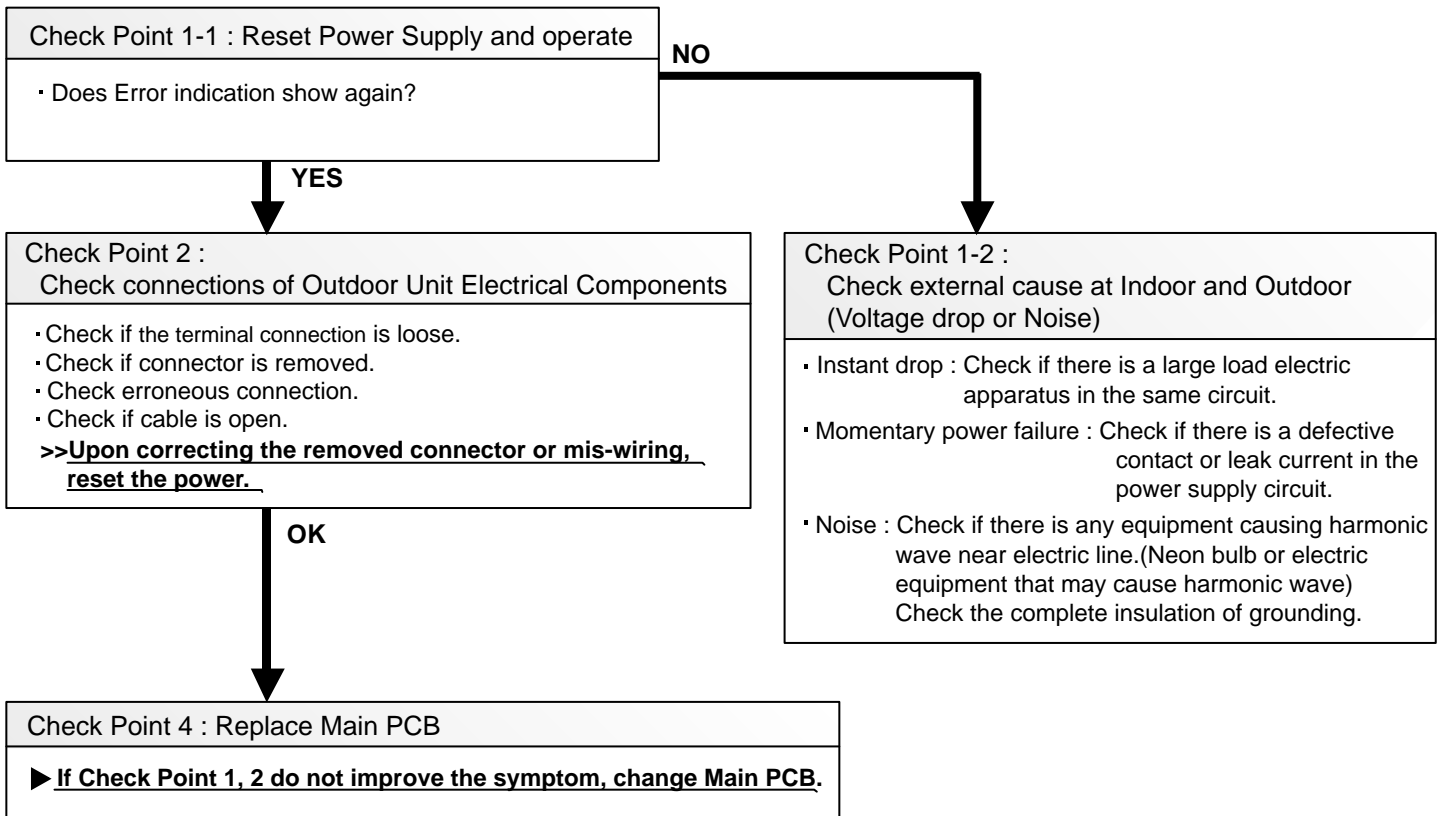



<p><b>Trouble shooting 20</b>  <b>OUTDOOR UNIT Error Method:</b>  <b>High Pressure Switch Error</b></p>	<p><b>Indicate or Display:</b>  Indoor Unit :  Operation indicator : 8 times Flash  Timer indicator : 6 times Flash  Economy indicator: Continuous Flash  Error code: [ E : 86 ]</p>
---	--

<p><b>Detective Actuators:</b>  Outdoor unit Main PCB  High Pressure Switch</p>	<p><b>Detective details:</b>  When pressure switch open is detected in 10 seconds after the power is turned on.</p>
---	---

<p><b>Forecast of Cause :</b></p> <ol style="list-style-type: none"> <li>1. High pressure switch connector disconnection, open</li> <li>2. High pressure switch characteristics failure</li> <li>3. Main PCB failure</li> </ol>
---

<p>Check Point 1 : Check the high pressure switch connection state</p>
<ul style="list-style-type: none"> <li>• Connector and wiring connection state check</li> <li>• Cable open check</li> </ul>



<p>Check Point 2 : Check the high pressure switch characteristics</p>
<ul style="list-style-type: none"> <li>• Switch characteristics check</li> <li>* For the characteristics of high pressure switch, refer to below.</li> </ul>



<p>Check Point 3 : Replace Main PCB</p>
<ul style="list-style-type: none"> <li>• <b>Change Main PCB, and execute the check operation again.</b></li> </ul>

• Type of contact

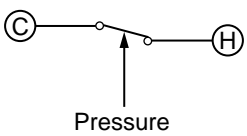

• Characteristics of pressure switch (Connector: P20)

	Pressure switch 1
Contact : Short ⇒ Open	4.2±0.1MPa
Contact : Open ⇒ Short	3.2±0.15MPa

<b>Trouble shooting 21</b> <b>OUTDOOR UNIT Error Method:</b> <b>Trip detection</b>	<b>Indicate or Display:</b> <b>Indoor Unit :</b> <b>Operation indicator : 9 times Flash</b> <b>Timer indicator: 4 times Flash</b> <b>Economy indicator: Continuous Flash</b> <b>Error code : [ E : 94 ]</b>
--	--

<b>Detective Actuators:</b>  Outdoor unit Main PCB Compressor	<b>Detective details:</b> <ul style="list-style-type: none"> <li>▪ "Protection stop by overcurrent generation after inverter compressor start processing completed" generated consecutively 10 times.</li> <li>* The number of generations is reset if the start-up of the compressor succeeds.</li> </ul>
--	---

<b>Forecast of Cause :</b> <ol style="list-style-type: none"> <li>1. Outdoor unit fan operation defective, foreign matter on hear exchanger, excessive rise of ambient temperature</li> <li>2. Main PCB</li> <li>3. Inverter compressor failure (lock, winding short)</li> </ol>
--

<b>Check Point 1 : Check the outdoor unit fan operation, heat exchanger, ambient temperature</b>
<ul style="list-style-type: none"> <li>▪ No obstructions in air passages?</li> <li>▪ Heat exchange fins clogged</li> <li>▪ Outdoor unit fan motor check</li> <li>▪ Ambient temperature not raised by the effect of other heat sources?</li> <li>▪ Discharged air not sucked in?</li> </ul>

↓ **OK**

<b>Check Point 2: Check IPM on the Main PCB</b>
<ul style="list-style-type: none"> <li>▪ Check IPM. (<b>PARTS INFORMATION 6</b>)</li> <li><b>&gt;&gt; If IPM is abnormal, replace Main PCB.</b></li> </ul>

↓ **OK**

<b>Check Point 3: Replace Compressor</b>
<b>▶ If Check Point 2 do not improve the symptom, change Compressor.</b>

<b>Trouble shooting 22</b> <b><u>OUTDOOR UNIT Error Method:</u></b> <b>Compressor Control Error</b>	<b><u>Indicate or Display:</u></b> <b>Indoor Unit :</b> <b>Operation indicator : 9 times Flash</b> <b>Timer indicator: 5 times Flash</b> <b>Economy indicator: Continuous Flash</b> <b>Error code : [ E : 95 ]</b>
---	---

<b><u>Detective Actuators:</u></b>  Outdoor unit Main PCB Compressor	<b><u>Detective details:</u></b>  ① While running the compressor, if the detected rotor location is out of phase with actual rotor location more than 90°, the compressor stops. ② After the compressor restarts, if the same operation is repeated within 40sec, the compressor stops again. ③ If ① and ② repeats 5 times, the compressor stops permanently.
---	---

<b><u>Forecast of Cause :</u></b>  1. Defective connection of electric components    2. Main PCB failure    3. Compressor failure
---

Check Point 1 : Check Noise from Compressor  · Turn on Power and check operation noise. ▶ <b><u>If an abnormal noise show, replace Compressor.</u></b>
---



Check Point 2 : Check connection of around the Compressor components  For Compressor Terminal, Main PCB · Check if connector is removed. · Check erroneous connection. · Check if cable is open. (Refer to PARTS INFORMATION 2) >> <b><u>Upon correcting the removed connector or mis-wiring, reset the power.</u></b>
---



Check Point 3: Check Main PCB (IPM)  · Check IPM. (PARTS INFORMATION 6) >> <b><u>If IPM is abnormal, replace Main PCB.</u></b>
---



Check Point 4: Replace Main PCB  ▶ <b><u>If Check Point 1,2 or 1~3 do not improve the symptom, change Main PCB.</u></b>
---



Check Point 5: Replace Compressor  ▶ <b><u>If Check Point 4 do not improve the symptom, change Compressor.</u></b>
--

<p><b>Trouble shooting 23</b>  <b><u>OUTDOOR UNIT Error Method:</u></b>  <b>Outdoor Unit Fan Motor Error</b></p>	<p><b><u>Indicate or Display:</u></b>  <b>Indoor Unit :</b>  <b>Operation indicator : 9 times Flash</b>  <b>Timer indicator : 7 times Flash</b>  <b>Economy indicator: Continuous Flash</b>  <b>Error code : [ E : 97 ]</b></p>
--	---

<p><b><u>Detective Actuators:</u></b>  Outdoor unit Main PCB  Outdoor unit fan motor</p>	<p><b><u>Detective details:</u></b></p> <ol style="list-style-type: none"> <li>① When outdoor fan rotation speed is less than 100rpm in 20 seconds after fan motor starts, fan motor stops.</li> <li>② After fan motor restarts, if the same operation within 60sec is repeated 3 times in a row, compressor and fan motor stops.</li> <li>③ If ① and ② repeats 5 times in a row, compressor and fan motor stops permanently.</li> </ol>
--	--

<p><b><u>Forecast of Cause:</u></b></p> <ol style="list-style-type: none"> <li>1. Fan rotation failure</li> <li>2. Motor protection by surrounding temperature rise</li> <li>3. Main PCB failure</li> <li>4. Outdoor unit fan motor failure</li> </ol>
--

<p><b>Check Point 1 : Check rotation of Fan</b></p> <ul style="list-style-type: none"> <li>• Rotate the fan by hand when operation is off.  (Check if fan is caught, dropped off or locked motor)</li> </ul> <p><b>&gt;&gt;<u>If Fan or Bearing is abnormal, replace it.</u></b></p>
--

↓  
OK

<p><b>Check Point 2 : Check ambient temp. around motor</b></p> <ul style="list-style-type: none"> <li>• Check excessively high temperature around the motor.  (If there is any surrounding equipment that causes heat)</li> </ul> <p><b>&gt;&gt;<u>Upon the temperature coming down, restart operation.</u></b></p>
---

↓  
OK

<p><b>Check Point 3 : Check Outdoor unit fan motor</b></p> <ul style="list-style-type: none"> <li>• Check Outdoor unit fan motor. <b>(PARTS INFORMATION 5)</b></li> </ul> <p><b>&gt;&gt;<u>If Outdoor Fan Motor is abnormal, replace Outdoor fan motor and Main PCB.</u></b></p>
--

↓  
OK

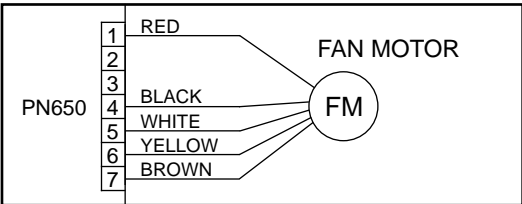
<p><b>Check Point 4 : Check Output Voltage of Main PCB</b></p> <ul style="list-style-type: none"> <li>• Check outdoor unit circuit diagram and the voltage. (Measure at Main PCB side connector)</li> </ul> <div style="text-align: right; margin-bottom: 10px;">  </div> <div style="margin-bottom: 10px;">  </div> <table border="1" style="margin-bottom: 10px;"> <tr> <td>Read wire</td> <td>DC voltage</td> </tr> <tr> <td>Red - Black</td> <td>240 ~ 400V</td> </tr> <tr> <td>White - Black</td> <td>15 ±1.5V</td> </tr> </table> <p><b>▶ <u>If the voltage is not correct, replace Main PCB.</u></b></p>	Read wire	DC voltage	Red - Black	240 ~ 400V	White - Black	15 ±1.5V
Read wire	DC voltage					
Red - Black	240 ~ 400V					
White - Black	15 ±1.5V					

<b>Trouble shooting 24</b> <b>OUTDOOR UNIT Error Method:</b> <b>4-Way Valve Error</b>	<b>Indicate or Display:</b> Indoor Unit : <b>Operation indicator : 9 times Flash</b> <b>Timer indicator : 9 times Flash</b> <b>Economy indicator: Continuous Flash</b> <b>Error code : [ E : 99 ]</b>
---	--

<b>Detective Actuators:</b> Indoor unit Controller PCB Heat Ex. temperature thermistor Room temperature thermistor 4-way valve	<b>Detective details:</b> When the indoor heat exchanger temperature is compared with the room temperature, and either following condition is detected continuously two times, the compressor stops. <ul style="list-style-type: none"> <li>▪ Cooling or Dry operation  [Indoor heat exchanger temp.] - [Room temp.] &gt; 10°C</li> <li>▪ Heating operation  [Indoor heat exchanger temp.] - [room temp.] &lt; -10°C</li> </ul> If the same operation is repeated 5 times, the compressor stops permanently.
--	---

<b>Forecast of Cause :</b> 1. Air filter clogged    2. Connector connection failure    3. Thermistor failure    4. Coil failure 5. 4-way valve failure    6. Controller PCB failure
---

<b>Check Point 1 : Check the Air filter condition</b>
<ul style="list-style-type: none"> <li>• Check is Air filter dirty.</li> </ul> <b>&gt;&gt; If the Air filter dirty, clean up the Air filter.</b>



<b>Check Point 2 : Check connection of Connector</b>
<ul style="list-style-type: none"> <li>• Check if connector is removed.</li> <li>• Check erroneous connection.</li> <li>• Check if thermistor cable is open.</li> </ul> <b>&gt;&gt; Upon correcting the removed connector or mis-wiring, reset the power.</b>



<b>Check Point 3 : Check each thermistor</b>
<ul style="list-style-type: none"> <li>• Isn't it fallen off the holder?</li> <li>• Is there a cable pinched?</li> </ul> <b>&gt;&gt; Check characteristics of thermistor (Refer to Trouble shooting 7, 8),  If defective, replace the thermistor</b>



<b>Check Point 4 : Check the solenoid coil and 4-way valve</b>
[ Solenoid coil ] <ul style="list-style-type: none"> <li>• Remove CN30 from PCB and check the resistance value of coil.  Resistance value is 2.085Ω (at 20°C).</li> </ul> <b>&gt;&gt; If it is Open or abnormal resistance value, replace Solenoid Coil.</b>
[ 4-way valve ] <ul style="list-style-type: none"> <li>• Check each piping temperature,  and the location of the valve by the temperature difference.</li> </ul> <b>&gt;&gt; If the value location is not proper, replace 4-way valve.</b>



<b>Check Point 5 : Replace Controller PCB</b>
<b>▶ If Check Point 1- 3 do not improve the symptom, replace Controller PCB.</b>

<b>Trouble shooting 25</b> <b>OUTDOOR UNIT Error Method:</b> <b>Discharge Temp. Error</b>	<b>Indicate or Display:</b> <b>Indoor Unit :</b> <b>Operation indicator : 10 times Flash</b> <b>Timer indicator : 1 times Flash</b> <b>Economy indicator: Continuous Flash</b> <b>Error code : [ E : A1 ]</b>
---	--

<b>Detective Actuators:</b> Discharge temperature thermistor Outdoor unit Main PCB	<b>Detective details:</b> <ul style="list-style-type: none"> <li>"Protection stop by "discharge temperature <math>\geq</math> 110degC during compressor operation"" generated 2 times within 24 hours.</li> </ul>
--	--

<b>Forecast of Cause :</b>	1. 3-way valve not opened 2. EEV defective, strainer clogged 3. Outdoor unit operation failure, foreign matter on heat exchanger 4. Discharge temperature thermistor failure 5. Insufficient refrigerant 6. Main PCB failure
----------------------------	---

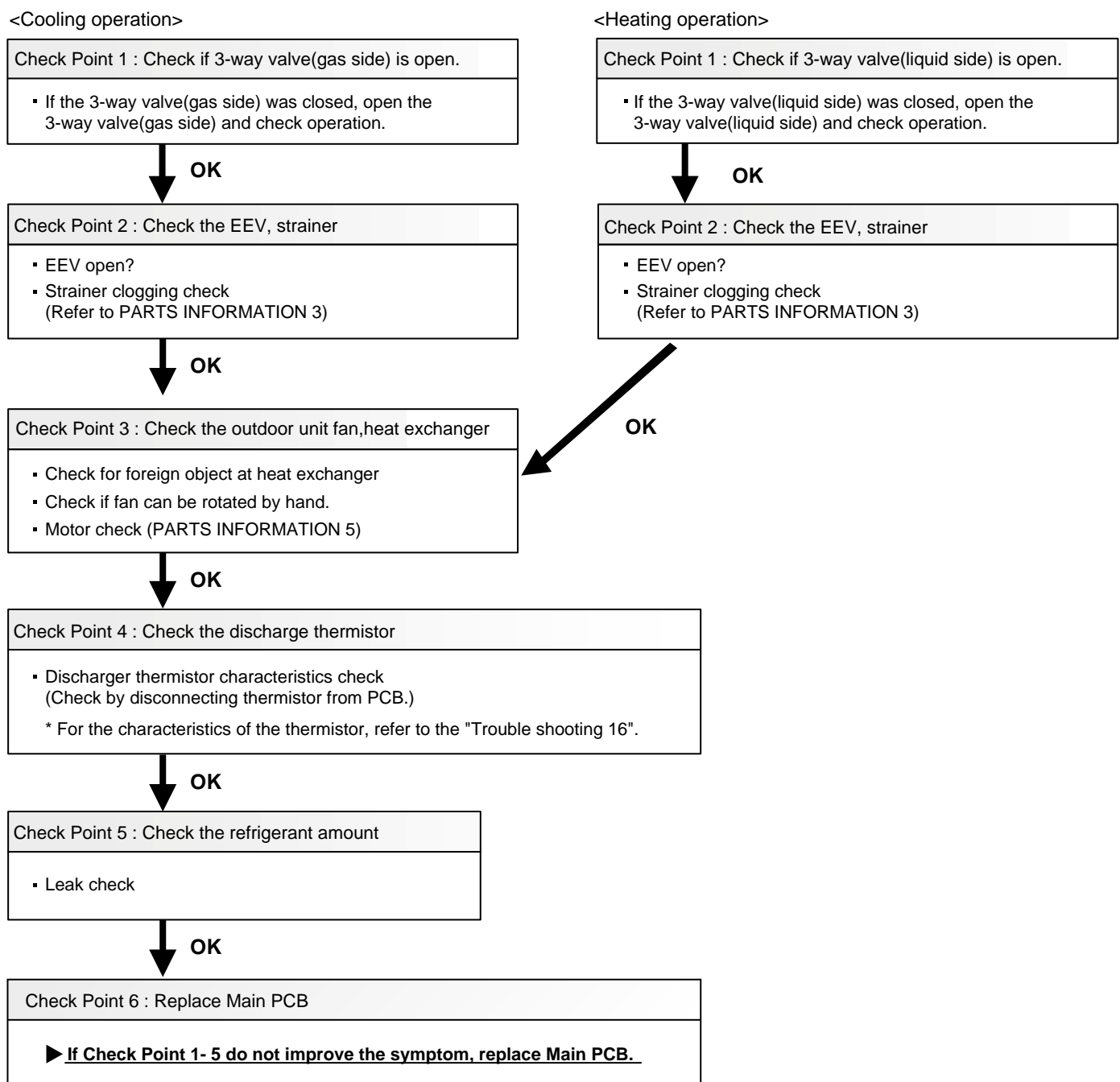

<p><b>Trouble shooting 26</b>  <b>INDOOR UNIT Error Method:</b>  <b>External Communication Error</b>          (Communication Error of between Indoor unit to Wireless LAN adapter)</p>	<p><b>Indicate of Display:</b>  <b>Indoor Unit :</b>  <b>Operation indicator: 1 times Flash</b>  <b>Timerindicator : 8 times Flash</b>  <b>Economy indicator: Continuous Flash</b>  <b>Error code: [ E : 18 ]</b></p> <p><b>Wireless LAN adapter :</b>  <b>LED 1 (Green) : Flashing Fast</b>  <b>LED 2 (Orange) : ON</b></p>
--	--

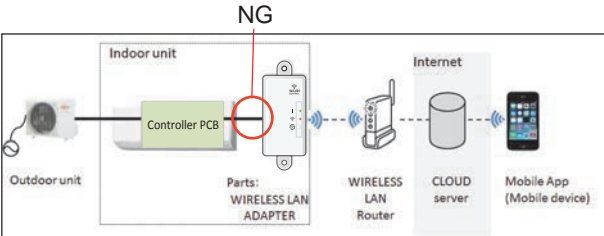
<p><b>Detective Actuators:</b>          Wireless LAN adapter PCB          Controller PCB</p>	<p><b>Detective details:</b>          After receiving a signal from the wireless LAN adapter, the same a signal has not been received for 15sec.</p> 
--	---

<p><b>Forecast of Cause:</b></p> <ol style="list-style-type: none"> <li>1. Connection between A/C and Wireless LAN adapter failure</li> <li>2. Wireless LAN adapter PCB failure</li> <li>3. Controller PCB failure</li> </ol>
---

<p><b>Check Point 1 : Check the connection</b></p> <ul style="list-style-type: none"> <li>• Check any loose or removed connection of between the Wireless LAN adapter PCB and Controller PCB              &gt;If there is abnormal condition, correct it.</li> </ul> <p>Check the connection condition on the Controller PCB              &gt;If there is loose connector, open cable or miswiring, correct it.</p>
---



<p><b>Check Point 2 : Replace wireless LAN adapter</b></p> <ul style="list-style-type: none"> <li>● If Check Point 1 do not improve the symptom, replace Wireless LAN adapter and Please cancel the air conditioner of the registration on the Mobile App.              After the replace adapter, Please perform the pairing on the app.</li> </ul> <p>&gt;&gt;Air conditioning de-registration method, refer to page "02 -36"              &gt;&gt;Pairing method, refer to page "02 - 37"</p>
--



<p><b>Check Point 3 : Replace Controller PCB</b></p> <ul style="list-style-type: none"> <li>● <u>If Check Point 2 do not improve the symptom, replace controller PCB.</u></li> </ul>
--

<p><b>Trouble shooting 27</b>  <b>INDOOR UNIT Error Method:</b>          Wireless LAN adapter Error</p>	<p><b>Indicate of Display:</b>  <b>Indoor Unit :</b>          Operation indicator: No indication          Timer indicator : No indication          Economy indicator: Continuous Flash          Error code :</p> <p><b>Wireless LAN adapter :</b>          LED 1 (Green) : Flashing Fast          LED 2 (Orange) : Flashing Fast</p>
---	--

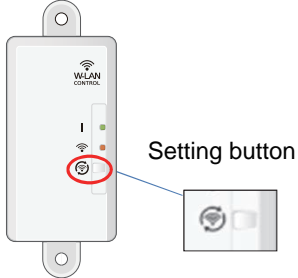
<p><b>Detective Actuators:</b>          Wireless LAN adapter setting button          Wireless LAN adapter PCB</p>	<p><b>Detective details:</b>          When the Setting button becomes ON for consecutive 60 or more seconds.</p> <div data-bbox="1166 465 1465 741" style="text-align: right;">  <p>Setting button</p> </div>
---	--

<p><b>Forecast of Cause:</b></p> <ol style="list-style-type: none"> <li>1. Wireless LAN adapter setting button failure</li> <li>2. Wireless LAN adapter PCB failure</li> </ol>
--

<p><b>Check Point 1 : Check the setting button</b></p> <ul style="list-style-type: none"> <li>• Check if Setting button is kept pressed.             <ul style="list-style-type: none"> <li>&gt; If the Settings button is held down by the foreign matter,  <u>Please remove the foreign matter or remove the cause of the button press.</u></li> </ul> </li> </ul>
--



<p><b>Check Point 2 : Replace wireless LAN adapter</b></p> <ul style="list-style-type: none"> <li>▶ If Check Point 1 do not improve the symptom, replace Wireless LAN adapter and <u>Please cancel the air conditioner of the registration on the Mobile App.</u>  <u>After the replace adapter, Please perform the pairing on the app.</u></li> </ul> <p>&gt;&gt;Air conditioning de-registration method, refer to page "02 -36 "</p> <p>&gt;&gt;Pairing method, refer to page "02 - 37 "</p>
--

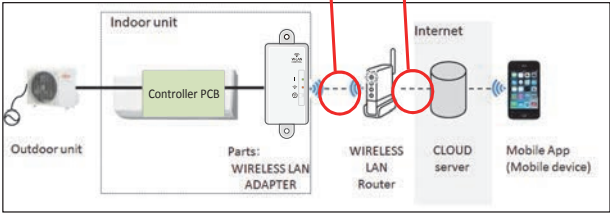

<p><b>Trouble shooting 28</b>  <b>INDOOR UNIT Error Method:</b>          Network Communication Error          (Communication Error of between Wireless LAN Router to Wireless LAN adapter)</p>	<p><b>Indicate of Display:</b>  <b>Indoor Unit :</b>  <b>Operation indicator: No indication</b>  <b>Timer indicator : No indication</b>  <b>Economy indicator: Continuous Flash</b>  <b>Error code :</b></p> <p><b>Wireless LAN adapter :</b>  <b>LED 1 (Green) : ON</b>  <b>LED 2 (Orange) : Flashing Fast</b></p>
--	---

<p><b>Detective Actuators:</b>          Wireless LAN router          Wireless LAN adapter PCB</p>	<p><b>Detective details:</b>          When the Not connection between Wireless LAN adapter and Wireless LAN router.</p> 
---	--

<p><b>Forecast of Cause:</b></p> <ol style="list-style-type: none"> <li>1. Connection cable failure of Wireless LAN router</li> <li>2. Network Connection between Wireless LAN adapter and Wireless LAN router failure</li> <li>3. Wireless LAN router failure</li> <li>4. Wireless LAN adapter PCB failure</li> </ol>
--

<p><b>Check Point 1-1 :</b> Check the position of wireless LAN router</p> <p>Please make sure that the wireless LAN router locates to the place in the limitation for the wireless communication, If the distance between the LAN adapter and the router was out of specification, change the position of the router.</p>	<p><b>Check Point 1-2 :</b> Check the connection cable</p> <ul style="list-style-type: none"> <li>• Check the connection cable on the Wireless LAN router.</li> <li>&gt;If there is loose connector, open cable or miswiring, correct it.</li> </ul>
---	--

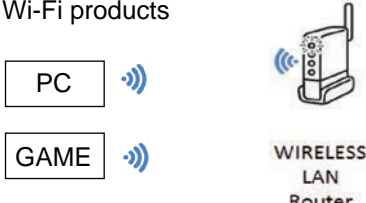
<p><b>Check Point 2-1 :</b> Check the connection status</p> <ul style="list-style-type: none"> <li>• Check the connection status to the Internet and Wireless LAN router.</li> <li>&gt;If the Wireless LAN Router is not connected to the Internet, <u>Please check the transmission between "Wi-Fi products of other than Air conditioner" and "Wireless LAN router".</u></li> </ul>	<p>Ex. ) Wi-Fi products</p> 
---	---

<p><b>OK</b></p>	<p><b>Check Point 2-2 :</b> Check the transmission state</p> <ul style="list-style-type: none"> <li>• Check the Wireless transmission state of Wireless LAN router.(LED status)</li> <li>&gt;If the wireless transmission from the Wireless LAN router has not been outgoing, <u>Please the inquiry to "Wireless LAN router maker".</u></li> </ul>
------------------	--

<p><b>Check Point 3 :</b> Turn on power again of Air conditioner</p> <p>▶ If Check Point 1,2 do not improve the symptom, turn on power again of the Air conditioner, please wait 60 seconds.</p>
--

<p><b>Check Point 4 :</b> Replace Wireless LAN adapter</p> <p>▶ If Check Point 3 do not improve the symptom, replace Wireless LAN adapter and <u>Please cancel the air conditioner of the registration on the Mobile App.</u>  <u>After the replace adapter, Please perform the pairing on the app.</u></p> <p>&gt;&gt;Air conditioning de-registration method, refer to page "02 -36"          &gt;&gt;Pairing method, refer to page "02 - 37"</p>
---

<p><b>Trouble shooting 29</b>  <b>INDOOR UNIT Error Method:</b>  Communication Error  ("Trou.26" and "Trou.28" are simultaneous Error)</p>	<p><b>Indicate of Display:</b>  <b>Indoor Unit :</b>  <b>Operation Indicator : 1 time Flash</b>  <b>Timer indicator : 8 time Flash</b>  <b>Economy indicator: Continuous Flash</b>  <b>Error code: [ E: 18 ]</b></p> <p><b>Wireless LAN adapter :</b>  <b>LED 1 (Green) : Flashing Fast</b>  <b>LED 2 (Orange) : Flashing Fast</b></p>
--	--

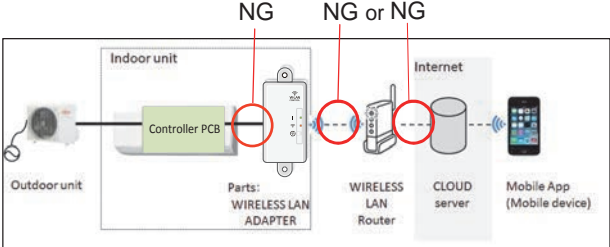
<p><b>Detective Actuators:</b>  Wireless LAN router  Wireless LAN adapter PCB  Indoor unit Controller PCB</p>	<p><b>Detective details:</b>  When the "External Communication Error" and "Network Communication Error" has occurred at the same time.</p> 
---	---

<p><b>Forecast of Cause:</b></p> <ol style="list-style-type: none"> <li>1. Connection cable failure of Wireless LAN router,</li> <li>2. Wireless LAN router failure</li> <li>3. Connection between A/C and Wireless LAN adapter failure</li> <li>4. Network connection between Wireless LAN adapter and Wireless LAN router failure</li> <li>5. Wireless LAN adapter PCB failure,</li> <li>6. Controller PCB failure</li> </ol>
---

**Check Point 1-1 :** Check the position of wireless LAN router

Please make sure that the wireless LAN router locates to the place in the limitation for the wireless communication, If the distance between the LAN adapter and the router was out of specification, change the position of the router.

**Check Point 1-2 :** Check the connection cable

- Check the connection cable on the Wireless LAN router.
- >If there is loose connector, open cable or miswiring, correct it.

OK

OK

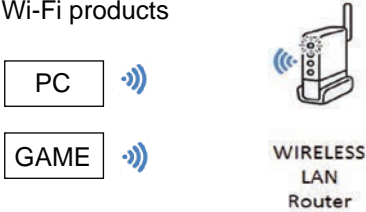
<p><b>Check Point 2 :</b> Check the connection status and transmission state</p>	
<ul style="list-style-type: none"> <li>• Check the connection status to the Internet and Wireless LAN router.</li> <li>&gt;If the Wireless LAN Router is not connected to the Internet,  <u>Please check the transmission between "Wi-Fi products of other than Air conditioner" and "Wireless LAN ruter".</u></li> <li>&gt; When there is no problem with Wi-Fi products &gt;&gt; <u>Refer to "Check Point 4".</u></li> </ul>	<p>Ex. ) Wi-Fi products</p> 
<ul style="list-style-type: none"> <li>• Check the Wireless transmission state of Wireless LAN router.(LED status)</li> <li>&gt;If the wireless transmission from the Wireless LAN Router has not been outgoing,  <u>Please the inquiry to "Wireless LAN router maker".</u></li> </ul> <p>Did the display pattern will change?</p> <div style="border: 1px solid black; padding: 5px; width: fit-content;"> Wireless LAN adapter : LED 1 (Green) : Flashing Fast , LED 2 (Orange) :ON </div>	

YES

NO

**Check Point 3-1 :** Turn on power again of Air conditioner

- If Check Point 1,2 do not improve the symptom,  
turn on power again of the Air conditioner,please wait 60 seconds.
- > When the flashing pattern of the LED 2(Orange) is "ON" >> Refer to "Check Point 3-2".
- > When the flashing pattern of the LED 2(Orange) is "Flashing Fast" >> Refer to "Check Point 4".

To NEXT PAGE

CONTINUATION

YES

Check Point 3-2 : Check the connection

- Check any loose or removed connection of between the Wireless LAN adapter PCB and Controller PCB  
>If there is abnormal condition, correct it.
- Check the connection condition on the Controller PCB  
>If there is loose connector, open cable or miswiring, correct it.

OK

Check Point 4 : Replace Wireless LAN adapter

- ▶ If Check Point 2,3 do not improve the symptom, replace Wireless LAN adapter and Please cancel the air conditioner of the registration on the Mobile App.  
After the replace adapter, Please perform the pairing on the app.  
>>Air conditioning de-registration method, refer to page "02 -36 "  
>>Pairing method, refer to page "02 - 37"

OK

Check Point 5 : Replace Controller PCB

- ▶ If Check Point 4 do not improve the symptom, replace controller PCB.

<p><b>Trouble shooting 30</b>  <b><u>INDOOR UNIT Error Method:</u></b>          Wireless LAN adapter Non-Energized</p>	<p><b><u>Indicate of Display:</u></b>  <b>Indoor Unit :</b>  <b>Operation indicator: 1 time Flash</b>  <b>Timer indicator : 8 time Flash</b>  <b>Economy indicator: Continuous Flash</b>  <b>Error code : [ E : 18 ]</b></p> <p><b>Wireless LAN adapter :</b>  <b>LED 1 (Green) : OFF</b>  <b>LED 2 (Orange) : OFF</b></p>
--	--

<p><b><u>Detective Actuators:</u></b>          Indoor unit Controller PCB          Wireless LAN adapter PCB</p>	<p><b><u>Detective details:</u></b>          When the does not output the DC12 voltage from Controller PCB.</p>
---	---

<p><b><u>Forecast of Cause:</u></b></p> <ol style="list-style-type: none"> <li>1. Indoor unit Controller PCB failure</li> <li>2. Wireless LAN adapter PCB failure</li> <li>3. Wiring connection failure</li> </ol>
--

<p><b>Check Point 1 : Check the Sleep mode</b></p> <ul style="list-style-type: none"> <li>• Press the Wireless LAN adapter setting button the 3 seconds or more.</li> </ul> <p>Did the display pattern will change?</p> <div style="border: 1px solid black; padding: 2px; width: fit-content; margin: 0 auto;">             Wireless LAN adapter : LED 1 (Green) : Flashing Fast , LED 2 (Orange) : Flashing Fast         </div>
---

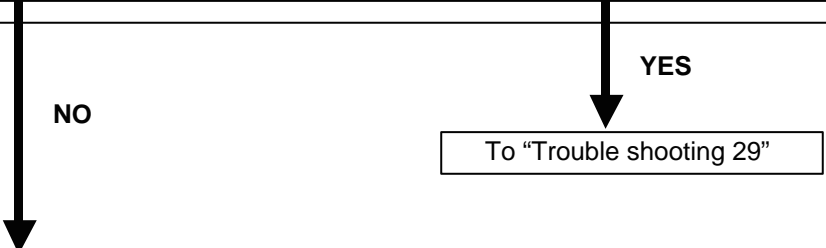

<p><b>Check Point 2 : Check the connection</b></p> <ul style="list-style-type: none"> <li>• Check any loose or removed connection of between the Wireless LAN adapter PCB and Controller PCB              &gt;<u>If there is abnormal condition, correct it.</u></li> <li>Check the connection condition on the Controller PCB              &gt;<u>If there is loose connector, open cable or miswiring, correct it.</u></li> </ul>
---



<p><b>Check Point 3 : Check the Wireless LAN adapter PCB and Controller PCB</b></p> <ul style="list-style-type: none"> <li>• Check Voltage at CN12 (terminal 1-2) of Controller PCB.              &gt;<u>If it is DC 0V, Controller PCB is failure.</u>              ► <u>Replace Controller PCB.</u></li> <li>&gt;<u>If it is DC12V, Wireless LAN adapter PCB failure.</u>              ► <u>Replace Wireless LAN adapter and please cancel the air conditioner of the registration on the Mobile App.</u>  <u>After the replace adapter, Please perform the pairing on the App.</u></li> <li>&gt;&gt;Air conditioning unregistration method, refer to page "02 - 36 "</li> <li>&gt;&gt;Pairing method, refer to page "02 - 37"</li> </ul>	<div style="border: 1px solid black; padding: 5px; display: inline-block;"> <b>DC</b>   </div>
---	---

<b>Trouble shooting 31</b> <b>INDOOR UNIT Error Method:</b> Wireless LAN adapter Sleep mode	<b>Indicate of Display:</b> Indoor Unit : Operation lamp: No indication Timer lamp : No indication ERROR CODE : [ No indication ] <table border="0" style="float: right; margin-left: 20px;"> <tr> <td>Wireless LAN adapter :</td> <td></td> </tr> <tr> <td>LED 1 (Green) :</td> <td>OFF</td> </tr> <tr> <td>LED 2 (Orange) :</td> <td>OFF</td> </tr> </table>	Wireless LAN adapter :		LED 1 (Green) :	OFF	LED 2 (Orange) :	OFF
Wireless LAN adapter :							
LED 1 (Green) :	OFF						
LED 2 (Orange) :	OFF						

<b>Detective Actuators:</b> Sleep mode	<b>Detective details:</b> When the state in which fly a wireless(SSID) have passed 1 hour.
---	---

<b>Forecast of Cause:</b> 1. Sleep mode
--

<b>Check Point 1 : Check the sleep mode</b>
<ul style="list-style-type: none"> <li>· Press the Wireless LAN adapter setting button the 3 seconds or more.</li> </ul> Did the display pattern will change? <div style="border: 1px solid black; padding: 2px; width: fit-content;">           Wireless LAN adapter : LED 1 (Green) : ON , LED 2 (Orange) : Flashing Fast         </div>

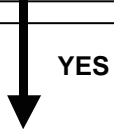

To "Trouble shooting 28"

## Air Conditioning De-registration Method

If you replace the Wireless LAN adapter, you will need to de-register all of the conditioner information on the App. Unregister method is as follows.

- 1 Launch the mobile app(FGL air).



- 2 Please long-push the registered "Device name" of Air Conditioner.



- 3 Then will display the "Unregister" button. Please tap the "Unregister" button.

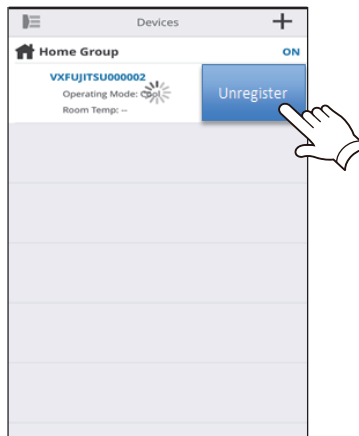

- 4 Please tap the "Yes" .

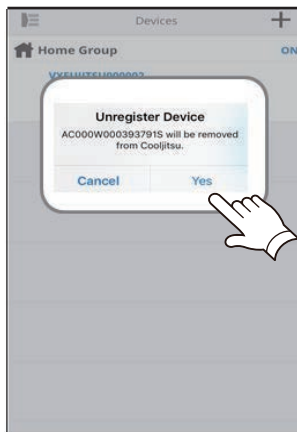

- 5 Air Conditioner Unregister is complete.

# Air conditioner registration Pairing Method

Choose from the following modes to connect your Air conditioner to your Wireless LAN router.

- Note:**
- Before starting this setting, wait for **60 seconds** or more after the power supply is connected to the air conditioner (via breaker or plug).
  - If both LED 1 and 2 are off, the WLAN adapter may be in Sleep mode. Be sure it is deactivated before setting up the wireless LAN. (Refer to "SETTING MANUAL")
  - Check that the smartphone or tablet PC is linked to the wireless router you are connecting the air conditioner. The setting will not work if it is not connected to the same wireless router.
  - The display screen design may differ depending on the version of the mobile app.
  - To control 2 or more air conditioners with the same smartphone or tablet PC, repeat the setup of the chosen mode.

## Button Mode

\*Lighting pattern: ○ OFF ● ON ● Flashing

1 Launch the mobile app(FGL air).



2 Sign in with your Email address and password (as registered in "4.2. User registration") following the screen on the mobile app.

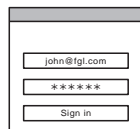

3 Press the [+] button to add a new air conditioner.



4 Confirm that LED 2 is flashing.(On/off at 2-second intervals.) Then select [Button mode] on the screen.  
If LED 1 and 2 are off, push the Setting button once.  
(Refer to "5. SLEEP MODE" SETTING MANUAL)

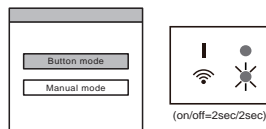

5 Press the WPS button on the wireless router that you are connecting to.  
Refer to the operating manual of the wireless router for the location of the button and how to press it.



6 Confirm that LED 2 is flashing.  
(On/off at 2-second intervals.)  
Then press and hold the Setting button on the WLAN adapter for 3 seconds.

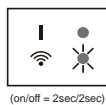

LED 2 lighting will change.  
(on/off: 2sec/2sec → 2sec/0.5sec)

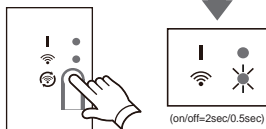

Confirm that the LED 1 and 2 is both on to proceed.



7 Press [Register] to start the connection with the wireless router.

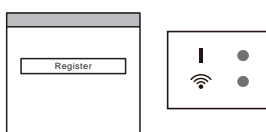

LED 1 and 2 will both flash 2 times, and a message will appear when setup is complete.

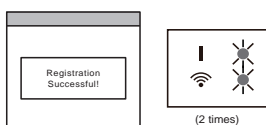

## Manual mode

\*Lighting pattern: ○ OFF ● ON ● Flashing

1~3 See steps 1 to 3 in "4.3.1. Button mode"

4 Select [Manual mode].

If LED 1 and 2 are off, push the Setting button once. (Refer to "5. SLEEP MODE" SETTING MANUAL)

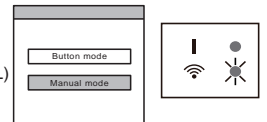

**[For Android]**

5 Select the SSID of the air conditioner you are connecting to.

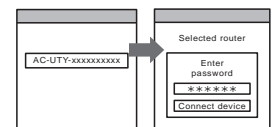

6 Input the PIN code written on the WLAN label.

7 Select the SSID of the wireless router you are connecting to.  
Input the wireless router (WLAN access point) password then press [Connect device].

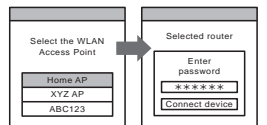

8 LED 1 and 2 will both flash 2 times, and a message will appear when setup is complete.

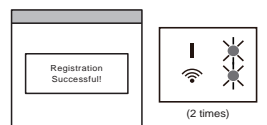

**[For iOS]**

5 Select [Open W-LAN setting] or activate the wireless LAN by pressing the Home button -> [Setting] -> [Wi-fi].  
Select the SSID of the air conditioner you are connecting to.

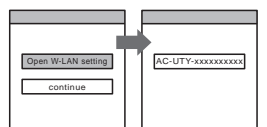

6 Input the PIN code written on the WLAN label.

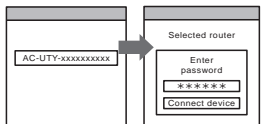

7 Select the SSID of the wireless router you are connecting to.  
Input the wireless router (WLAN Access Point) password then press [Connect device].

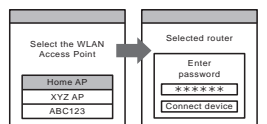

LED 1 and 2 will both flash 2 times, and a message will appear when setup is complete.

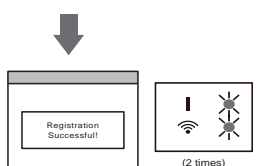

## 2-6 TROUBLE SHOOTING WITH NO ERROR CODE

### Trouble shooting 32

Indoor Unit - No Power

#### Forecast of Cause:

1. Power Supply failure
2. External cause
3. Electrical Components defective

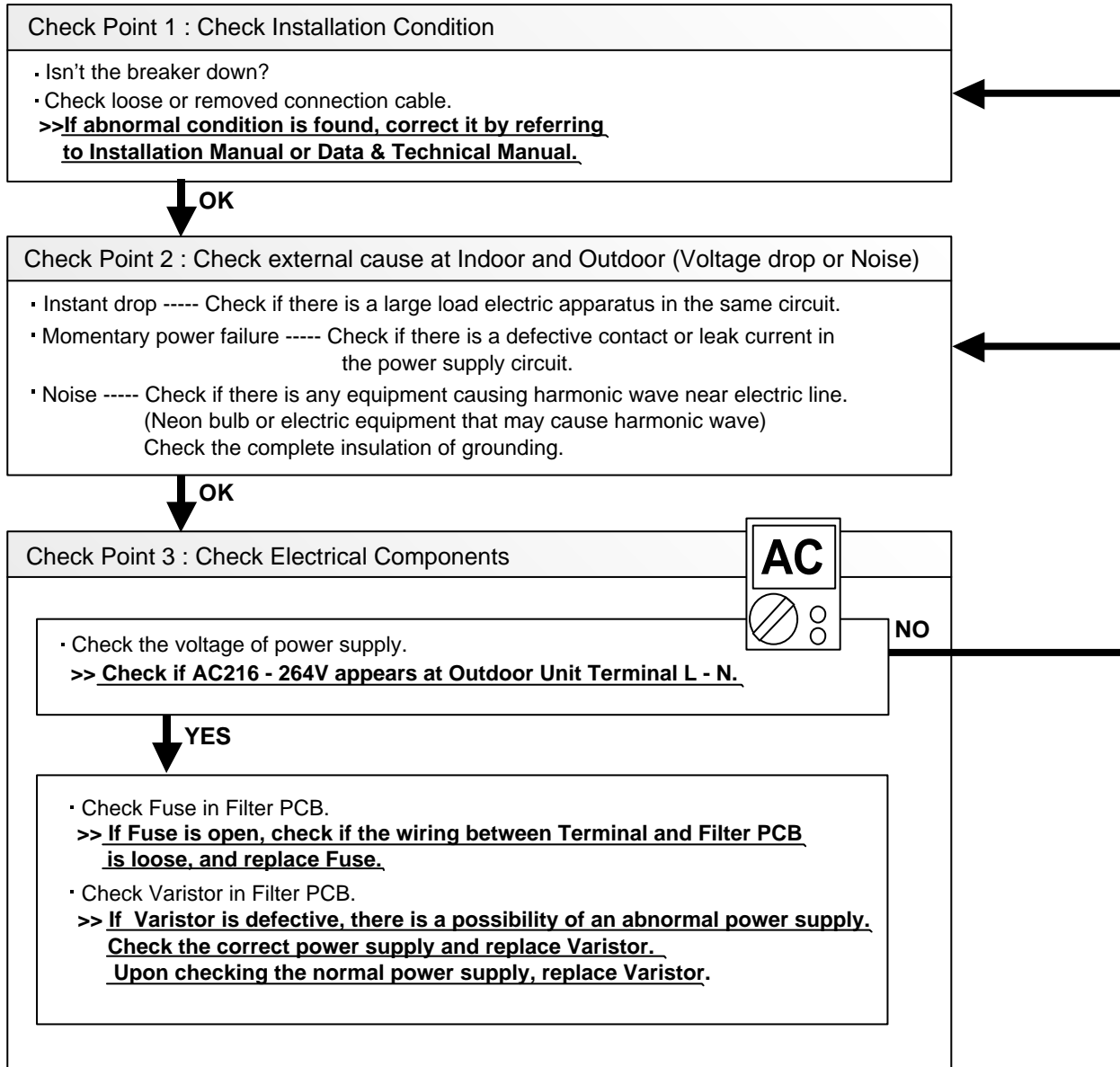



**Trouble shooting 33**

Outdoor Unit - No Power

Forecast of Cause:

1. Power Supply failure
2. External cause
3. Electrical Components defective

**Check Point 1 : Check Installation Condition**

- Isn't the breaker down?
- Check loose or removed connection cable.
- >>If abnormal condition is found, correct it by referring to Installation Manual or Data & Technical Manual.**

**OK**

**Check Point 2 : Check external cause at Indoor and Outdoor (Voltage drop or Noise)**

- Instant drop ----- Check if there is a large load electric apparatus in the same circuit.
- Momentary power failure ----- Check if there is a defective contact or leak current in the power supply circuit.
- Noise ----- Check if there is any equipment causing harmonic wave near electric line.  
(Neon bulb or electric equipment that may cause harmonic wave)  
Check the complete insulation of grounding.

**OK**

**Check Point 3 : Check Electrical Components**

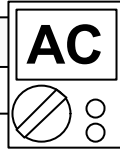

**NO**

- Check the voltage of power supply.
- >> Check if AC216 - 264V appears at Outdoor Unit Terminal L - N.**

**YES**

- Check Fuse in Main PCB.
- >> If Fuse is open, check if the wiring between Terminal and Main PCB is loose, and replace Fuse.**

**OK**

**► If the symptom does not change by above Check 3, replace Main PCB.**

### Trouble shooting 34

No Operation (Power is ON)

### Forecast of Cause:

1. Setting/ Connection failure
2. External cause
3. Electrical Component defective

#### Check Point 1 : Check indoor and outdoor installation condition

- Indoor Unit - Check incorrect wiring between Indoor Unit - Remote Control.  
Or, check if there is an open cable connection.
- Are these Indoor Unit, Outdoor Unit, and Remote Control suitable model numbers to connect?  
**>> If there is some abnormal condition, correct it by referring to Installation manual and Data & Technical Manual.**

↓  
**OK**

Turn off Power and check/ correct followings.

- Is there loose or removed communication line of Indoor Unit and Outdoor Unit?

↓  
**OK**

#### Check Point 2 : Check external cause at Indoor and Outdoor (Voltage drop or Noise)

- Instant drop ----- Check if there is a large load electric apparatus in the same circuit.
- Momentary power failure ----- Check if there is a defective contact or leak current in the power supply circuit.
- Noise ----- Check if there is any equipment causing harmonic wave near electric line.  
(Neon bulb or electric equipment that may cause harmonic wave)  
Check the complete insulation of grounding.

## Trouble shooting 35

No Cooling / No Heating

### Forecast of Cause:

1. Indoor Unit error
2. Outdoor Unit error
3. Effect by Surrounding environment
4. Connection Pipe / Connection Wire failure
5. Refrigeration cycle failure

#### Check Point 1 : Check Indoor Unit

- Does Indoor unit FAN run on HIGH FAN?
- Is Air Filter dirty?
- Is Heat Exchanger clogged?
- Check if Energy save function is operated.



#### Check Point 2 : Check Outdoor Unit Operation

- Check if Outdoor Unit is operating
- Check any objects that obstruct the air flow route.
- Check clogged Heat Exchanger.
- Is the Valve open?



#### Check Point 3 : Check Site Condition

- Is capacity of Indoor unit fitted to Room size?
- Any windows open? Or direct sunlight ?



#### Check Point 4 : Check Indoor/ Outdoor Installation Condition

- Check connection pipe (specified pipe length & Pipe diameter?)
- Check any loose or removed communication line.
- >> **If there is an abnormal condition, correct it by referring to Installation Manual or Data & Technical Manual.**



#### Check Point 5 : Check Refrigeration cycle

- Check if Strainer is clogged (Refer to the figure at right).
- Measure Gas Pressure and if there is a leakage, correct it.
- >> **When recharging the refrigerant, make sure to perform vacuuming, and recharge the specified amount.**
- Check EEV (PARTS INFORMATION 3)
- Check Compressor (PARTS INFORMATION 1,2)

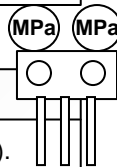

#### Attention

Strainer normally does not have temperature difference between inlet and outlet as shown in ①, but if there is a difference like shown in ②, there is a possibility of inside clogged. In this case, replace Strainer.

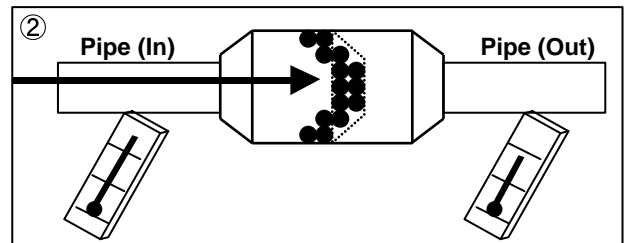
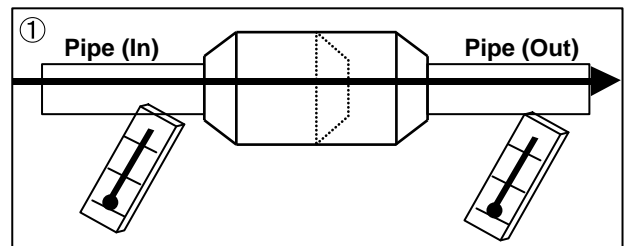

### Trouble shooting 36

#### Abnormal Noise

#### Forecast of Cause :

1. Abnormal installation (Indoor/ Outdoor)
2. Fan failure (Indoor/ Outdoor)
3. Compressor failure (Outdoor)

#### Diagnosis method when Abnormal Noise is occurred

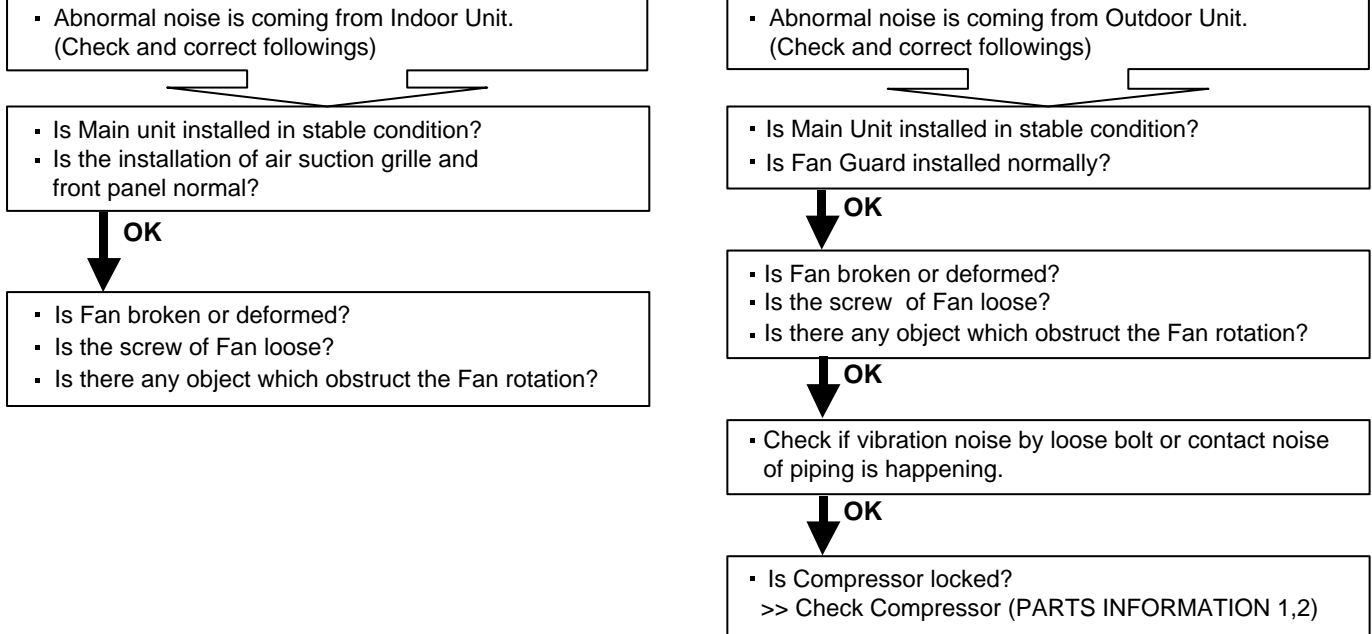

### Trouble shooting 37

#### Water Leaking

#### Forecast of Cause:

1. Erroneous installation
2. Drain hose failure

#### Diagnosis method when water leak occurs

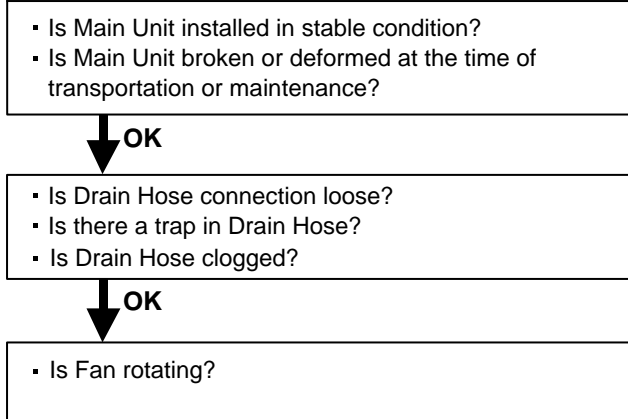

#### Diagnosis method when water is spitting out.

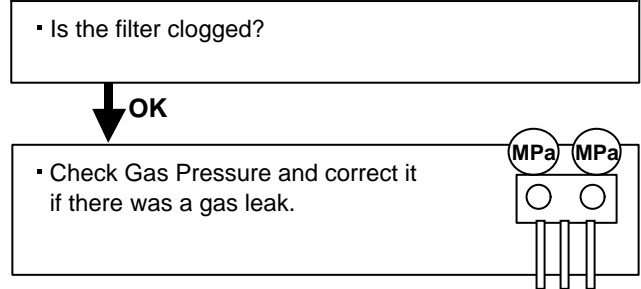

## 2-7 SERVICE PARTS INFORMATION

### SERVICE PARTS INFORMATION 1

#### Compressor

Diagnosis method of Compressor ( If Outdoor Unit LED displays Error, refer to Trouble shooting )

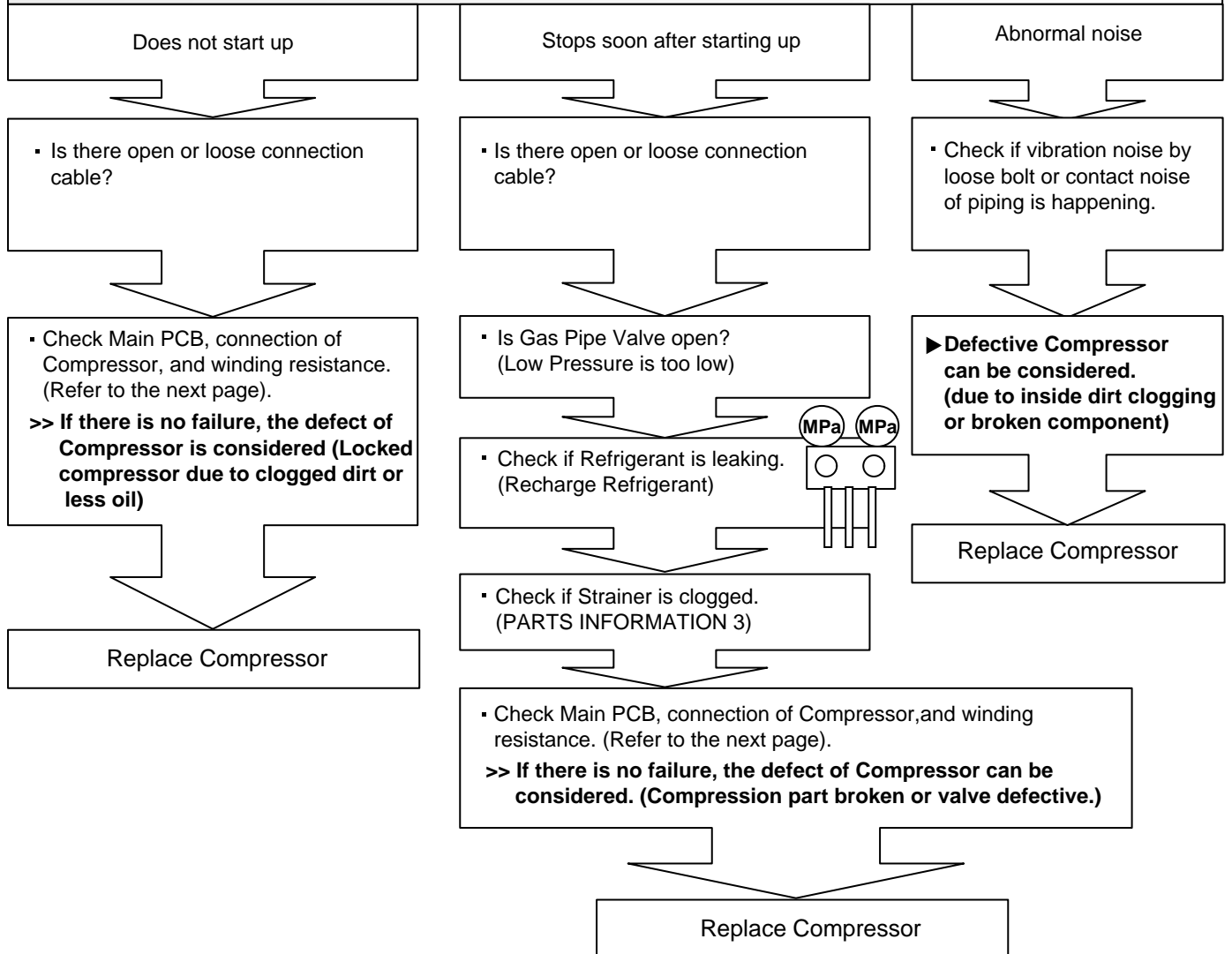

## SERVICE PARTS INFORMATION 2

### Inverter Compressor

#### Check Point 1 : Check connection

- Check terminal connection of Compressor (Loose or incorrect wiring)

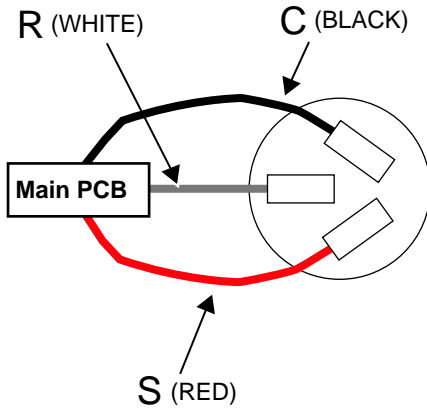

- Check connection of compressor terminals (Loose or incorrect wiring)

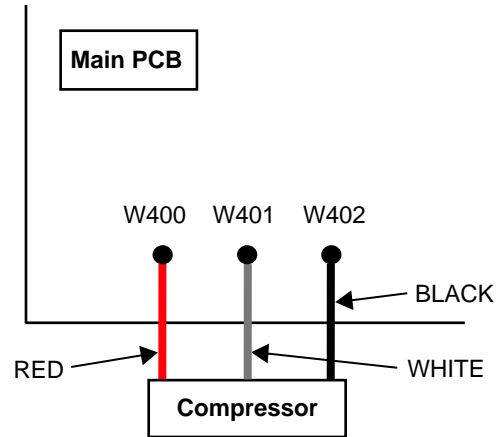

#### Check Point 2 : Check winding resistance

- Check winding resistance of each terminal  
▶ **If the resistance value is 0  $\Omega$  or infinite, replace Compressor.**

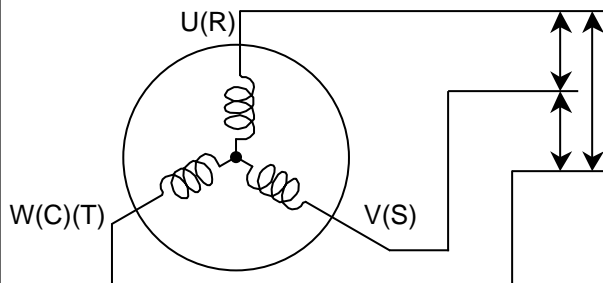

Resistance Value :  
1.740  $\Omega$  at 20°C

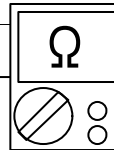

#### Check Point 3 : Replace Inverter PCB

- ▶ **If Check Point 1, 2 do not improve the symptom, replace Main PCB.**

### SERVICE PARTS INFORMATION 3

#### Outdoor unit Electronic Expansion Valve (EEV)

##### Check Point 1 : Check Connections

- Check connection of connector ( Loose connector or open cable )

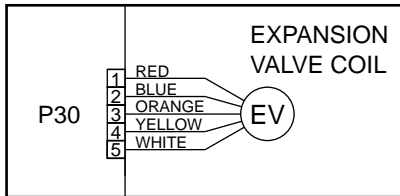

##### Check Point 2 : Check Coil of EEV

- Remove connector, check each winding resistance of Coil.

Read wire	Resistance value
White - Red	$46 \Omega \pm 4 \Omega$ at 20°C
Yellow - Red	
Orange - Red	
Blue - Red	

► **If Resistance value is abnormal, replace EEV.**

##### Check Point 3 : Check Voltage from Main PCB.

- Remove Connector and check Voltage (DC12V)

► **If it does not appear, replace Main PCB.**



##### Check Point 4 : Check Noise at start up

- Turn on Power and check operation noise.

► **If an abnormal noise does not show, replace Main PCB.**

##### Check Point 5 : Check Opening and Closing Operation of Valve

When Valve is closed, it has a temp. difference between Inlet and Outlet.

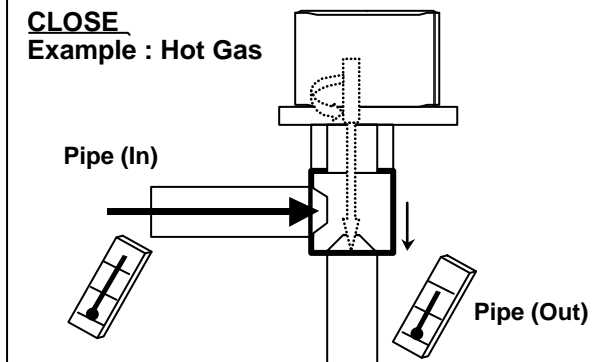

If it is open, it has no temp. difference between Inlet and Outlet.

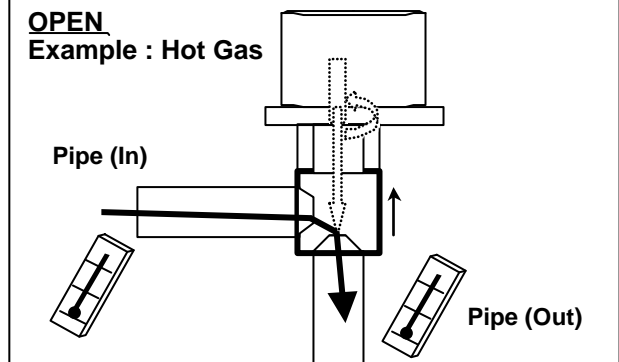

##### Check Point 6 : Check Strainer

Strainer normally does not have temperature difference between inlet and outlet as shown in ①, but if there is a difference as shown in ②, there is a possibility of inside clogged. In this case, replace Strainer.

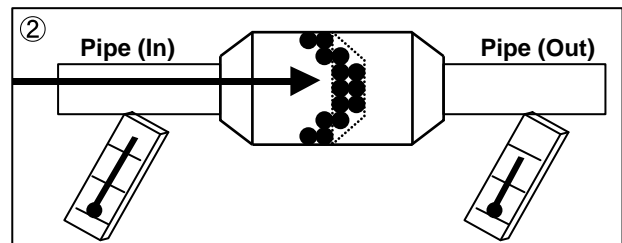
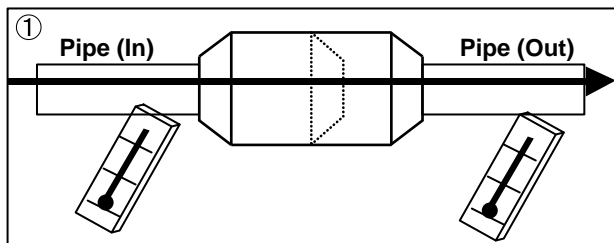

#### **SERVICE PARTS INFORMATION 4**

Indoor unit fan motor

##### Check Point 1 : Check rotation of Fan

- Rotate the fan by hand when operation is off.  
(Check if fan is caught, dropped off or locked motor)
- >>If Fan or Bearing is abnormal, replace it.**

##### Check Point 2 : Check resistance of Indoor Fan Motor

- Refer to below. Circuit-test "Vm" and "GND" terminal.  
(Vm: DC voltage, GND: Earth terminal)
- >>If they are short-circuited (below 300 k $\Omega$ ), replace Indoor fan motor and Controller PCB.**

Pin number (wire color)	Terminal function (symbol)
1 (Red)	DC voltage (Vm)
2	No function
3	No function
4 (Black)	Earth terminal (GND)
5 (White)	Control voltage (Vcc)
6 (Yellow)	Speed command (Vsp)
7 (Blue)	Feed back (FG)

#### **SERVICE PARTS INFORMATION 5**

Outdoor unit fan motor

##### Check Point 1 : Check rotation of Fan

- Rotate the fan by hand when operation is off.  
(Check if fan is caught, dropped off or locked motor)
- >>If Fan or Bearing is abnormal, replace it.**

##### Check Point 2 : Check resistance of Outdoor Fan Motor

- Refer to below. Circuit-test "Vm" and "GND" terminal.  
(Vm: DC voltage, GND: Earth terminal)
- >>If they are short-circuited (below 300 k $\Omega$ ), replace Outdoor fan motor and Main PCB.**

Pin number (wire color)	Terminal function (symbol)
1 (Red)	DC voltage (Vm)
2	No function
3	No function
4 (Black)	Earth terminal (GND)
5 (White)	Control voltage (Vcc)
6 (Yellow)	Speed command (Vsp)
7 (Brown)	Feed back (FG)



## SERVICE PARTS INFORMATION 6

### Main PCB (IPM Check)

#### Check Point 1



① Disconnect the connection wires between the Main PCB - Compressor.

② Set the tester to the "Resistance" mode, and measure the resistance between the following terminals.

TM301 (P) - W400(S) / W401(R) / W402(C)

TM302 (N) - W400(S) / W401(R) / W402(C)

\*Make sure that the compressor wires are not short-circuit during the measuring.

③ Judge the result of ② as follows:

Terminal		Resistance value
Tester(+)	Tester(-)	
P	W400	Over 2k $\Omega$ (Including $\infty\Omega$ )
P	W401	
P	W402	
W400	P	Over 20k $\Omega$ (Including $\infty\Omega$ )
W401	P	
W402	P	
N	W400	
N	W401	
N	W402	
W400	N	Over 2k $\Omega$ (Including $\infty\Omega$ )
W401	N	
W402	N	

#### Check Point 2



④ Set the tester to the "Diode" mode, and measure the voltage value between the following terminals.

\*Make sure that the compressor wires are not short-circuit during the measuring.

⑤ Judge the result of ④ as follows:

Terminal		Tester display
Tester(+)	Tester(-)	
P	W400	$\infty$
P	W401	
P	W402	
W400	P	0.3V ~ 0.7V
W401	P	
W402	P	
N	W400	
N	W401	
N	W402	
W400	N	$\infty$
W401	N	
W402	N	

# ***WALL MOUNTED type INVERTER***

## **3 . APPENDING DATA**

### 3. FUNCTION SETTING

To adjust the functions of this product according to the installation environment, various types of function settings are available.

**NOTE:** Incorrect settings can cause a product malfunction.

## 3-1 Function settings by using remote controller

Some function settings can be changed on the remote controller. After confirming the setting procedure and the content of each function setting, select appropriate functions for your installation environment.

### Setting procedure by using wireless remote controller

The function number and the associated setting value are displayed on the LCD of the remote controller. Follow the instructions written in the local setup procedure supplied with the remote controller, and select appropriate setting according to the installation environment.

**Before connecting the power supply of the indoor unit, reconfirm following items:**

- Cover for the electrical enclosure on the outdoor unit is in place.
- There is no wiring mistake.
- Piping air tight test and vacuuming have been performed firmly.
- All the necessary wiring work for outdoor unit has been finished.

After reconfirming the items listed above, connect the power supply of the indoor unit.

**NOTE:** Settings will not be changed if invalid numbers or setting values are selected.

#### Entering function setting mode:

While pressing the POWERFUL button and TEMP. (∧) button simultaneously, press the RESET button to enter the function setting mode.

#### Selecting the function number and setting value:

1. Press the TEMP. (∧) (∨) buttons to select the function number. To switch between the left and right digits, press the 10 °C HEAT button.
2. Press the POWERFUL button to proceed to value setting. To return the function number selection, press the POWERFUL button again.
3. Press the TEMP. (∧) (∨) buttons to select the setting value. To switch between the left and right digits, press the 10 °C HEAT button.
4. Press the MODE button once to send the function setting information. Confirm that you hear the beep sound.
5. Press the START/STOP button to fix the function setting. Confirm that you hear the beep sound.
6. Press the RESET button to end the function setting mode.
7. After completing the function setting, be sure to disconnect the power supply and then reconnect it.



### **⚠ CAUTION**

After disconnecting the power supply, wait 30 seconds or more before reconnecting it. The function setting will not become active unless the power supply is disconnected and then reconnected.

# Contents of function setting

Each function setting listed in this section is adjustable in accordance with the installation environment.

**NOTE:** Setting will not be changed if invalid numbers or setting values are selected.

## ● Function setting list

	Function no.	Functions
1)	10	Filter clean operation interval
2)	24	Left/right swing operation range
3)	30/31	Room temperature control for indoor unit sensor
4)	40	Auto restart
5)	44	Remote controller custom code
6)	49	Indoor unit fan control for energy saving for cooling
7)	92	Dual fan airflow (in COOL, DRY, and FAN modes)
8)	93	Dual fan vertical airflow angle (in COOL, DRY, and FAN modes)
9)	97	Maintenance indicator switchover

### 1) Filter clean operation interval

Select appropriate intervals for automatically cleaning the air filter according to environmental conditions and the conditions of use.

Function number	Setting value	Setting description	Factory setting
10	00	Standard (Approximately once every 5 days)	◆
	01	Long interval (Approximately once every 8 days)	
	02	Short interval (Approximately once every 3 days)	
	03	Disable	

### 2) Left/right swing operation range

Select the operation range of the left/right swing according to the installation condition.

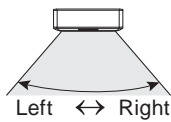
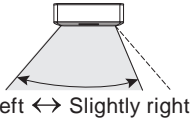
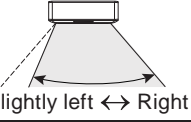
Function number	Setting value	Setting description		Factory setting
24	00	Standard		◆
	01	Left side		
	02	Right side		

### 3) Room temperature control for indoor unit sensor

Depending on the installed environment, correction of the room temperature sensor may be required. Select the appropriate control setting according to the installed environment.

The temperature correction values show the difference from the Standard setting "00" (manufacturer's recommended value).

Function number		Setting value	Setting description	Factory setting	
30 (For cooling)	31 (For heating)	00	Standard setting	◆	
		01	No correction 0.0 °C		
		02	-0.5 °C	More cooling Less heating	
		03	-1.0 °C		
		04	-1.5 °C		
		05	-2.0 °C		
		06	-2.5 °C		
		07	-3.0 °C		
		08	-3.5 °C		
		09	-4.0 °C		
		10	+0.5 °C	Less cooling More heating	
		11	+1.0 °C		
		12	+1.5 °C		
		13	+2.0 °C		
		14	+2.5 °C		
		15	+3.0 °C		
		16	+3.5 °C		
17	+4.0 °C				

### 4) Auto restart

Enables or disables automatic restart after a power interruption.

Function number	Setting value	Setting description	Factory setting
40	00	Enable	◆
	01	Disable	

**NOTE:** Auto restart is an emergency function such as for power outage etc. Do not attempt to use this function in normal operation. Be sure to operate the unit by remote controller or external device.

### 5) Remote controller custom code

(Only for wireless remote controller)

The indoor unit custom code can be changed. Select the appropriate custom code.

Function number	Setting value	Setting description	Factory setting
44	00	A	◆
	01	B	
	02	C	
	03	D	

## 6) Indoor unit fan control for energy saving for cooling

Enables or disables the power-saving function by controlling the indoor unit fan rotation when the outdoor unit is stopped during cooling operation.

Function number	Setting value	Setting description	Factory setting
49	00	Disable	
	01	Enable	
	02	Remote controller	◆

00: When the outdoor unit is stopped, the indoor unit fan operates continuously following the setting on the remote controller.

01: When the outdoor unit is stopped, the indoor unit fan operates intermittently at a very low speed.

02: Enable or disable this function by remote controller setting.

### NOTES:

- As the factory setting, this setting is initially activated.
- Set to "00" or "01" when connecting a remote controller that cannot set the Fan control for energy saving function or connecting a network converter.  
To confirm if the remote controller has this setting, refer to the operating manual of each remote controller.

## 7) Dual fan airflow (in COOL, DRY, and FAN modes)

Switches the dual fan vertical airflow in COOL, DRY, and FAN modes. (Set this when the dual fan airflow is too strong or week.)

Function number	Setting value	Setting description	Factory setting
92	00	Standard	◆
	01	Down	
	02	Up	

## 8) Dual fan vertical airflow angle (in COOL, DRY, and FAN modes)

Switches the dual fan vertical airflow angle in COOL, DRY, and FAN modes. (Set this when the dual fan airflow hits furniture or does not reach the intended area.)

Function number	Setting value	Setting description	Factory setting
93	00	Standard (70°)	◆
	01	0°	
	02	30°	
	03	40°	
	04	45°	
	05	50°	
	06	60°	

## 9) Maintenance indicator switchover

Display/hide the indicator that shows when to clean the dust box or the plasma air clean unit.

Function number	Setting value	Setting description	Factory setting
97	00	Enable	◆
	01	Disable	

## 3-2 Custom code setting for wireless remote controller

To interconnect the air conditioner and the wireless remote controller, assignment of the custom code for the wireless remote controller is required.

**NOTE:** Air conditioner cannot receive a signal if the air conditioner has not been set for the custom code.

When 2 or more air conditioners are installed in a room, and the remote controller is operating an air conditioner other than the one you wish to set, change the custom code of the remote controller to operate only the air conditioner you wish to set. (4 selections possible.)

Confirm the setting of the remote controller custom code and the function setting. If these do not match, the remote controller cannot be used to operate for the air conditioner.

1. Press the START/STOP button until only the clock is displayed on the remote controller display.
2. Press the MODE button for at least 5 seconds to display the current custom code. (Initially set to  $\text{H}$ .)
3. Press the TEMP. ( $\wedge$ ) ( $\vee$ ) buttons to change the custom code between  $\text{H}$   $\rightarrow$   $\text{b}$   $\rightarrow$   $\text{c}$   $\rightarrow$   $\text{d}$ . Match the code on the display to the air conditioner custom code. (Initially set to  $\text{H}$ .)
4. Press the MODE button again to return to the clock display. The custom code will be changed.



### NOTES:

- If no button is pressed within 30 seconds after the custom code is displayed, the system returns to the original clock indicator. In this case, start again from step 1.
- The air conditioner custom code is set to  $\text{H}$  prior to shipment. To change the custom code, contact your retailer.
- If you do not know the assigned code for the air conditioner, try each of the custom code ( $\text{H}$   $\rightarrow$   $\text{b}$   $\rightarrow$   $\text{c}$   $\rightarrow$   $\text{d}$ ) until you find the code which operates the air conditioner.

---

### 3-3 Switching the temperature unit of remote controller

Displayed temperature unit on the remote controller LCD can be switched between °C (Celsius) and °F (Fahrenheit).

To change temperature unit, do as follows:

1. Press the TEMP. (Up) button (∧) for at least 5 seconds to display the current temperature unit. (Factory setting: °C)
2. Press the TEMP. (∧) (∨) buttons to switch the temperature unit between °C and °F.
3. With either of pressing the START/STOP button or no additional button operation for 30 seconds in step 2., the temperature unit currently selected will be set.

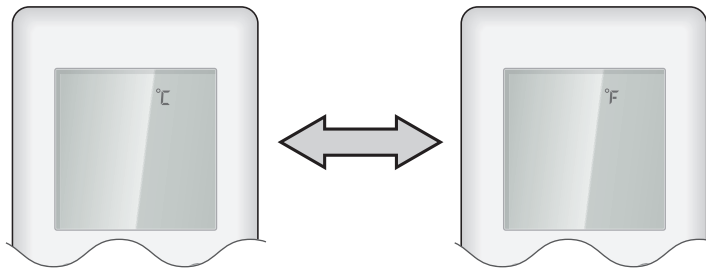



# 4. WIRING DIAGRAMS

## INDOOR UNIT

### Main PC board

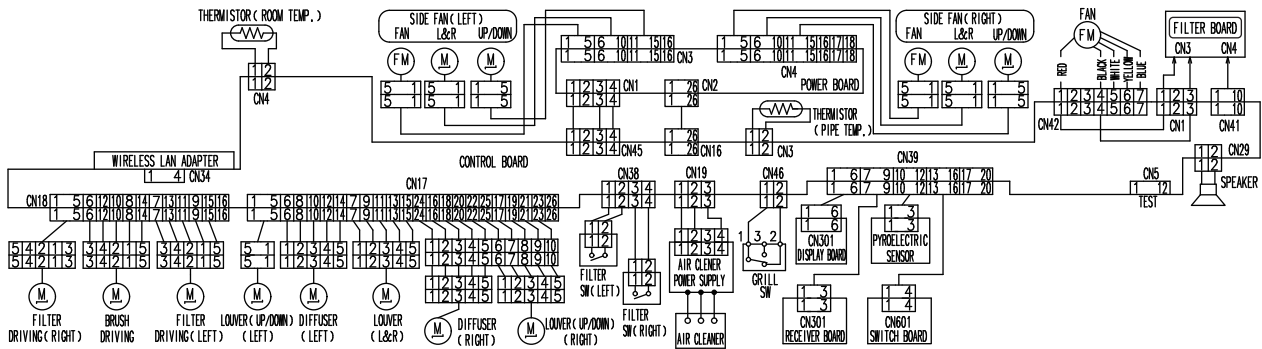

### Sub PC board

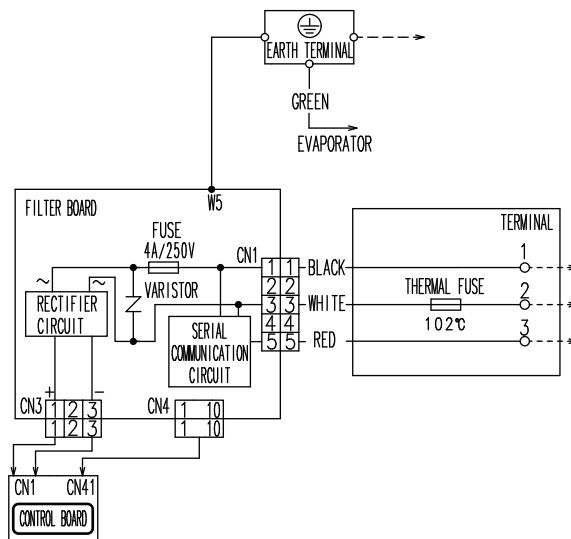

## OUTDOOR UNIT

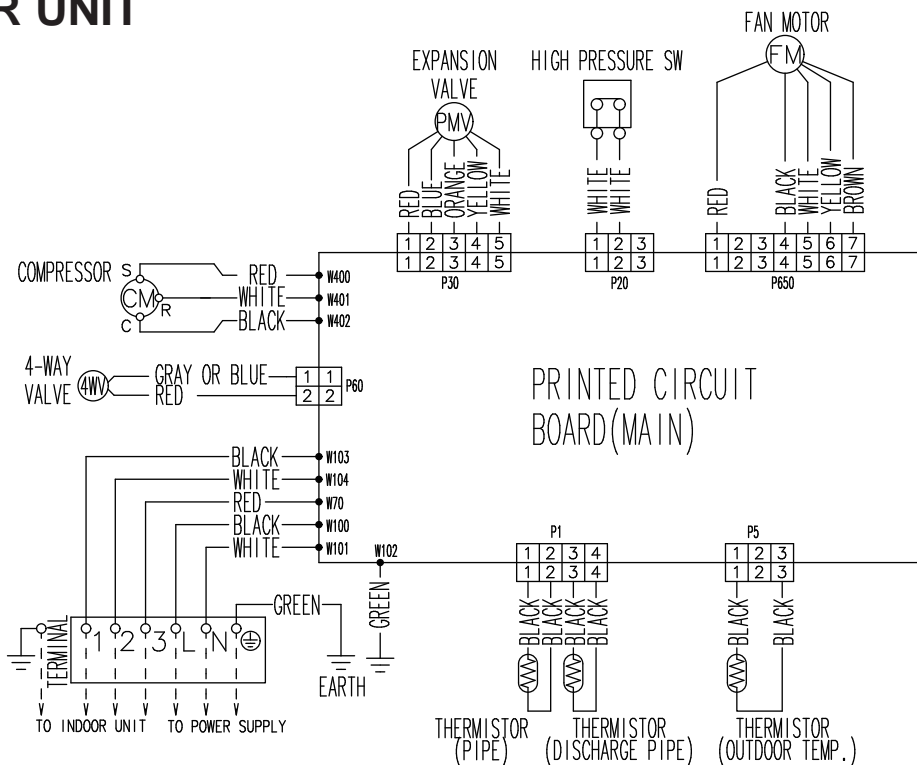

# ***WALL MOUNTED type INVERTER***

## **4. DISASSEMBLY PROCESS**

## 4-1 DISASSEMBLY PROCESS ( INDOOR UNIT )

### ⚠ WARNING

Before servicing the unit, turn off all power supplies.  
Then, do not touch the electric parts for 10 minutes due to the risk of electric shock.

### 1. Air Filter and dust box removal

Start from opening the Intake grille.

1. Slide the stopper to the right.
2. The handles rise up.
3. Up the handle and pull the Air filter and dust box.



### Mounting the Air filter and dust box.

1. Set the lower edge of Air filter with the horizontal ▷◁ marks.
2. Inset the top of Air filter to the rails
3. Inset the Air filter with dust box.

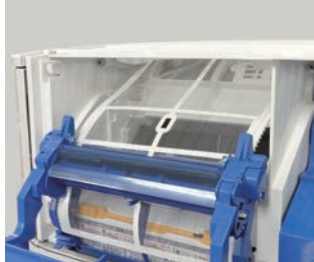

### 2. Plasma air clean unit removal

Start from opening the Intake grille.

1. Pull the handle down toward you and pull out.



### 3. Intake grille removal

Start from opening the Intake grille.



From this state, lift the Intake grille up and remove the Intake grille hooks.

**(Tips!)** When you see this photo, and remove the intake grille toward you.

**⚠ WARNING**

Before servicing the unit, turnings off all power supplies.  
Then, do not touch the electric parts for 10 minutes due to the risk of electric shock.

#### 4. Front panel removal

Start from removing Intake grille.

1. Remove the screws. ( 7 places )

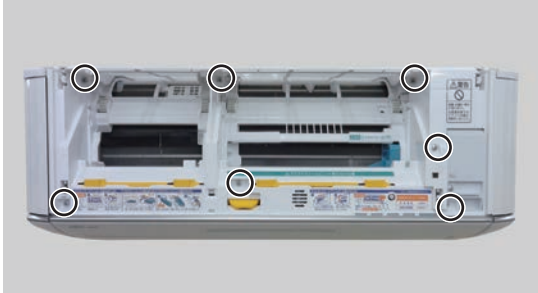

2. Remove the Front panel.

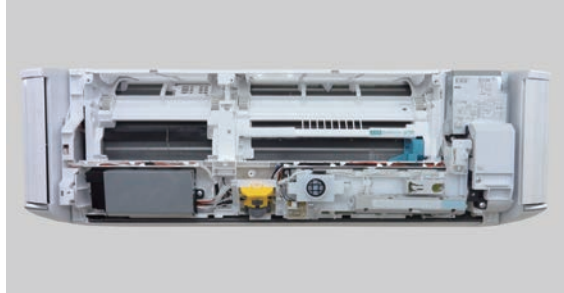

**(Tips!)** When installing the Side fan, attach 1 screw temporarily to prevent fall down.

3. Mounting the screws. ( 2 places )

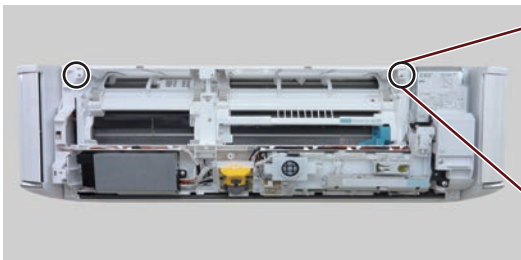

#### 5. Access for PCB cards

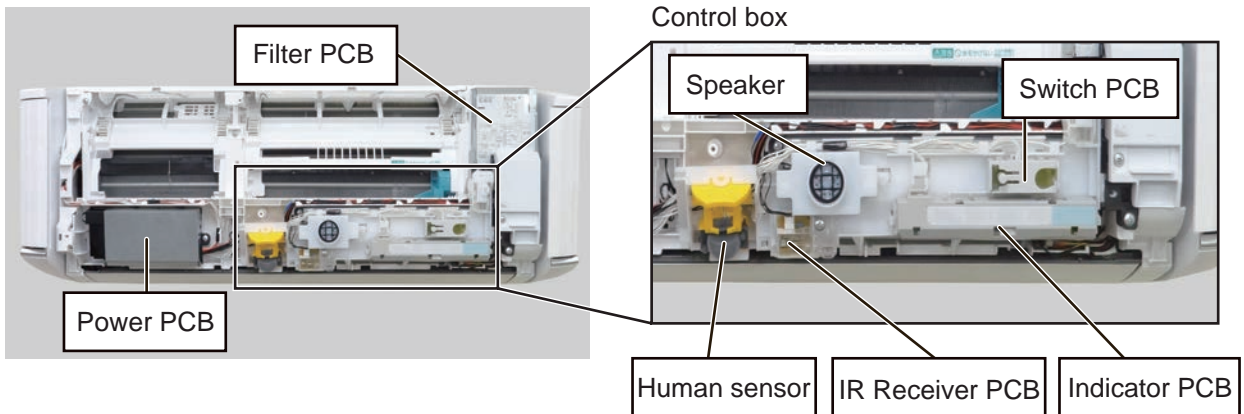

Remove the Control box tab, and open the Control box to the front.

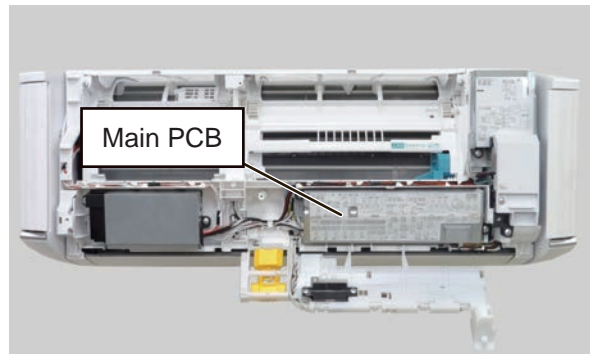
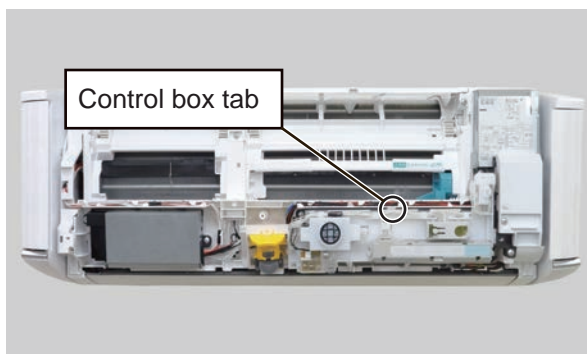

**⚠ WARNING**

Before servicing the unit, turn off all power supplies.  
Then, do not touch the electric parts for 10 minutes due to the risk of electric shock.

### 6. Filter PCB removal

Start from opening the Control box.

1. Remove the screws ( 2 places ) and covers.
2. Remove the earth wire and disconnect the all connector.
3. Push left side supporter and remove the Filter PCB.



### 7. Main PCB removal

Start from opening the Control box.

1. Pull the left edge of the knob, remove the pawl and box cover.
2. Disconnect 15\* connectors (\*When the wireless LAN in use)
3. Push supporters and remove the Main PCB.

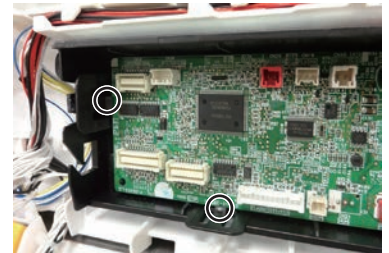

### 8. Power PCB removal

Start from removing the Front panel

1. Remove the screw and cover.
2. Disconnect the all connectors of Power PCB.
3. Push supporter and remove the Power PCB.

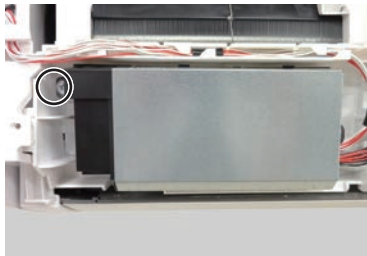

### 9. Indicator PCB removal

Start from removing the Front panel.

1. Push the hooks. ( 2 places )
2. Push the hooks. ( 2 places )
3. Disconnect the connector.

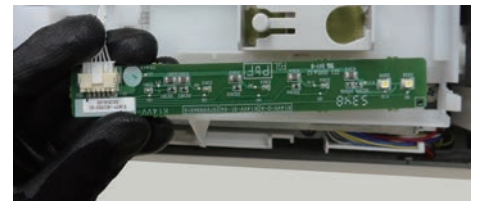
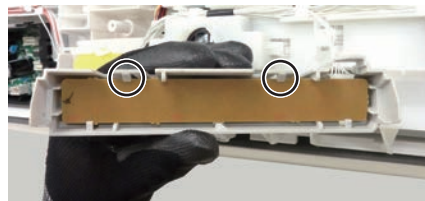

**⚠ WARNING**

Before servicing the unit, turn off all power supplies.  
Then, do not touch the electric parts for 10 minutes due to the risk of electric shock.

### 10. Switch PCB removal

Start from removing the Front panel.

1. Push the hooks. ( 2 places )    2. Push the hook.

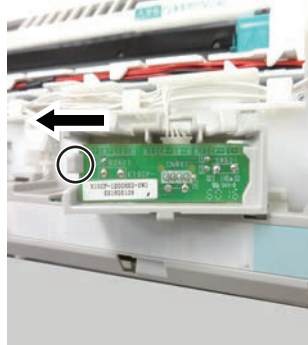
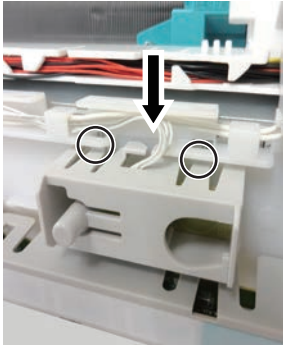

3. Disconnect the connector.

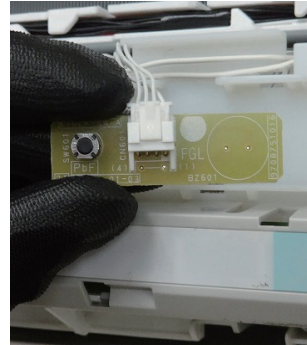

### 11. IR Receiver PCB removal

Start from removing the Front panel.

1. Remove the screw and cover.    2. Push upside supporter.    3. Disconnect the connector.

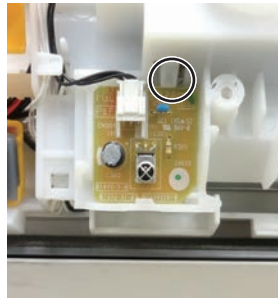
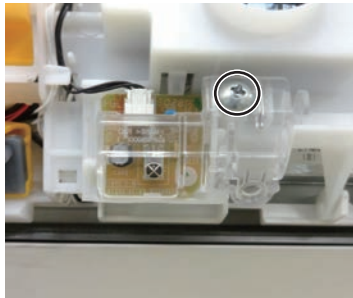

### 12. Speaker removal

Start from removing the Front panel.

1. Disconnect the connector of Main PCB. ( CN29 / Red )    2. Cut binder and remove the screws. ( 2 places )

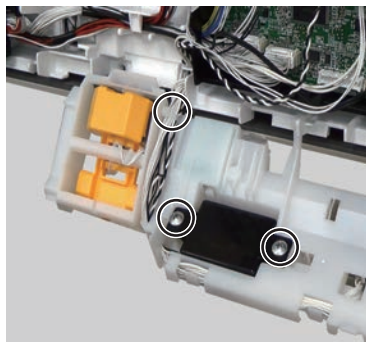
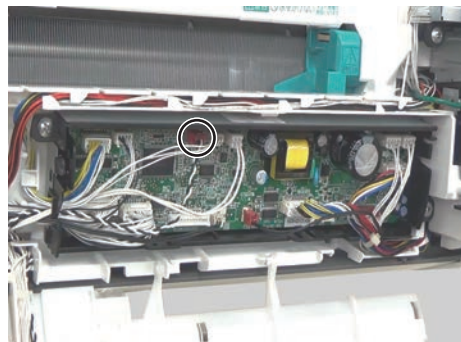

**⚠ WARNING**

Before servicing the unit, turn off all power supplies.  
Then, do not touch the electric parts for 10 minutes due to the risk of electric shock.

### 13. Human Sensor removal

Start from opening Control box.

1. Release cables.

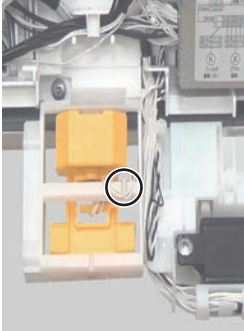

2. Release top shaft and bottom shaft from holder.

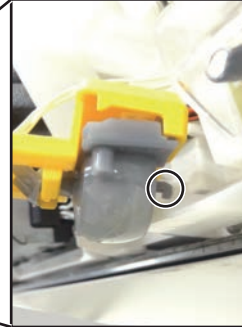
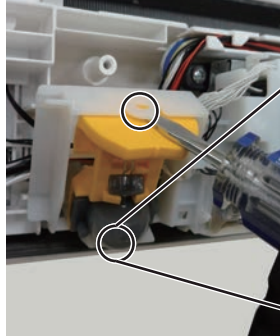

3. Release bottom the hooks. ( 2 places )



4. Disconnect the connector.

### 14. Grill switch removal

Start from removing Main frame.

1. Disconnect the connector of Main PCB. ( CN46 / White )

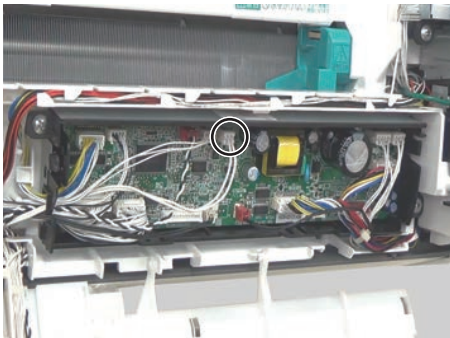

2. Remove the hook.



3. Remove the hooks. ( 2 places )



### 15. Under cover removal



Remove the screw cap and screws. ( 3 places )



There are hooks on both sides. Bend the center and remove each other.

**⚠ WARNING**

Before servicing the unit, turn off all power supplies.  
Then, do not touch the electric parts for 10 minutes due to the risk of electric shock.

## 16. Side fan removal

Start from removing Front panel and Under cover.

### Side fan ( Left ) removal

1. Disconnect the connector of Power PCB. ( CN3 / White )
2. Remove the screw.

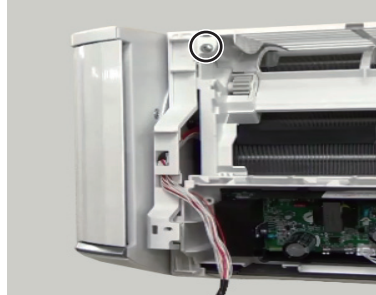

3. Remove the underside hook with your right hand while supporting with the left hand.

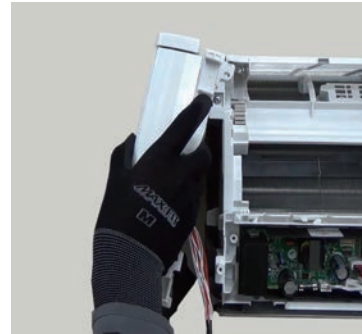
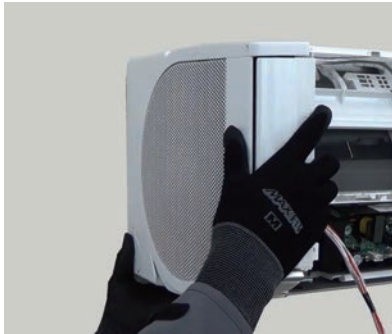

4. Remove the screws ( 5 places ) and step motor.
5. Remove the Side fan panel L.

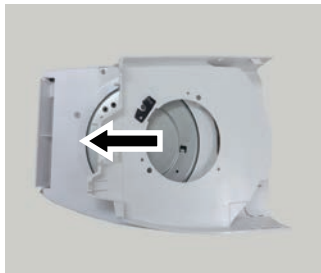
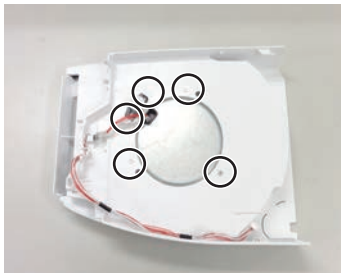

---

### Mounting the Side fan ( Left )

Start from mounting Main frame.

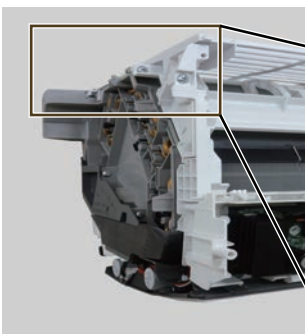

Fit the black circle of the Side fan with the indoor unit.

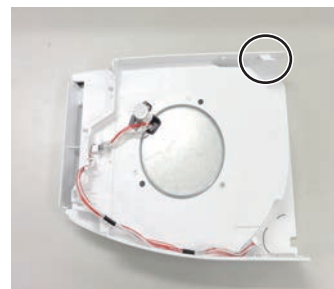
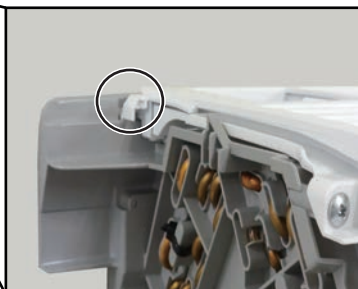

Underside hook is reverse Side fan removing.



**⚠ WARNING**

Before servicing the unit, turn off all power supplies.  
Then, do not touch the electric parts for 10 minutes due to the risk of electric shock.

Start from removing Front panel and Under cover.

**Side fan ( Right ) removal**

1. Disconnect the connector of Power PCB. ( CN4 / White )
2. Disconnect the connector of Filter PCB. ( CN1 / CN41 )
3. Remove the earth wire and screw.

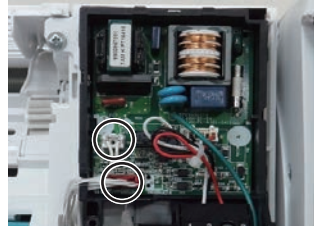

4. Remove the underside hook with your right hand while supporting with the left hand.

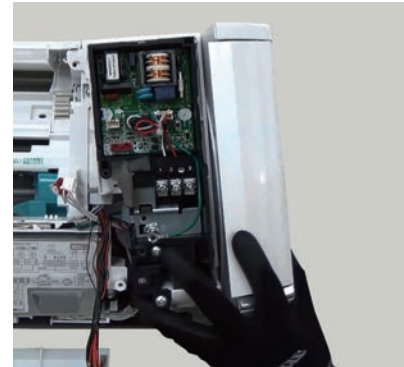

5. Remove the screws ( 5 places ) and step motor.
6. Remove the Side fan panel R.

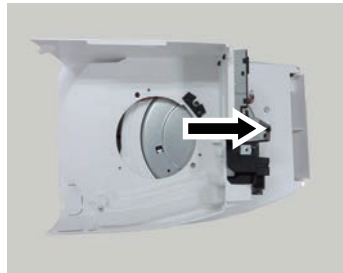
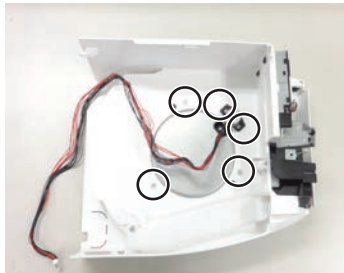

**Mounting the Side fan ( Right )**

Start from mounting Main frame.

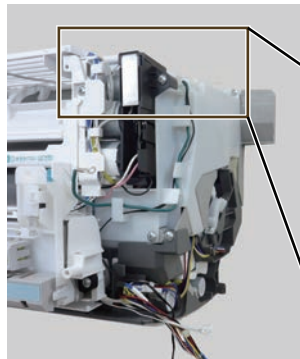

Fit the black circle of the Side fan with the indoor unit.

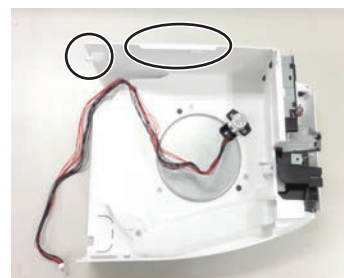

Underside hook is reverse Side fan removing.

**⚠ WARNING**

Before servicing the unit, turnings off all power supplies.  
Then, do not touch the electric parts for 10 minutes due to the risk of electric shock.

## 17. Main frame removal

Start from removing Side fans.

1. Disconnect the connectors of Main PCB. ( CN3 / CN17 / CN42 )

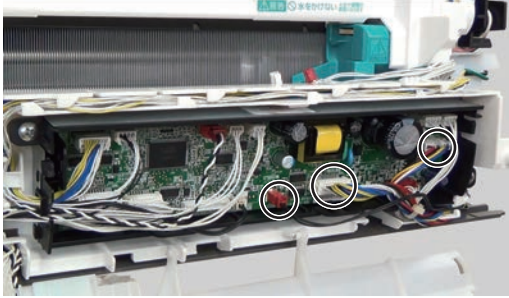

2. Remove the screws. ( 5 places )

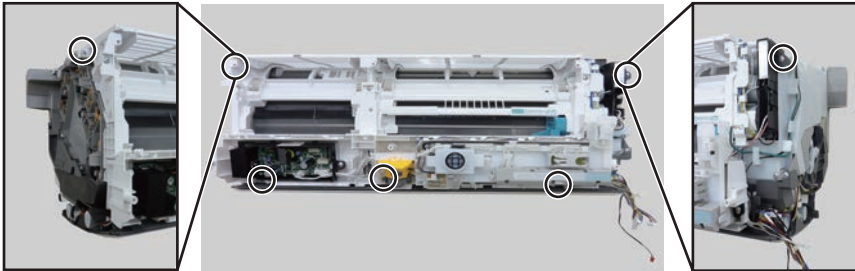

3. Remove the Main frame.

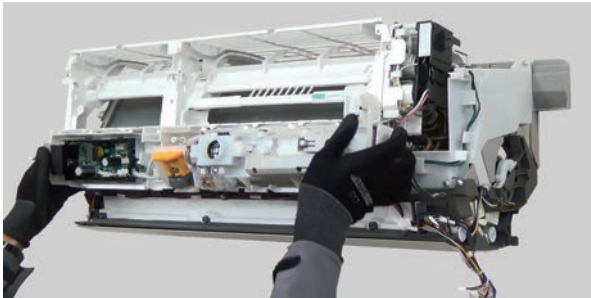

Lift the Main frame upward, and pull toward you.

**(Tips!)** Do not too lift up the under port.

## 18. Limit switch removal

Start from removing main frame.

1. Disconnect the connector of Main PCB. ( CN38 / White )
2. Remove the screws ( 3 places ) and rail cover.
3. Remove the hook.
4. Remove the hooks. ( 3 places )

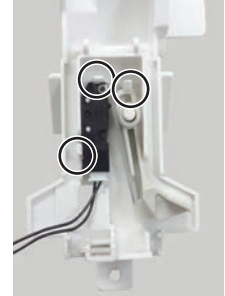
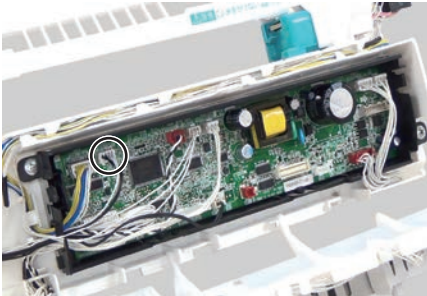

**⚠ WARNING**

Before servicing the unit, turn off all power supplies.  
Then, do not touch the electric parts for 10 minutes due to the risk of electric shock.

## 22. Casing removal

Start from removing Side cover.

1. Remove the screws and pipe stopper. ( 2 places )

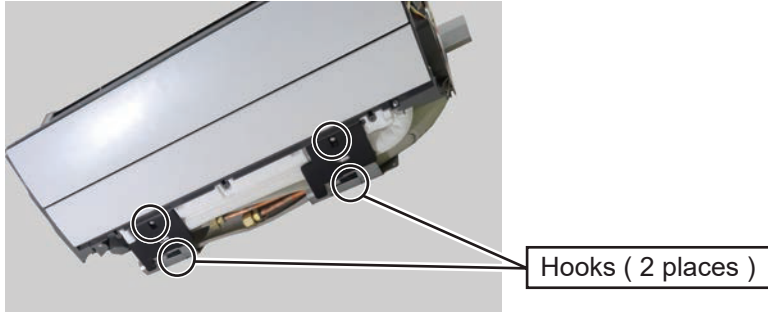

2. Remove the screws. ( 4 places )

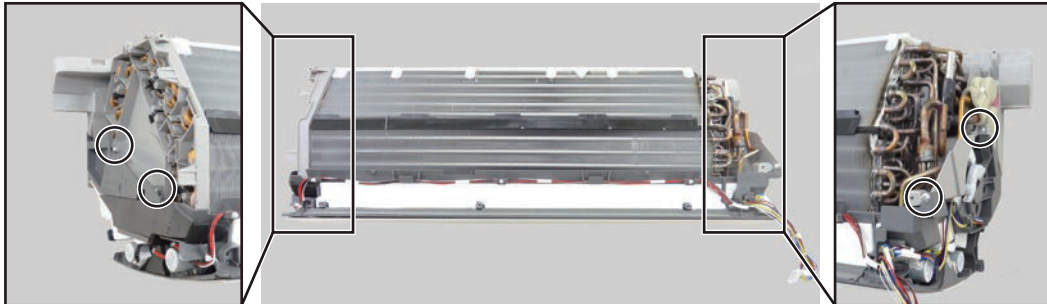

3. Remove the casing.

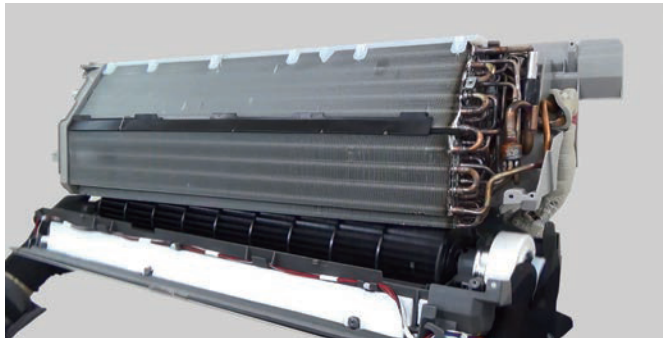

Lift the Casing assy so as not to drop out from the wall bracket, then remove it diagonally downward.

**⚠ WARNING**

Before servicing the unit, turn off all power supplies.  
Then, do not touch the electric parts for 10 minutes due to the risk of electric shock.

### 19. Room temperature thermistor removal

Start from removing rail cover.

1. Disconnect the connector of Main PCB. ( CN4 / White )

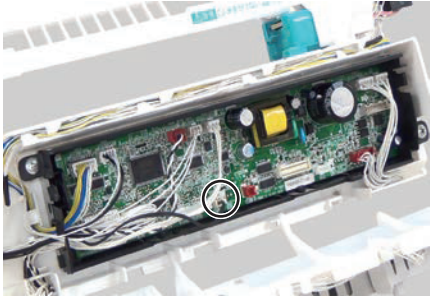

2. Remove the screw and thermistor case.



3. Remove the Room temperature thermistor.



### 20. Plasma unit removal

Start from removing main frame.

1. Disconnect the connector of Main PCB. ( CN19 / White )

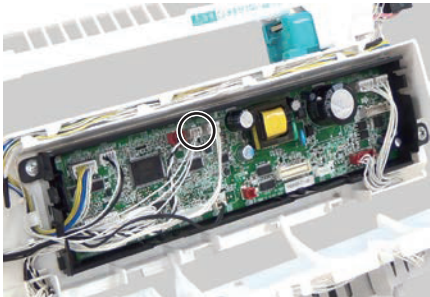

2. Remove the screws. ( 3 places )

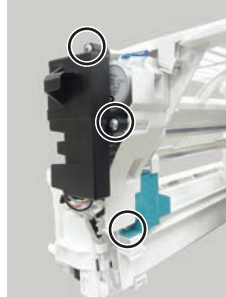

3. Bend the gear unit side panel slightly. Remove the Plasma unit.

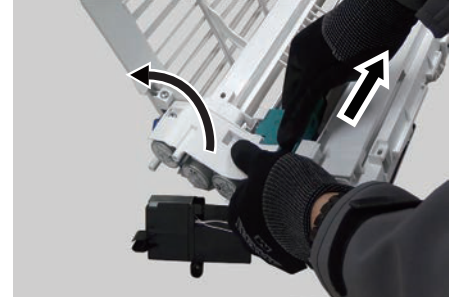

### 21. Pipe temperature thermistor removal

Start from removing main frame.

1. Remove the screws ( 3 places ) and earth wire.

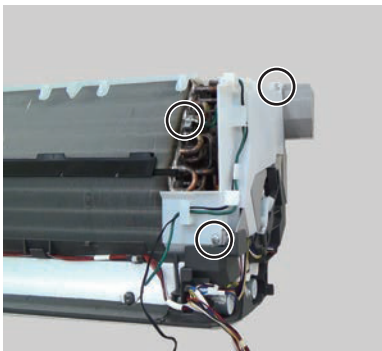

3. Remove the Thermistor spring and Pipe temperature thermistor.

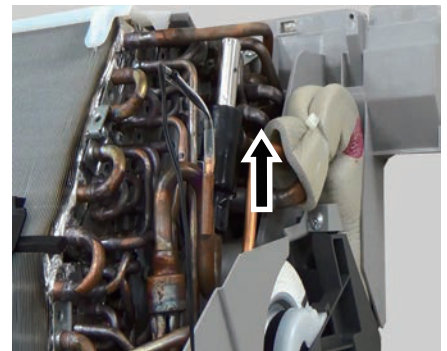

**(Tips)** Pipe temperature thermistor can be removed without removing Side cover.

**⚠ WARNING**

Before servicing the unit, turn off all power supplies.  
Then, do not touch the electric parts for 10 minutes due to the risk of electric shock.

### 23. Fan motor removal

Start from removing Casing.

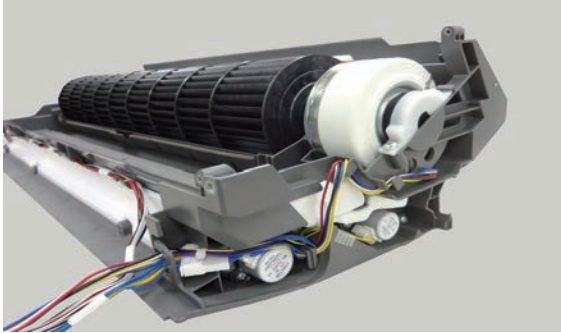

1. Remove the screw and holder.

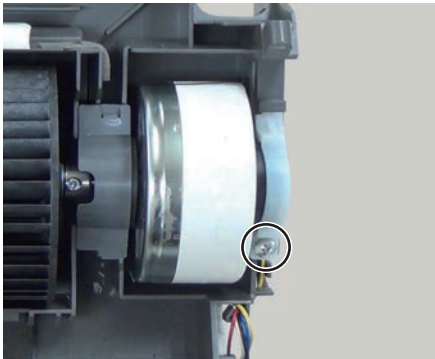

2. Remove the screw.



Lift the Cross flow fan and Fan motor, then remove the Fan motor.

#### Mounting the Fan motor

When installing the Fan motor set the Fan motor and Fan to the designated position

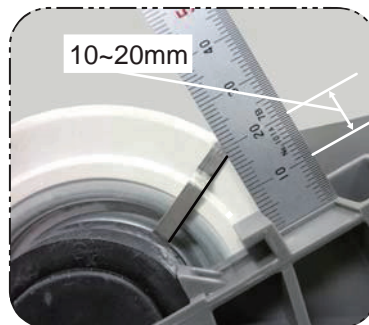
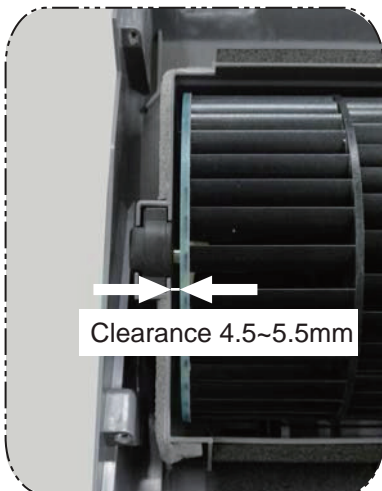

The basis is the underside of the Silver part as shown in photo.

Set the silver part between 10~20mm of the scale as shown in photo.

## 4-2 DISASSEMBLY PROCESS ( OUTDOOR UNIT )

### ⚠ WARNING

Before servicing the unit, turnings of all power supplies.  
Then, do not touch the electric parts for 10 minutes due to the risk of electric shock.

### 1. Top panel removal

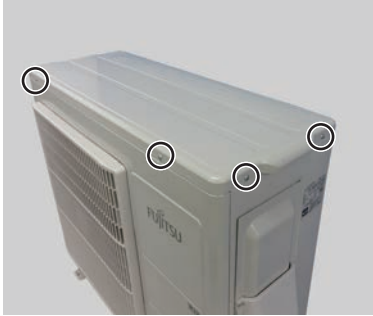

1. Remove the screws ( 6 places ).



Left side view.



2. Remove the Top panel.

### 2. Front panel removal

Start from opening the Top panel.

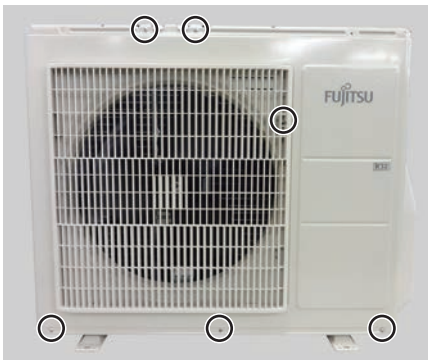

1. Remove the screws ( 6 places ).

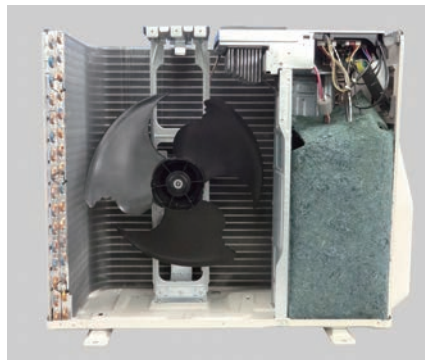

2. Remove the Front panel.

### 3. Valve cover and Switch cover removal

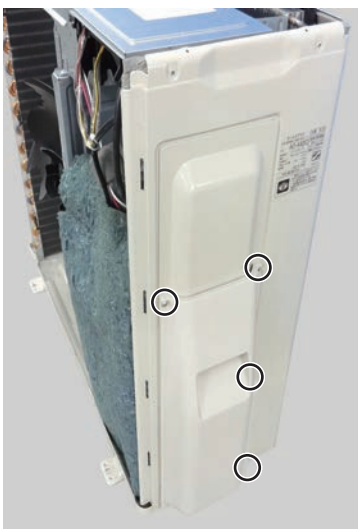

1. Remove the screws ( 4 places ).



2. Remove the Valve cover.



3. Remove the Switch cover.

**⚠ WARNING**

Before servicing the unit, turnings of all power supplies.  
Then, do not touch the electric parts for 10 minutes due to the risk of electric shock.

### 4. Inverter PCB removal

Start from removing Front panel and Valve and switch cover.

1. Remove the screws ( 2 places ).



2. Remove the Hex socket screw.  
Open Compressor terminal cover  
and disconnect 3 wires.

3. Open electric box cover and  
disconnect 6 connectors.  
(P1 / P5 / P20 / P30 / P60 / P650 )

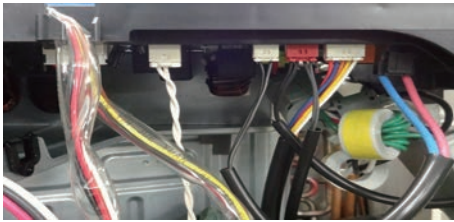

4. Release cables from cable guide and  
remove the screw and remove electric box.



5. Disconnect 5 connectors.



6. Cut binder and remove earth wire.

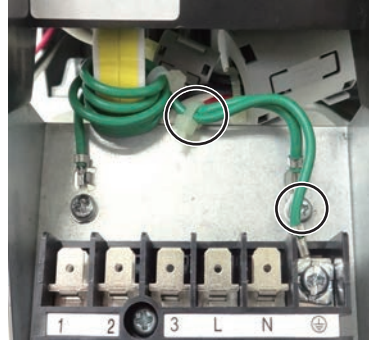

7. Remove the screws ( 7 places ).

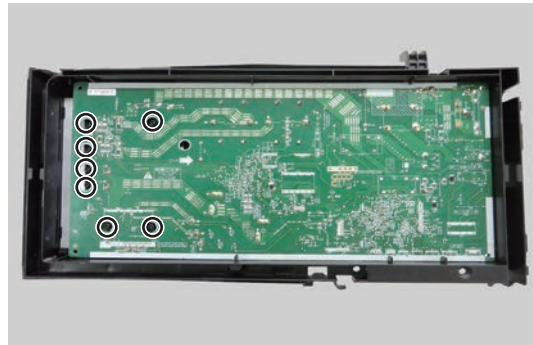

8. Remove the Inverter PCB from case.

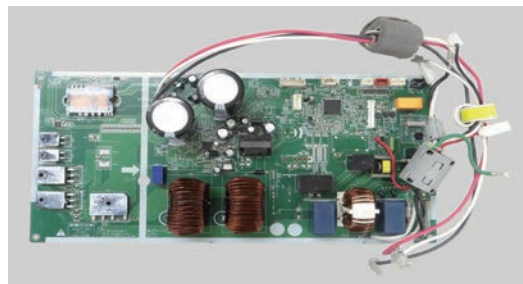

9. Remove the EMI filters. ( 3 places )  
Remove the Core. ( 1 place )

**Tips!**

Before mounting a new PCB, wipe all old thermal  
grease of the heat sink then apply new one.

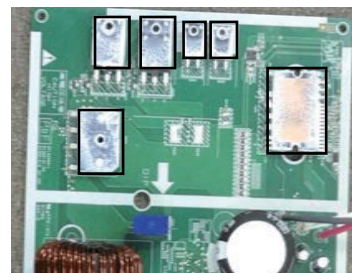

**⚠ WARNING**

Before servicing the unit, turnings of all power supplies.  
Then, do not touch the electric parts for 10 minutes due to the risk of electric shock.

### 5. Fan motor removal

Start from opening the Front panel.

1. Remove the Electric box cover and release cables from cable guide.
2. Disconnect the connector. ( P650 / White )
3. Cut the binder with Fan motor wire and Solenoid coil wire.

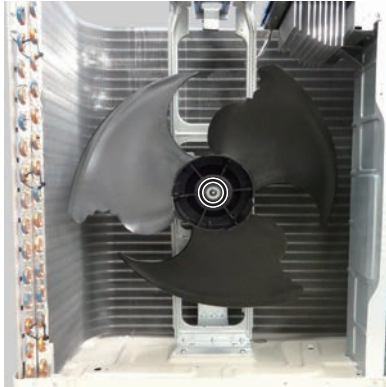

Note at the installation.  
Insert Propeller Fan and  
Motor Shaft reference  
D cutting position and  
Tightening torque is  
from 10 to 15N-m.

4. Remove the Hex socket screw.

5. Remove the Propeller Fan.
6. Remove the screws ( 4 places ).

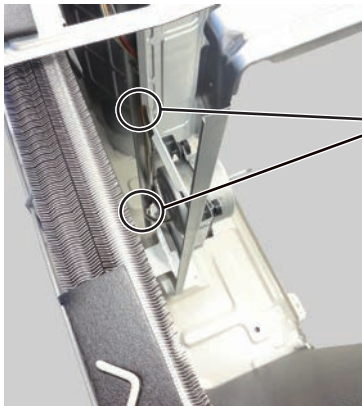

Hooks ( 2 places )

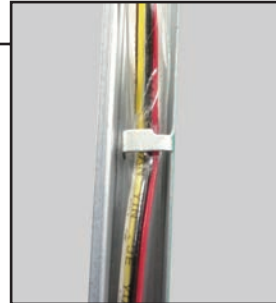

### 6. Side panel removal

Start from opening the Front panel and Valve and switch cover.



1. Remove the screws ( 9 places ).
2. Remove the Side panel.



**⚠ WARNING**

Before servicing the unit, turnings of all power supplies.  
Then, do not touch the electric parts for 10 minutes due to the risk of electric shock.

## 7. Thermistor removal

Start from removing the Side panel.

### Outdoor temperature thermistor removal

1. Disconnect the connector. ( P5 / White )
2. Release cables from cable guide.

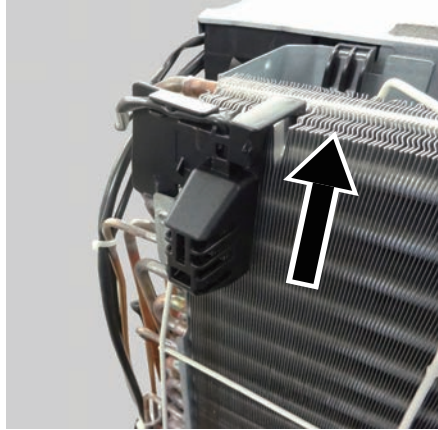
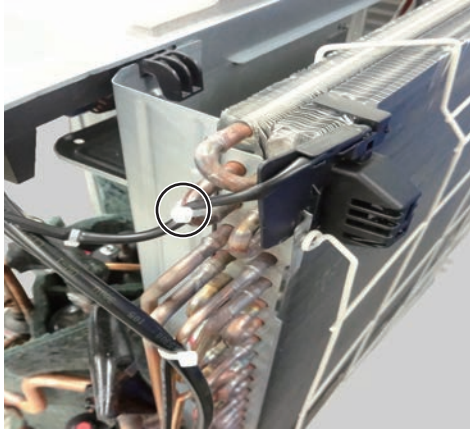

3. Cut binder.

4. Remove the Outdoor temperature thermistor as shown in the photo.

### Discharge and Pipe temperature thermistor removal

1. Disconnect the connector. ( P1 / Red )
2. Release cables from cable guide.

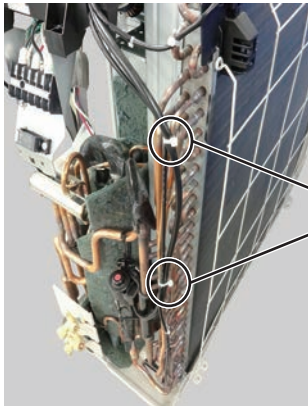

3. Cut binders. ( 2 places )

Pipe temperature thermistor

Discharge temperature thermistor

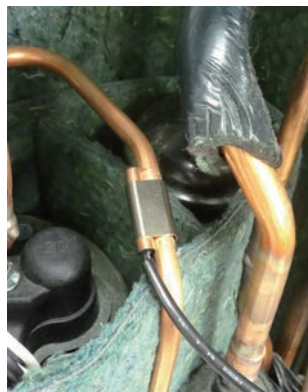

4. Remove the Pipe temperature thermistor as shown in the photo.  
Push the Thermistor spring. Discharge temperature thermistor is also the same.

**⚠ WARNING**

Before servicing the unit, turnings of all power supplies.  
Then, do not touch the electric parts for 10 minutes due to the risk of electric shock.

### 8. Solenoid coil removal

Start from removing the Front panel.

1. Disconnect the connector. ( P60 / Black )

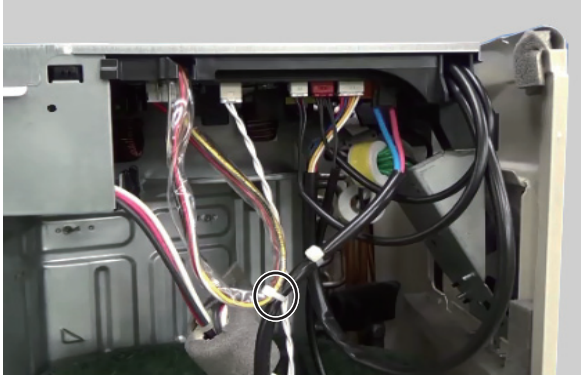

2. Cut binder.

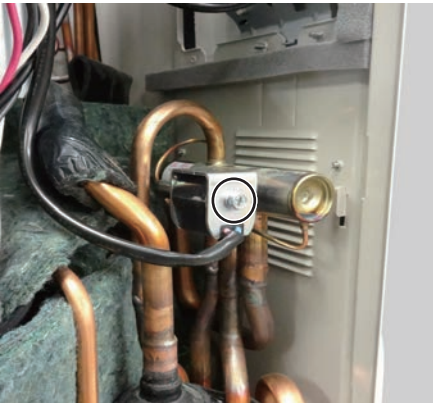

3. Remove the screw.



4. Remove the Solenoid coil as shown in the photo.

### 9. Electric expansion valve coil removal

Start from removing the Side panel.

1. Disconnect the connector. ( P30 / White )

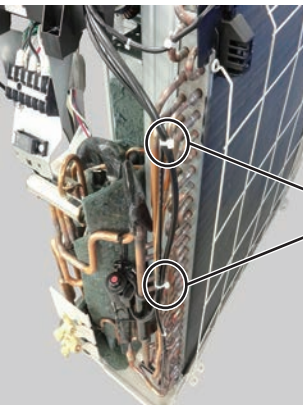

2. Cut binders. ( 2 places )

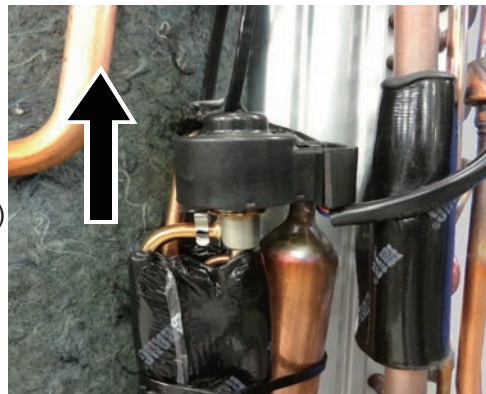

3. Remove the EEV coil as shown in the photo.

**⚠ WARNING**

Before servicing the unit, turn off all power supplies.  
Then, do not touch the electric parts for 10 minutes due to the risk of electric shock.

## 10. Compressor removal

### Precautions for exchange of compressor.

Do not allow moisture or debris to get inside refrigerant pipes during work.

### Procedure for compressor removal.

- (1) Turn off power.
- (2) Remove the Top panel and Front panel and Side panel.
- (3) Fully close the 3-way valve and 2-way valve.
- (4) Collect the refrigerant from the 3-way valve.  
Start the following work after completely collecting the refrigerant .  
Do not reuse the refrigerant that has been collected.

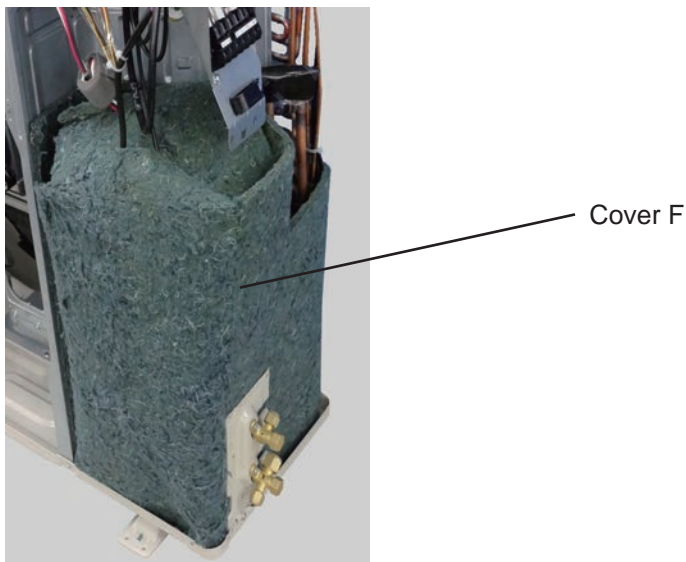

1. Remove the cover F.

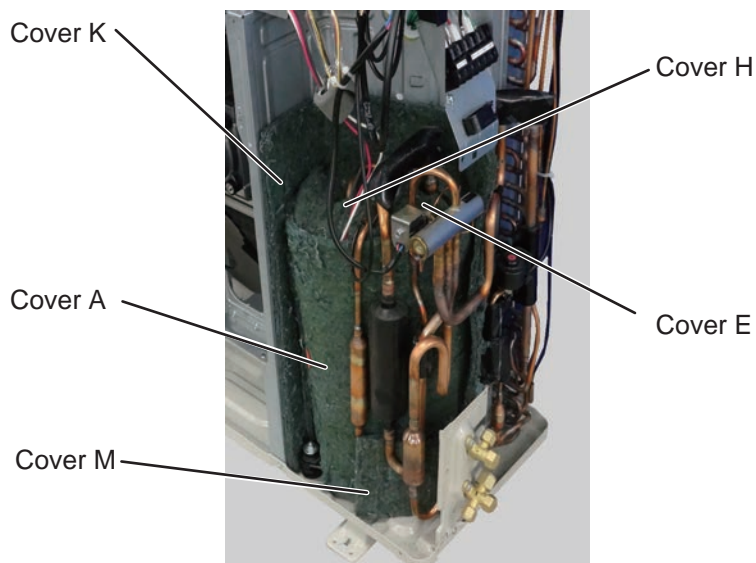

2. Remove the cover A, E, H, K, M. ( 5 covers )

**⚠ WARNING**

Before servicing the unit, turnings of all power supplies.  
Then, do not touch the electric parts for 10 minutes due to the risk of electric shock.



3. Remove the Hex socket screw and compressor terminal cover.



4. Remove the connectors.  
[ R : White, S : Red, C : Black ]



**(Tips!)**

Remove the Compressor bolts anticlockwise direction.

5. Remove the Compressor bolts. ( 3 places )

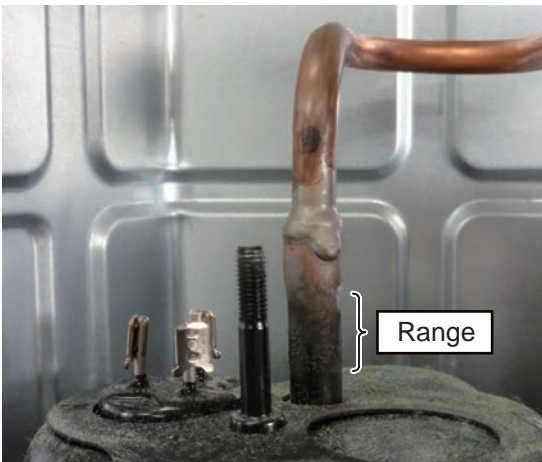

Cut the Discharge pipe in this range.

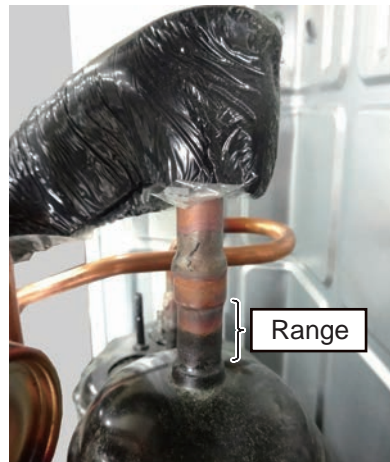

Cut the Suction pipe in this range.  
Remove the Compressor.

**CAUTION**

- Keep their shape better.
- There is a possibility of catching fire to oil when removing by the welding without cutting it.

**⚠ WARNING**

Before servicing the unit, turnings of all power supplies.  
Then, do not touch the electric parts for 10 minutes due to the risk of electric shock.

**Procedure for compressor installation.**

Reverse procedure to removing the compressor.

**Precautions for compressor installation.**

- (1) When welding, do not apply the flame to the terminal.
- (2) When welding, be sure to replace the air in the pipe with nitrogen gas to prevent forming oxidization scale.

**11. Precautions for exchange of refrigerant-cycle-parts**

- (1) During exchange the following parts shall be protected by wet rag and not make the allowable temperature or more.
- (2) Remove the heat insulation when there is the heat insulation near the welding place.  
Move and cool it when its detaching is difficult.
- (3) Cool the parts when there are parts where heat might be transmitted besides the replacement part.
- (4) Interrupt the flame with the fire-retardant board when the flame seems to hit the following parts directly.
- (5) Do not allow moisture or debris to get inside refrigerant pipes during work.
- (6) When brazing, be sure to replace the air in the pipe with nitrogen gas to prevent forming oxidization scale.

Part name	Allowable temperature	Precautions in work
EXPANSION VALVE	120°C	Remove the coil before brazing. And install the coil after brazing. Detaching necessity Sensor.
4WAY VALVE	120°C	Remove the suction temp. sensor before brazing. And install the suction temp. sensor after brazing.
3WAY VALVE (GAS)	100°C	
2WAY VALVE (LIQUID)		
HIGH PRESSURE SWITCH	100°C	

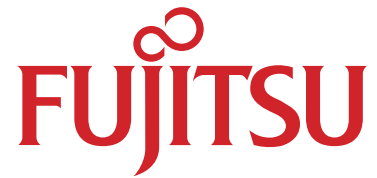

# FUJITSU GENERAL LIMITED

3-3-17, Suenaga, Takatsu-ku, Kawasaki 213-8502, Japan