



AIR CONDITIONER

Wall Mounted type

DESIGN & TECHNICAL MANUAL

INDOOR



AS*G07LECA
AS*G09LECA
AS*G12LECA



AS*G14LECA

OUTDOOR



AO*G07LEC
AO*G09LEC
AO*G12LEC



AO*G14LEC

FUJITSU GENERAL LIMITED

1. INDOOR UNIT

WALL MOUNTED TYPE :

AS*G07LECA

AS*G09LECA

AS*G12LECA

AS*G14LECA

CONTENTS

1. INDOOR UNIT

1. FEATURE	01 - 01
2. WIRELESS REMOTE CONTROLLER	01 - 04
3. SPECIFICATIONS	01 - 06
4. DIMENSIONS	01 - 07
5. WIRING DIAGRAMS	01 - 10
6. CAPACITY TABLE	01 - 11
6-1. COOLING CAPACITY.....	01 - 11
6-2. HEATING CAPACITY.....	01 - 12
7. FAN PERFORMANCE	01 - 13
7-1. AIR VELOCITY DISTRIBUTION.....	01 - 13
7-2. AIR FLOW.....	01 - 15
8. OPERATION NOISE	01 - 17
8-1. NOISE LEVEL CURVE.....	01 - 17
8-2. SOUND LEVEL CHECK POINT.....	01 - 19
9. ELECTRIC CHARACTERISTICS	01 - 20
10. SAFETY DEVICES	01 - 21
11. EXTERNAL INPUT & OUTPUT	01 - 22
11-1. EXTERNAL INPUT.....	01 - 22
11-2. EXTERNAL OUTPUT.....	01 - 24
12. FUNCTION SETTING	01 - 25
13. OPTIONAL PARTS	01 - 29

1. FEATURE

MODEL

AS*G07LECA / AO*G07LEC
 AS*G09LECA / AO*G09LEC
 AS*G12LECA / AO*G12LEC
 AS*G14LECA / AO*G14LEC



FEATURES

● Energy-Efficiency classification A
 Europe Energy-Efficiency classification A achieved

● ALL DC



a DC fan motor

b DC compressor

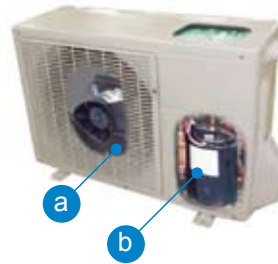

Front view

● Quiet operation

INDOOR UNIT

Air flow mode can be set in 4 steps and more detailed air flow setting is possible.

Fan speed	Noise level
Quiet	21dB(A)

(AS*G07/09/12LE)

OUTDOOR UNIT

Low noise mode

Introduction of a low outdoor noise operation mode allow the outdoor unit to have quiet mode operation setting.

* Performance may drop depending on the outside air temperature condition, etc.

Rated noise value -3dB

● 10°C HEAT Operation

The room temperature can be set to go no lower than 10°C, thus ensuring that the room does not get too cold when not occupied

Caution)

- When the room temperature is higher than 10°C, "10°C HEAT" operation does not start. Operation starts and maintains the room temperature at 10°C when the temperature drops below 10°C.

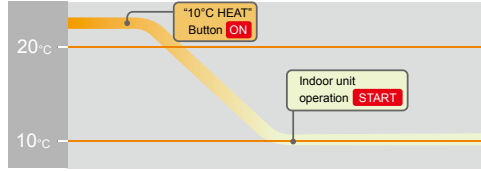

● Powerful operation

20 minutes continuous operation by maximum airflow and maximum compressor speed is possible. Rapid cooling and heating makes the room comfortable quickly.

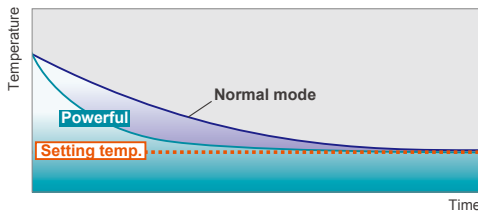

● Low outdoor air temperature correspondence

Corresponds to cooling operation at -10°C outdoor air temperature
Corresponds to heating operation at -15°C outdoor air temperature

Cooling	Heating
-10 to 43°C	-15 to 24°C

● Corresponds to maximum 20m long piping

● Air conditioner filter features



● Easy maintenance

Easy maintenance and always clean. Troublesome maintenance has been made easy.
Since the front panel is easy to remove, maintenance is also easy.



2. WIRELESS REMOTE CONTROLLER

■ FEATURES



- * Four kinds of timer setup (On / Off / Program / Sleep) are possible.
- * Four kinds of timers. Easy operation.
- * Easy to change transmission code (4 patterns) by button operation.

● Simple function setting

Setting of the air conditioner selection function is performed by remote controller.

● Built-in timers

Select from four different timer programs (On / Off / Program / Sleep).

● Program timer

The program timer operates the on and off timer once within a 24 hour period.

● Sleep timer

The sleep timer function automatically corrects the temperature thermostat setting according to the timer setting to prevent excessive cooling and heating while sleeping.

Cooling operation/dry operation

When the sleep timer is set, the set temperature automatically rises 1 °C every hour. The set temperature can rise up to a maximum of 2 °C.

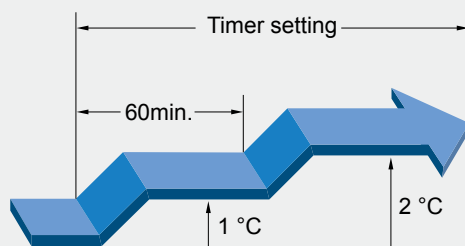

Heating operation

When the sleep timer is set, the set temperature automatically drops 1 °C every 30 minutes. The set temperature can drop to a maximum of 4 °C.

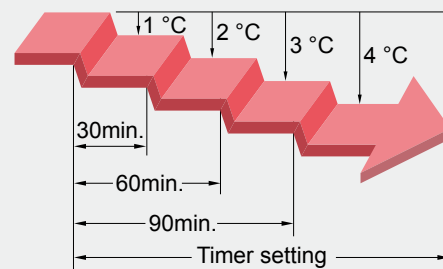

● Switching remote controller signal code

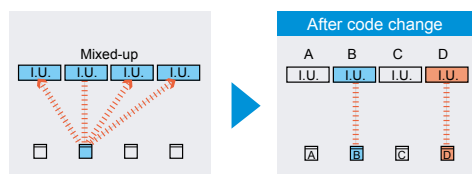

- Code selector switch eliminates unit being wrongly switched. (Up to 4 codes can be set.)

*I.U.=Indoor unit

FUNCTIONS

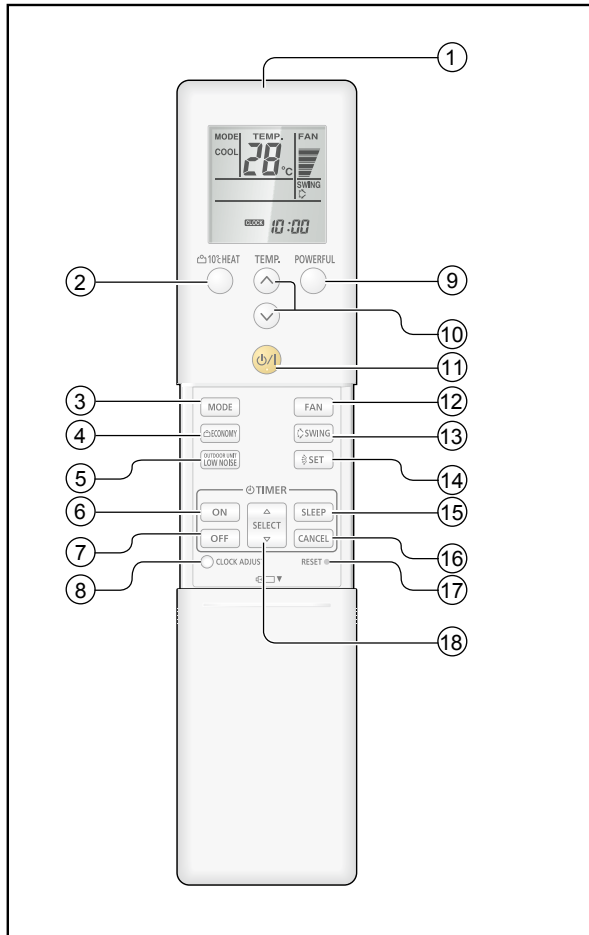

- ① Signal Transmitter
- ② 10 °C HEAT button
- ③ MODE button
- ④ ECONOMY button
- ⑤ OUTDOOR UNIT LOW NOISE button
- ⑥ ON TIMER button
- ⑦ OFF TIMER button
- ⑧ CLOCK ADJUST button
- ⑨ POWERFUL button
- ⑩ SET TEMP. button (▲ / ▼)
- ⑪ START/STOP button
- ⑫ FAN button
- ⑬ SWING button
- ⑭ SET button
- ⑮ SLEEP TIMER button
- ⑯ CANCEL button
- ⑰ RESET button
- ⑱ TIMER SET button (▲ / ▼)

Display panel

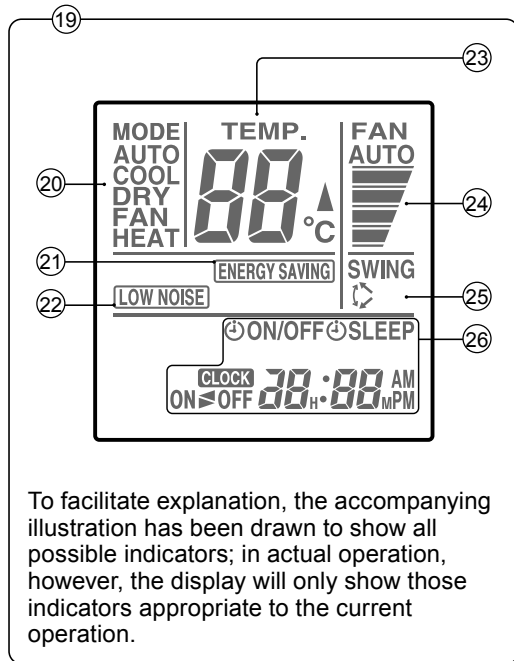

- ⑲ Remote Controller Display
- ⑳ Operation Mode Display
- ㉑ ENERGY SAVING MODE Display
- ㉒ LOW NOISE MODE Display
- ㉓ Temperature SET Display
- ㉔ FAN Speed Display
- ㉕ SWING Display
- ㉖ Clock & TIMER Display

SPECIFICATION

SIZE	(H x W x D mm)	205 x 61 x 17
WEIGHT	(g)	122
ACCESSORY		Holder

3. SPECIFICATIONS

Type				WALL MOUNTED INVERTER HEAT PUMP			
Model name				AS*G07LECA	AS*G09LECA	AS*G12LECA	AS*G14LECA
Power source				230V~ 50Hz			
Available voltage range				198-264V~ 50Hz			
European energy label				Cooling	A	A	A
				Heating	A	A	A
Capacity	Cooling	Rated	kW	2.10	2.50	3.40	4.00
			BTU/h	7,200	8,500	11,600	13,600
		Min-Max	kW	0.5~3.0	0.5~3.2	0.9~3.9	0.9~5.0
			BTU/h	1,700~10,200	1,700~10,900	3,100~13,300	3,100~17,100
	Heating	Rated	kW	3.00	3.20	4.00	5.00
			BTU/h	10,200	10,900	13,600	17,100
		Min-Max	kW	0.5~4.0	0.5~4.2	0.9~5.3	0.9~6.4
			BTU/h	1,700~13,600	1,700~14,300	3,100~18,000	3,100~21,800
Input power	Cooling	Rated	kW	0.47	0.64	0.92	1.105
				Min-Max	0.25~1.19	0.25~1.27	0.25~1.40
	Heating	Rated		0.685	0.75	0.99	1.305
				Min-Max	0.25~1.60	0.25~1.60	0.25~1.99
Current	Cooling	Rated	A	2.7	3.5	4.4	5.3
				Max	6.0	6.0	6.5
	Heating	Rated		3.5	3.8	4.7	6.0
				Max	7.5	7.5	9.0
EER	Cooling		kW/kW	4.47	3.91	3.70	3.62
COP	Heating		kW/kW	4.38	4.27	4.04	3.83
SENSIBLE CAPACITY	Cooling		kW	1.2	1.6	2.2	2.6
POWER FACTOR	Cooling		%	76	80	91	91
	Heating		%	85	86	92	94
Moisture removal				l/h(pints/h)	1.3 (2.3)	1.3 (2.3)	1.8 (3.2)
FAN	Airflow rate	Cooling	High	m ³ /h	690	770	
			Med		610	680	
			Low		440	540	
			Quiet		300	410	
		Heating	High		710	770	
			Med		610	680	
			Low		480	580	
			Quiet		310	420	
	Type× Q'ty		Cross flow fanx1				
	Motor output		W				
		30					
Sound pressure level	Cooling	High	dB(A)	43	44		
				Med	38	40	
				Low	31	33	
				Quiet	21	25	
	Heating	High		43	44		
				Med	38	40	
				Low	31	35	
				Quiet	21	27	
Heat exchanger type	Dimensions (H×W×D)		mm	256x630x20		320x630x20 Sub:84x630x13.3	
	Fin pitch			1.1	1.1		
	Rows Stages			2x16	2x20 Sub:1x4		
	Pipe type			Copper			
	Fin type			Aluminium			
Enclosure	Material		Polystyrene				
	Colour		White Approximate colour of MUNSELL N9.25/				
Dimensions (H×W×D)	Net		mm	260x790x198		260x790x203	
	Gross			259x840x328		263x840x375	
Weight	Net		kg(lbs.)	7.5(17)		8(18)	
	Gross			9.5(21)		10.5(23)	
Connection pipe	Size	Liquid	mm	Ø6.35(Ø1/4in)			
		Gas		Ø9.52(Ø3/8in)		Ø12.7(Ø1/2in)	
	Method			Flare			
Operation range	Cooling	°C	18 to 32				
		%RH	80 or less				
	Heating	°C	30 or less				
Remote controller type				Wireless			
Drain pipe	Material		PP+LLDPE				
	Size		mm				
				Outer diameter:21/Outer diameter:13.6			

Note:

Specifications are based on the following conditions

Cooling:Indoor temperature of 27°C CDB/19°C CWB and outdoor temperature of 35°C CDB/24°C CWB.

Heating:Indoor temperature of 20°C CDB/15°C CWB and outdoor temperature of 7°C CDB/6°C CWB.

Pipe length:5m,Height difference:0m(Outdoor unit-Indoor unit)

The maximum current is the maximum value when the operated within the operation range(temperature).

■ MODEL: AS*G14LE

(Unit : mm)

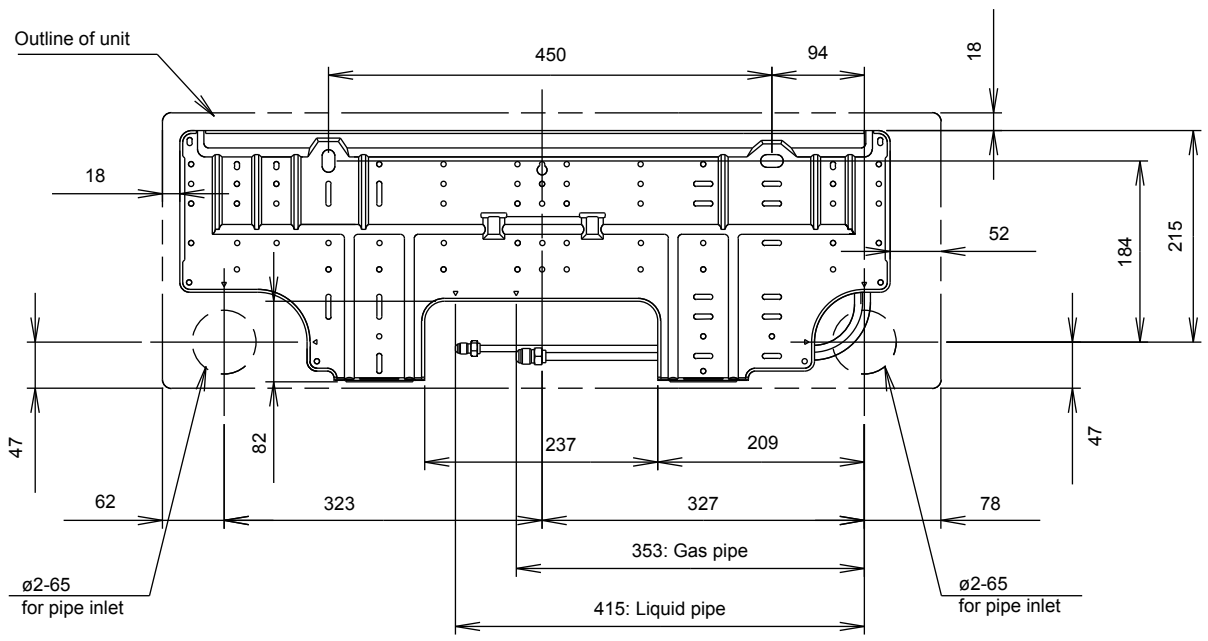
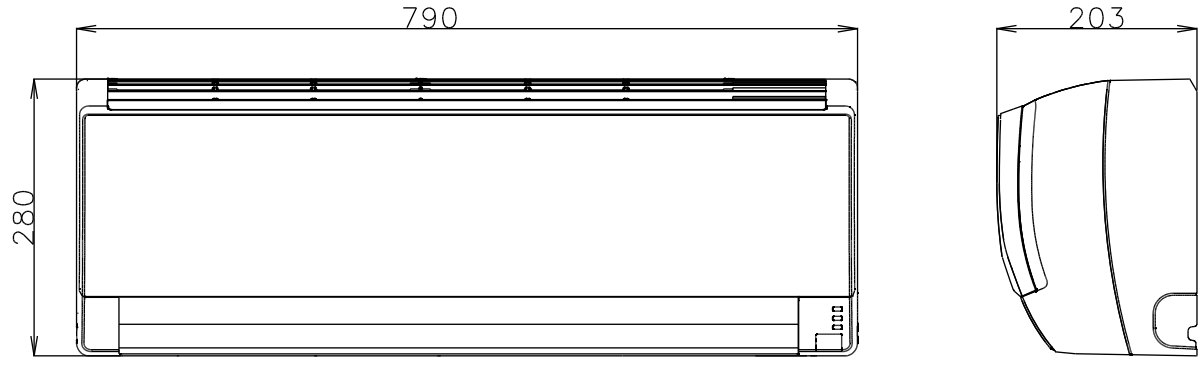

■ INSTALLATION PLACE

(Unit : mm)

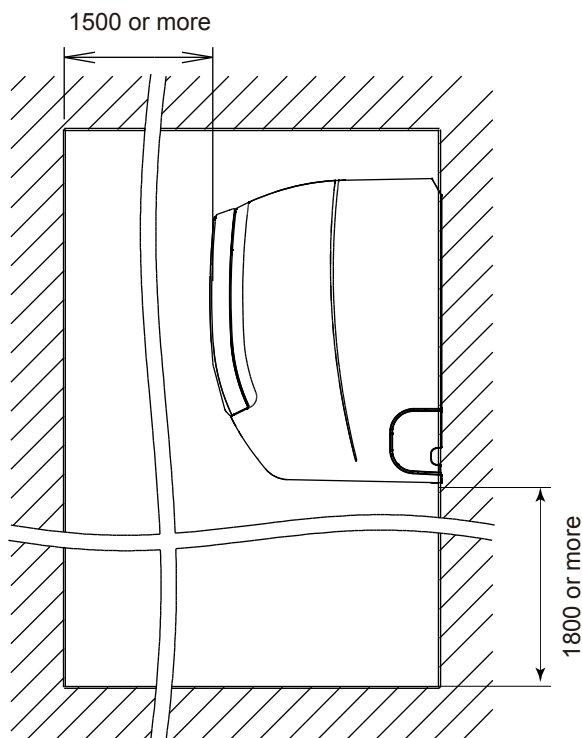
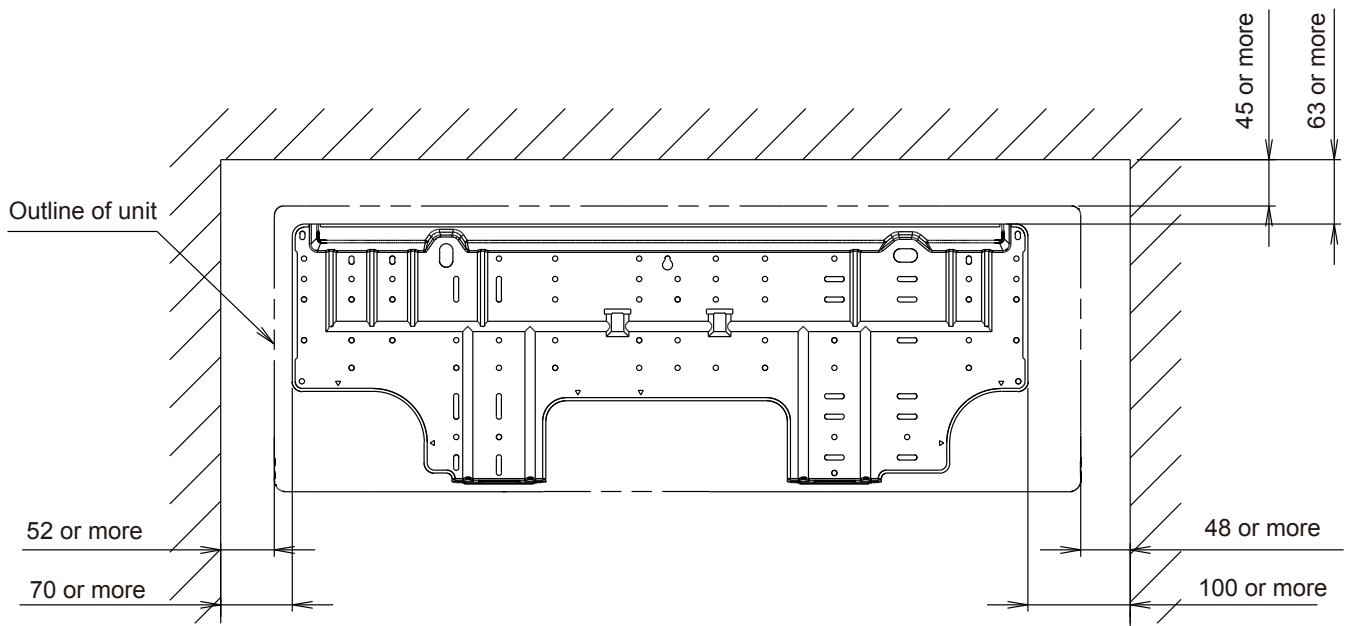

5. WIRING DIAGRAMS

■ MODEL: AS*G07LE, AS*G09LE, AS*G12LE, AS*G14LE

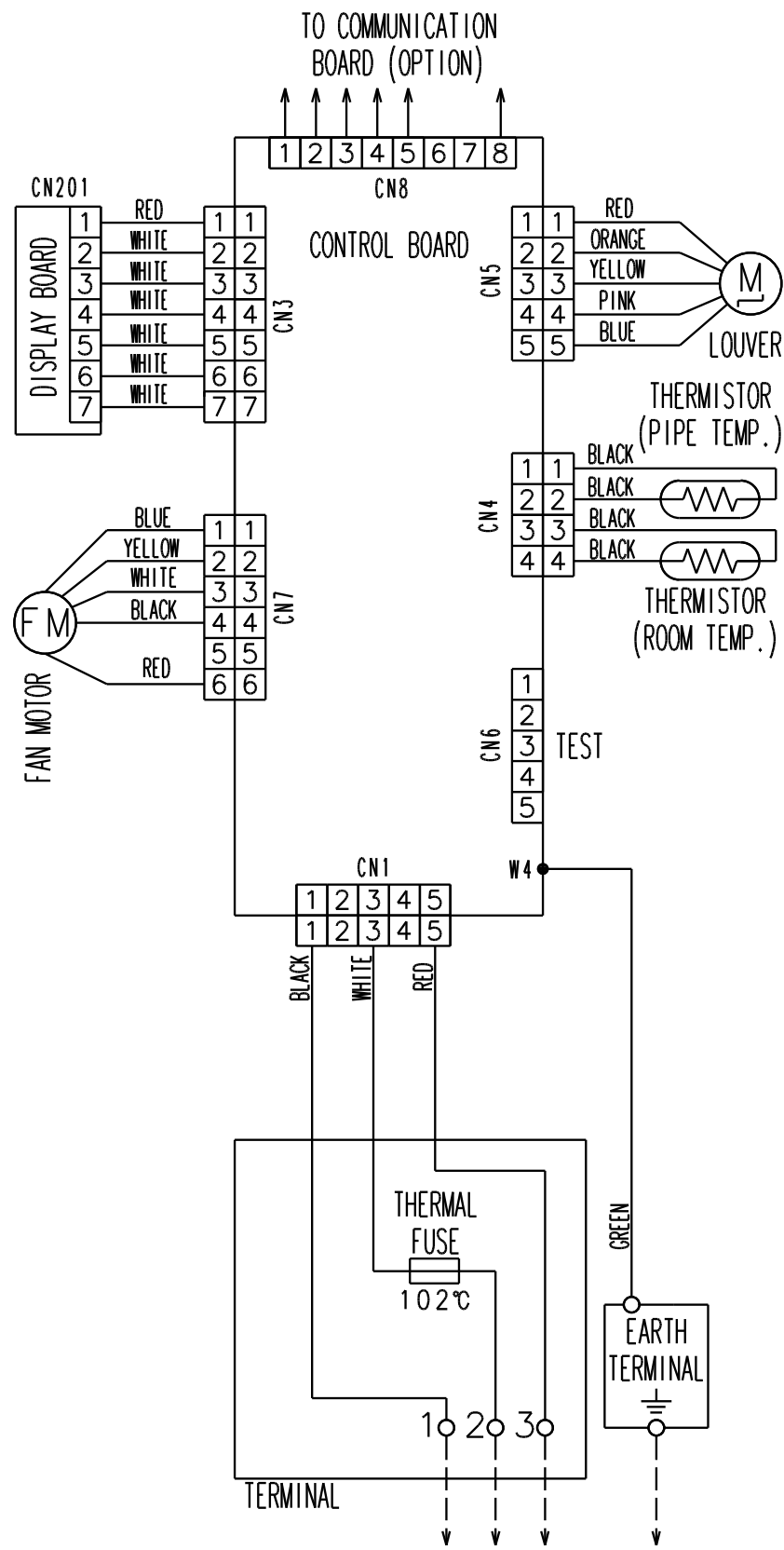

6. CAPACITY TABLE

6-1. COOLING CAPACITY

MODEL: AS*G07LE

AFR	11.5
-----	------

		Indoor temperature																							
		°CDB			18			21			23			25			27			29			32		
		°CWB			12			15			16			18			19			21			23		
Outdoor temperature	°CDB	TC	SHC	IP	TC	SHC	IP	TC	SHC	IP	TC	SHC	IP	TC	SHC	IP	TC	SHC	IP	TC	SHC	IP			
	20	1.97	1.22	0.33	2.19	1.23	0.34	2.26	1.33	0.34	2.41	1.34	0.34	2.49	1.45	0.34	2.64	1.44	0.35	2.79	1.53	0.35			
	25	1.87	1.16	0.37	2.08	1.17	0.38	2.15	1.27	0.38	2.29	1.27	0.38	2.36	1.37	0.38	2.50	1.37	0.39	2.65	1.46	0.39			
	30	1.76	1.10	0.41	1.97	1.10	0.42	2.03	1.20	0.42	2.17	1.20	0.42	2.23	1.30	0.43	2.37	1.29	0.43	2.50	1.38	0.44			
	35	1.66	1.03	0.45	1.85	1.04	0.46	1.91	1.13	0.46	2.04	1.13	0.47	2.10	1.22	0.47	2.23	1.22	0.47	2.35	1.29	0.48			
	40	1.48	0.92	0.45	1.65	0.92	0.46	1.70	1.00	0.46	1.82	1.01	0.47	1.87	1.09	0.47	1.98	1.08	0.47	2.10	1.15	0.48			
	43	1.37	0.85	0.45	1.53	0.86	0.46	1.58	0.93	0.46	1.68	0.93	0.47	1.74	1.01	0.47	1.84	1.00	0.47	1.94	1.07	0.48			

MODEL: AS*G09LE

AFR	11.5
-----	------

		Indoor temperature																							
		°CDB			18			21			23			25			27			29			32		
		°CWB			12			15			16			18			19			21			23		
Outdoor temperature	°CDB	TC	SHC	IP	TC	SHC	IP	TC	SHC	IP	TC	SHC	IP	TC	SHC	IP	TC	SHC	IP	TC	SHC	IP			
	20	2.34	1.62	0.45	2.61	1.63	0.46	2.70	1.77	0.46	2.87	1.78	0.46	2.96	1.92	0.47	3.14	1.91	0.47	3.32	2.04	0.48			
	25	2.22	1.54	0.50	2.48	1.55	0.51	2.56	1.68	0.52	2.73	1.69	0.52	2.81	1.82	0.52	2.98	1.82	0.53	3.15	1.93	0.53			
	30	2.10	1.45	0.56	2.34	1.46	0.57	2.42	1.59	0.57	2.58	1.60	0.58	2.66	1.72	0.58	2.82	1.72	0.59	2.98	1.83	0.59			
	35	1.98	1.37	0.62	2.20	1.38	0.63	2.28	1.50	0.63	2.43	1.50	0.64	2.50	1.62	0.64	2.65	1.61	0.65	2.80	1.72	0.65			
	40	1.76	1.22	0.62	1.96	1.23	0.63	2.03	1.33	0.63	2.16	1.34	0.64	2.23	1.44	0.64	2.36	1.44	0.65	2.50	1.53	0.65			
	43	1.63	1.13	0.62	1.82	1.14	0.62	1.88	1.24	0.63	2.00	1.24	0.63	2.07	1.34	0.64	2.19	1.33	0.64	2.31	1.42	0.65			

MODEL: AS*G12LE

AFR	11.5
-----	------

		Indoor temperature																							
		°CDB			18			21			23			25			27			29			32		
		°CWB			12			15			16			18			19			21			23		
Outdoor temperature	°CDB	TC	SHC	IP	TC	SHC	IP	TC	SHC	IP	TC	SHC	IP	TC	SHC	IP	TC	SHC	IP	TC	SHC	IP			
	20	3.18	2.18	0.63	3.55	2.19	0.64	3.67	2.38	0.64	3.91	2.39	0.65	4.03	2.58	0.65	4.27	2.57	0.66	4.51	2.74	0.67			
	25	3.03	2.08	0.72	3.37	2.09	0.73	3.49	2.27	0.73	3.72	2.28	0.74	3.83	2.46	0.74	4.06	2.45	0.75	4.29	2.61	0.76			
	30	2.86	1.96	0.80	3.19	1.97	0.81	3.30	2.15	0.82	3.52	2.15	0.82	3.63	2.32	0.83	3.84	2.32	0.84	4.06	2.47	0.85			
	35	2.69	1.84	0.89	2.99	1.85	0.90	3.09	2.01	0.91	3.30	2.02	0.92	3.40	2.18	0.92	3.60	2.17	0.93	3.81	2.31	0.94			
	40	2.27	1.56	0.83	2.53	1.57	0.84	2.62	1.70	0.84	2.79	1.71	0.85	2.87	1.84	0.86	3.05	1.84	0.86	3.22	1.96	0.87			
	43	2.09	1.43	0.83	2.33	1.44	0.84	2.41	1.57	0.84	2.57	1.57	0.85	2.65	1.70	0.86	2.81	1.69	0.87	2.96	1.80	0.87			

MODEL: AS*G14LE

AFR	12.8
-----	------

		Indoor temperature																							
		°CDB			18			21			23			25			27			29			32		
		°CWB			12			15			16			18			19			21			23		
Outdoor temperature	°CDB	TC	SHC	IP	TC	SHC	IP	TC	SHC	IP	TC	SHC	IP	TC	SHC	IP	TC	SHC	IP	TC	SHC	IP			
	20	3.72	2.58	0.77	4.14	2.60	0.78	4.29	2.83	0.79	4.57	2.83	0.79	4.71	3.06	0.80	4.99	3.05	0.81	5.28	3.25	0.81			
	25	3.55	2.46	0.87	3.95	2.48	0.88	4.08	2.69	0.89	4.35	2.70	0.89	4.49	2.92	0.90	4.76	2.91	0.91	5.03	3.10	0.92			
	30	3.36	2.34	0.97	3.75	2.35	0.98	3.87	2.55	0.99	4.13	2.56	1.00	4.26	2.77	1.00	4.51	2.76	1.01	4.77	2.94	1.02			
	35	3.16	2.19	1.07	3.52	2.21	1.08	3.64	2.40	1.09	3.88	2.41	1.10	4.00	2.60	1.11	4.24	2.59	1.12	4.48	2.76	1.13			
	40	2.78	1.93	1.05	3.09	1.94	1.07	3.20	2.11	1.07	3.41	2.12	1.08	3.51	2.28	1.09	3.73	2.28	1.10	3.94	2.42	1.11			
	43	2.53	1.76	1.03	2.82	1.77	1.05	2.91	1.92	1.06	3.11	1.93	1.07	3.20	2.08	1.07	3.39	2.07	1.08	3.59	2.21	1.09			

AFR : Air flow rate (m³/min)
 TC : Total capacity (kW)
 SHC : Sensible Heat capacity (kW)
 IP : Input Power (kW)

6-2. HEATING CAPACITY

■ MODEL: AS*G07LE

AFR	11.8
-----	------

Outdoor temperature		Indoor temperature											
		°CDB)		16		18		20		22		24	
		(°CDB)	(°CWB)	TC	IP	TC	IP	TC	IP	TC	IP	TC	IP
-15	-16	2.25	0.99	2.19	1.01	2.14	1.03	2.09	1.05	2.03	1.07		
-10	-11	2.56	1.02	2.50	1.04	2.43	1.06	2.37	1.08	2.31	1.11		
-5	-7	2.93	1.05	2.86	1.07	2.79	1.10	2.72	1.12	2.65	1.14		
0	-2	3.47	1.09	3.39	1.12	3.31	1.14	3.23	1.16	3.14	1.19		
5	3	4.05	1.15	3.96	1.17	3.86	1.19	3.76	1.22	3.67	1.24		
7	6	4.20	1.17	4.10	1.20	4.00	1.22	3.90	1.25	3.80	1.27		
10	8	4.42	1.19	4.31	1.21	4.21	1.24	4.10	1.26	4.00	1.29		
15	10	4.58	1.18	4.47	1.20	4.36	1.23	4.25	1.25	4.14	1.27		

■ MODEL: AS*G09LE

AFR	11.8
-----	------

Outdoor temperature		Indoor temperature											
		°CDB)		16		18		20		22		24	
		(°CDB)	(°CWB)	TC	IP	TC	IP	TC	IP	TC	IP	TC	IP
-15	-16	2.25	0.99	2.19	1.01	2.14	1.03	2.09	1.05	2.03	1.07		
-10	-11	2.56	1.02	2.50	1.04	2.43	1.06	2.37	1.08	2.31	1.11		
-5	-7	2.93	1.05	2.86	1.07	2.79	1.10	2.72	1.12	2.65	1.14		
0	-2	3.47	1.09	3.39	1.12	3.31	1.14	3.23	1.16	3.14	1.19		
5	3	4.05	1.15	3.96	1.17	3.86	1.19	3.76	1.22	3.67	1.24		
7	6	4.41	1.17	4.31	1.20	4.20	1.22	4.10	1.25	3.99	1.27		
10	8	4.64	1.19	4.53	1.21	4.42	1.24	4.31	1.26	4.20	1.29		
15	10	4.81	1.18	4.69	1.20	4.58	1.23	4.46	1.25	4.35	1.27		

■ MODEL: AS*G12LE

AFR	11.8
-----	------

Outdoor temperature		Indoor temperature											
		°CDB)		16		18		20		22		24	
		(°CDB)	(°CWB)	TC	IP	TC	IP	TC	IP	TC	IP	TC	IP
-15	-16	3.40	1.72	3.32	1.76	3.24	1.80	3.16	1.83	3.07	1.87		
-10	-11	3.76	1.72	3.67	1.76	3.58	1.79	3.49	1.83	3.40	1.86		
-5	-7	4.18	1.72	4.08	1.76	3.98	1.79	3.88	1.83	3.78	1.87		
0	-2	4.68	1.72	4.57	1.76	4.46	1.80	4.35	1.83	4.24	1.87		
5	3	5.05	1.52	4.93	1.55	4.81	1.58	4.69	1.61	4.57	1.64		
7	6	5.36	1.51	5.23	1.54	5.10	1.57	4.97	1.60	4.85	1.63		
10	8	5.55	1.51	5.42	1.54	5.29	1.57	5.16	1.60	5.02	1.63		
15	10	5.54	1.41	5.41	1.44	5.28	1.47	5.15	1.50	5.01	1.53		

■ MODEL: AS*G14LE

AFR	12.8
-----	------

Outdoor temperature		Indoor temperature											
		°CDB)		16		18		20		22		24	
		(°CDB)	(°CWB)	TC	IP	TC	IP	TC	IP	TC	IP	TC	IP
-15	-16	3.47	1.78	3.39	1.81	3.30	1.85	3.22	1.89	3.14	1.93		
-10	-11	4.15	1.87	4.05	1.91	3.95	1.95	3.85	1.99	3.76	2.03		
-5	-7	4.78	1.97	4.67	2.01	4.55	2.06	4.44	2.10	4.33	2.14		
0	-2	5.59	2.07	5.46	2.11	5.32	2.16	5.19	2.20	5.06	2.24		
5	3	6.40	2.17	6.24	2.21	6.09	2.26	5.94	2.30	5.79	2.35		
7	6	6.72	1.80	6.56	1.83	6.40	1.87	6.24	1.91	6.08	1.94		
10	8	7.14	1.80	6.97	1.84	6.80	1.88	6.63	1.92	6.46	1.96		
15	10	7.46	1.81	7.28	1.85	7.11	1.89	6.93	1.93	6.75	1.97		

AFR : Air flow rate (m³/min)
TC : Total capacity (kW)
IP : Input Power (kW)

7. FAN PERFORMANCE

7-1. AIR VELOCITY DISTRIBUTION

■ MODEL: AS*G07LE, AS*G09LE, AS*G12LE

Note:
Fan speed : High
Operation mode : FAN

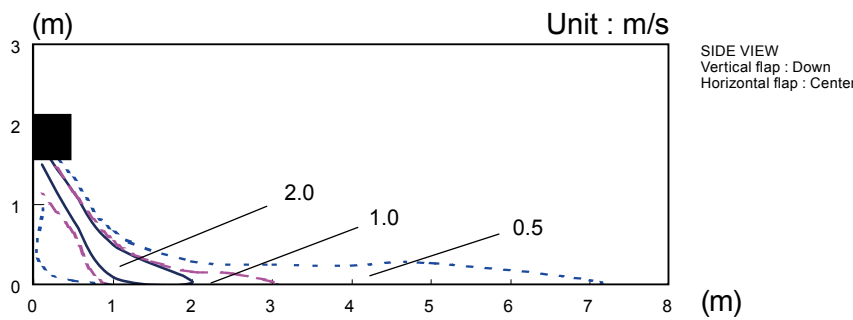
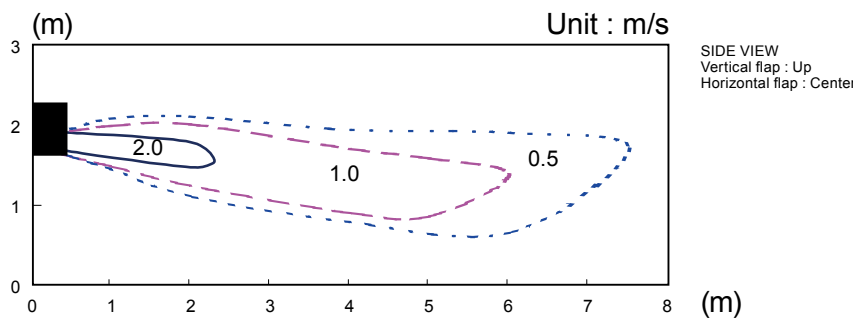
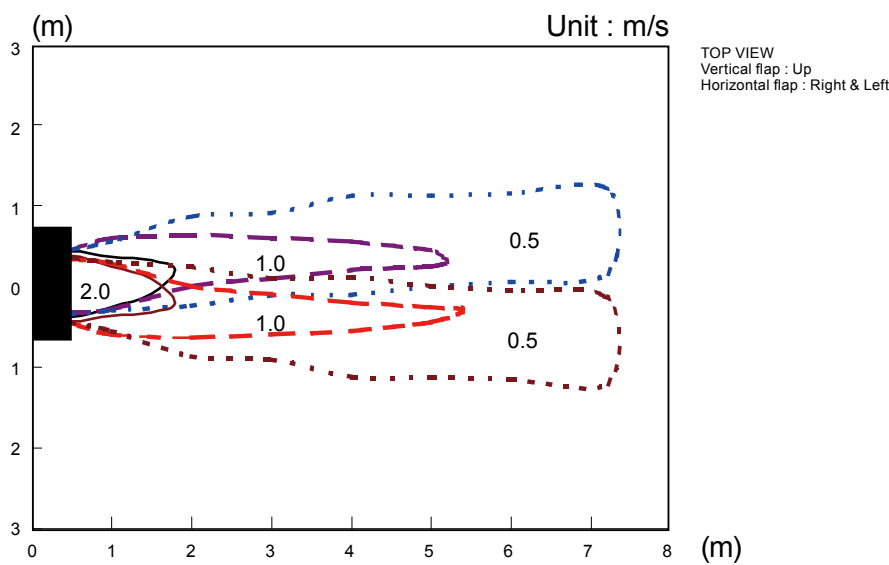
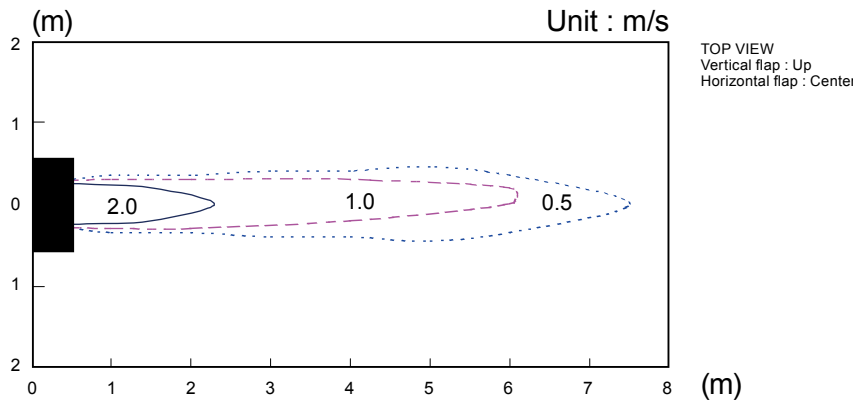

Note:
Fan speed : High
Operation mode : FAN

■ MODEL: AS*G14LE

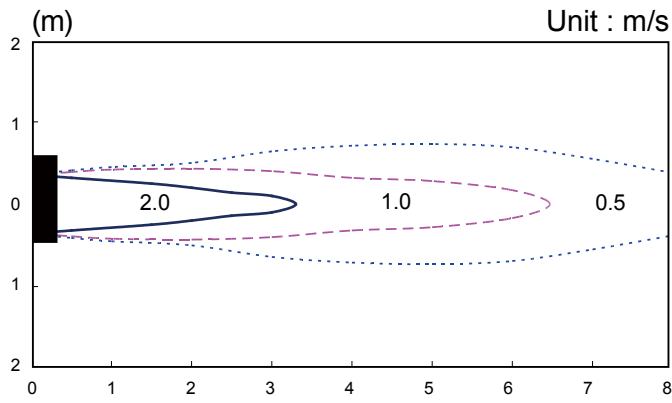

(m)

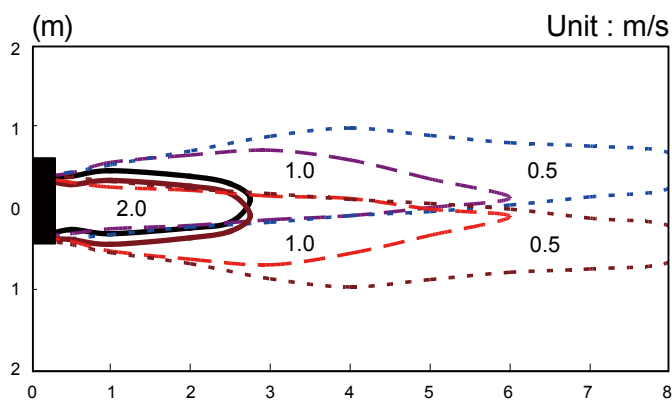

(m)

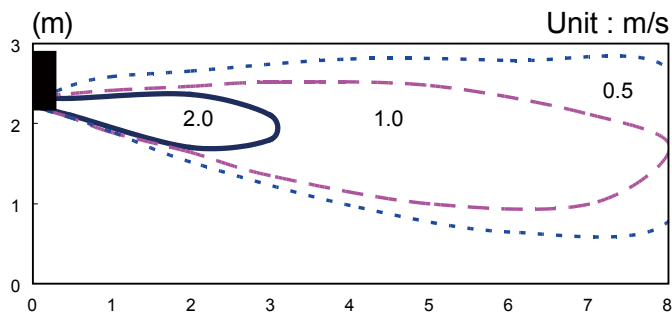

(m)

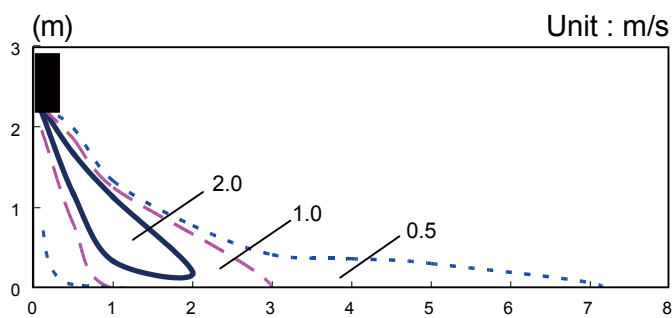

(m)

7-2. AIR FLOW

■ MODEL: AS*G07LE, AS*G09LE, AS*G12LE

● Cooling

Fan speed	Number of rotations (r.p.m.)	Air flow	
HIGH	1400	690	m ³ /h
		191	l/s
		406	CFM
MED	1200	610	m ³ /h
		169	l/s
		359	CFM
LOW	920	440	m ³ /h
		122	l/s
		259	CFM
QUIET	620	300	m ³ /h
		83	l/s
		176	CFM

● Heating

Fan speed	Number of rotations (r.p.m.)	Air flow	
HIGH	1440	710	m ³ /h
		197	l/s
		417	CFM
MED	1200	610	m ³ /h
		169	l/s
		359	CFM
LOW	980	480	m ³ /h
		133	l/s
		282	CFM
QUIET	670	310	m ³ /h
		86	l/s
		182	CFM

■ MODEL: AS*G14LE

● Cooling

Fan speed	Number of rotations (r.p.m.)	Air flow	
HIGH	1400	770	m ³ /h
		213	l/s
		453	CFM
MED	1230	680	m ³ /h
		188	l/s
		400	CFM
LOW	1000	540	m ³ /h
		150	l/s
		318	CFM
QUIET	750	410	m ³ /h
		114	l/s
		241	CFM

● Heating

Fan speed	Number of rotations (r.p.m.)	Air flow	
HIGH	1400	770	m ³ /h
		213	l/s
		453	CFM
MED	1230	680	m ³ /h
		188	l/s
		400	CFM
LOW	1050	580	m ³ /h
		161	l/s
		341	CFM
QUIET	770	420	m ³ /h
		116	l/s
		247	CFM

8. OPERATION NOISE

8-1. NOISE LEVEL CURVE

MODEL: AS*G07LE

● Cooling

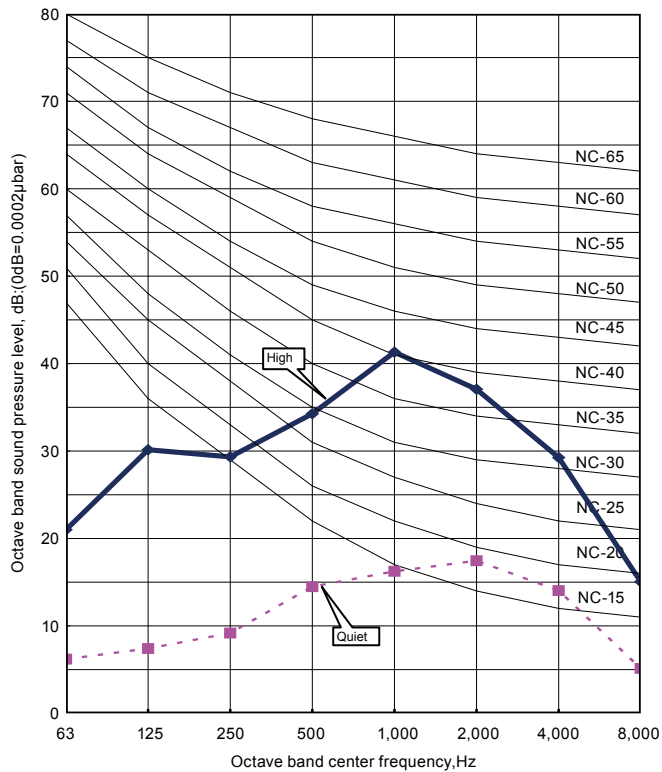

● Heating

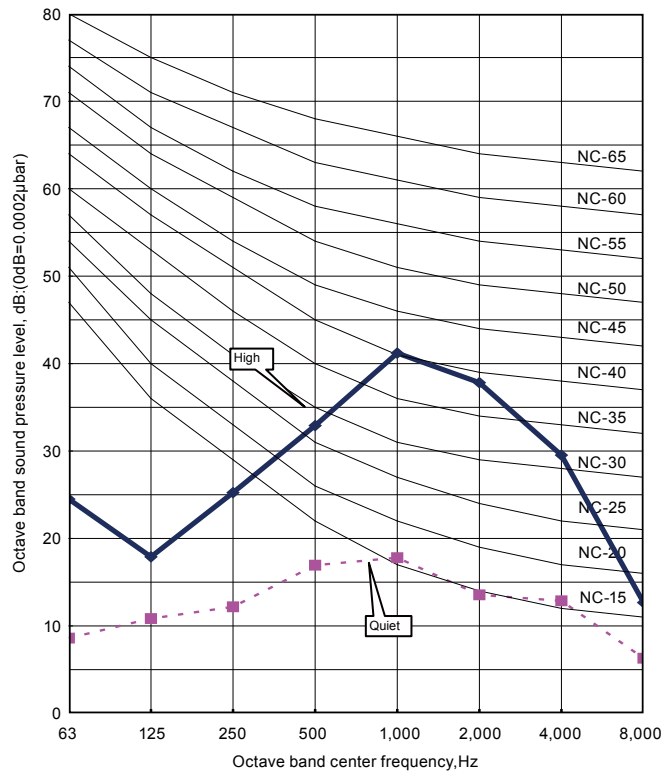

MODEL: AS*G09LE

● Cooling

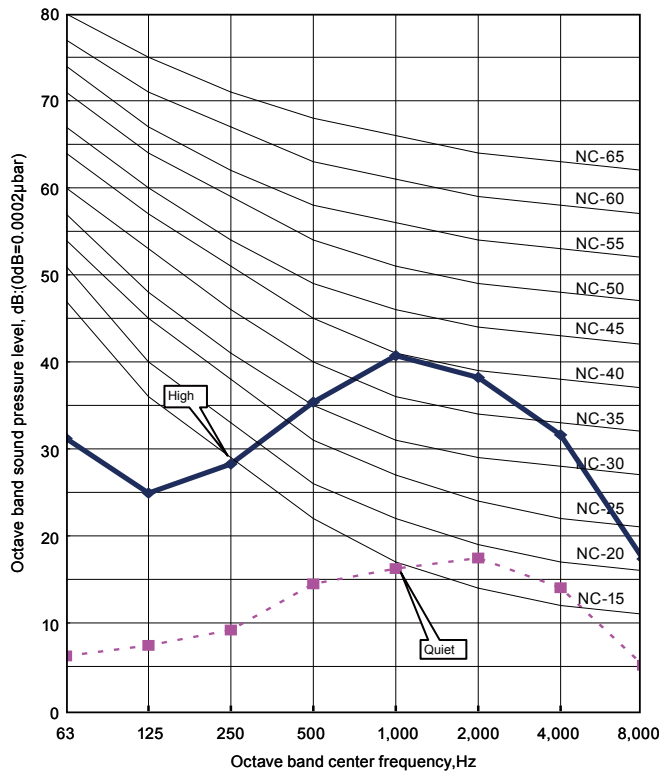

● Heating

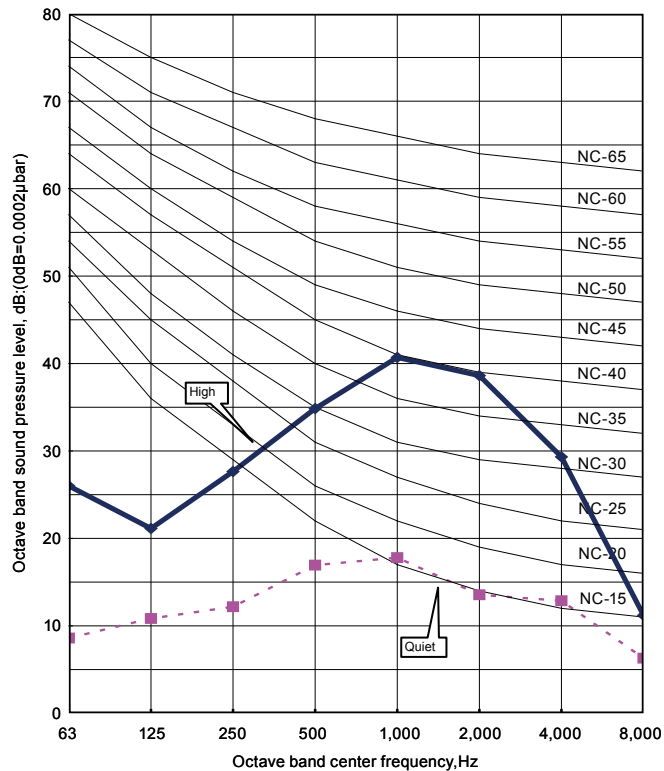

MODEL: AS*G12LE

● Cooling

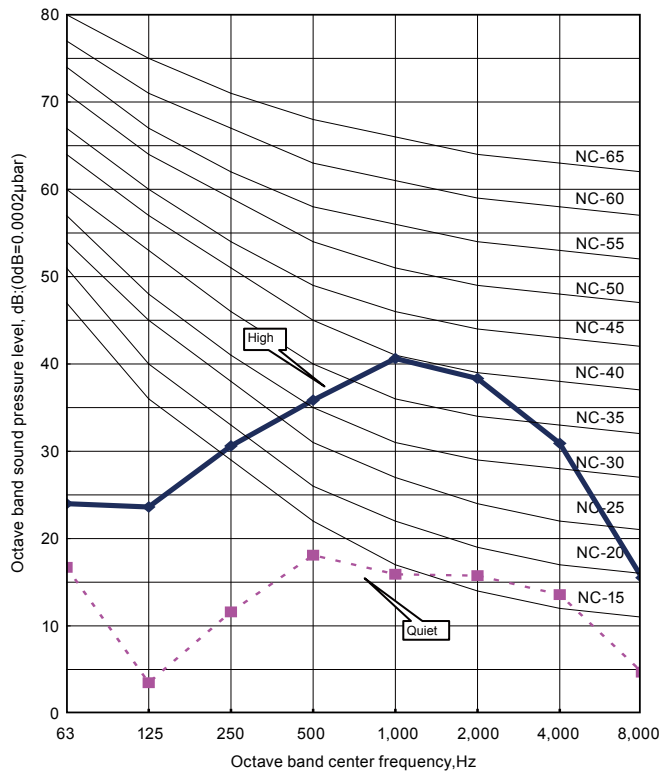

● Heating

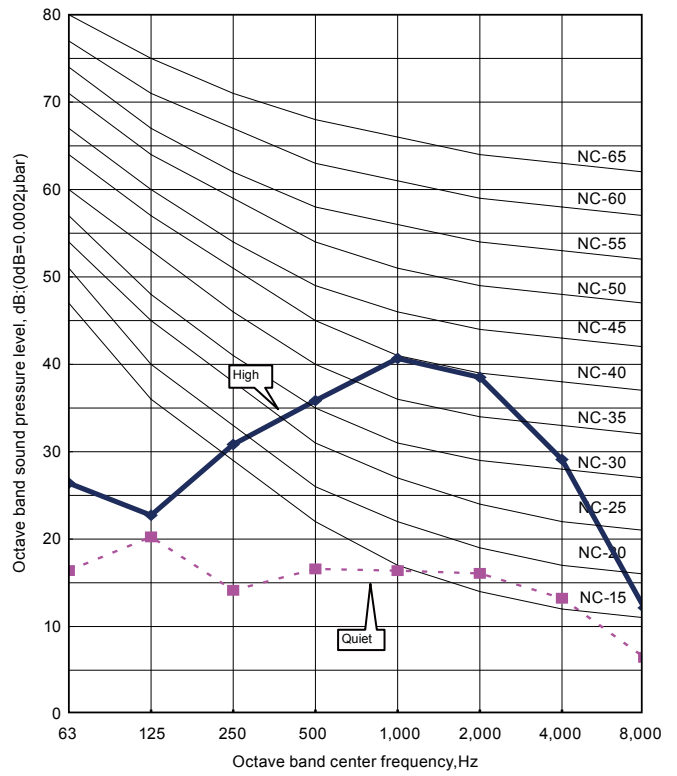

MODEL: AS*G14LE

● Cooling

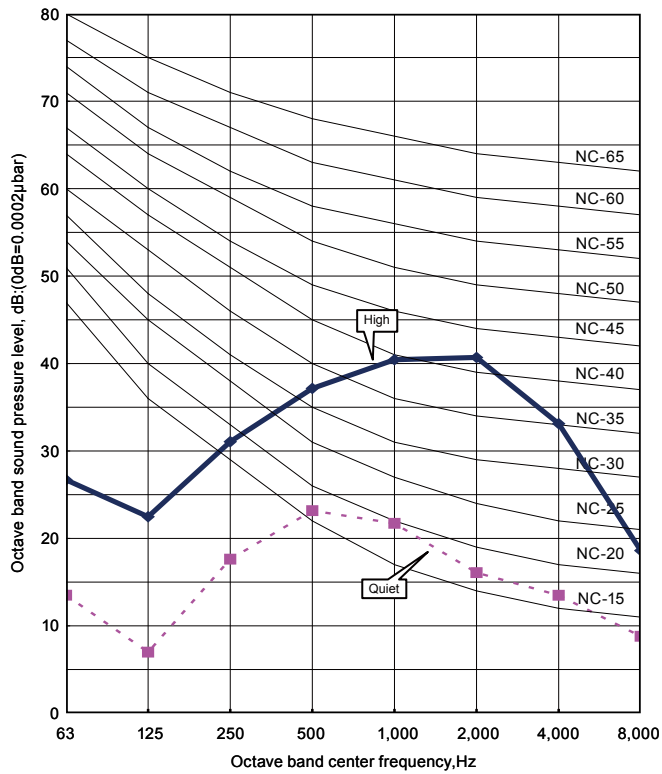

● Heating

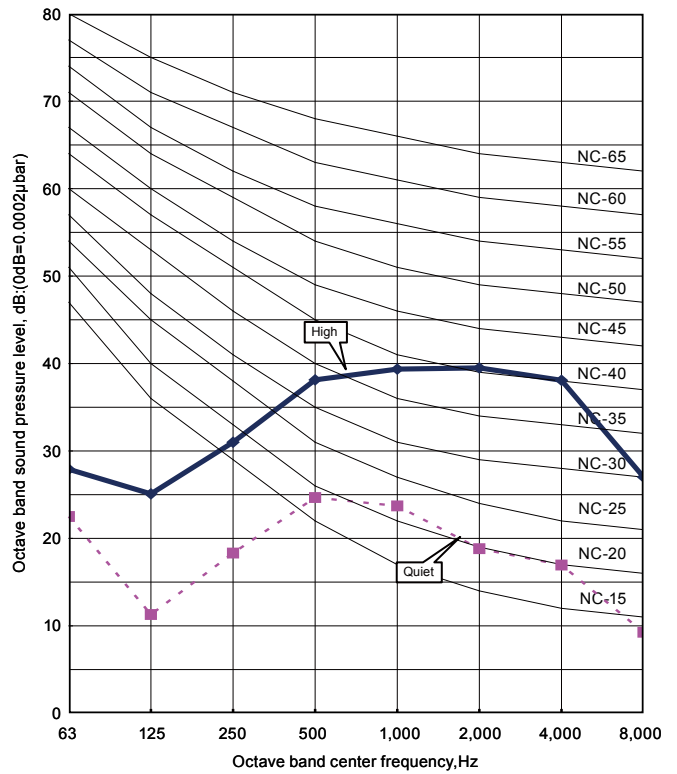

8-2. SOUND LEVEL CHECK POINT

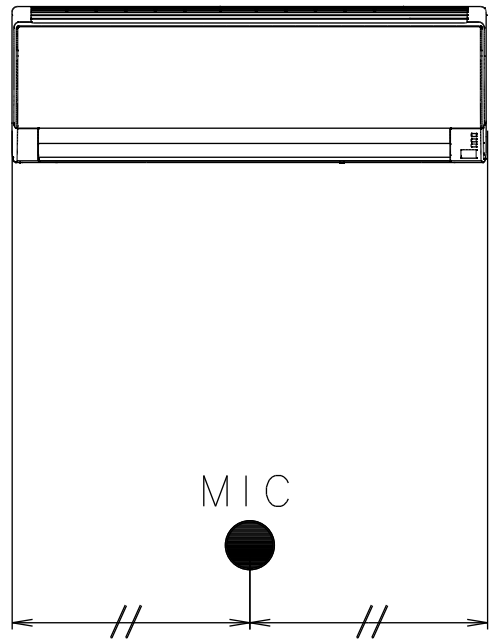
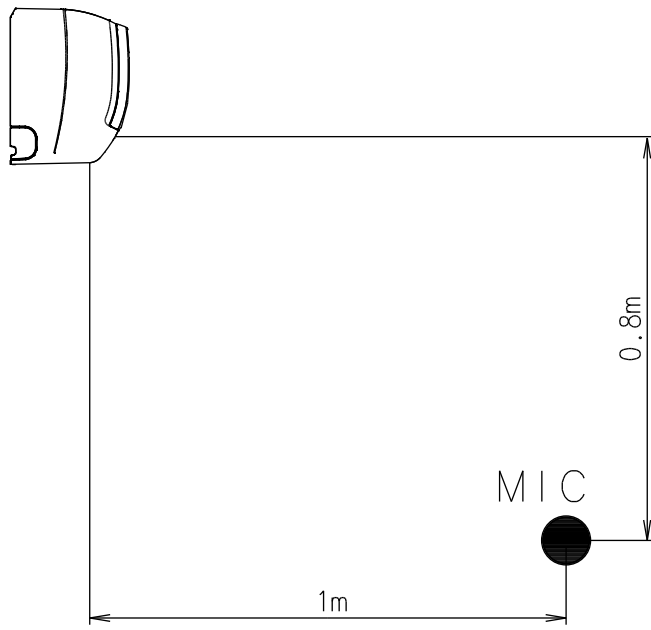

9. ELECTRIC CHARACTERISTICS

Model name			AS*G07LE	AS*G09LE	AS*G12LE	AS*G14LE
Power supply	Voltage	V	230~			
	Frequency	Hz	50			
Max. operating current		A	0.4			
*1)Wiring Spec.	Connection cable	mm ²	1.0-1.5			1.5
	Limited wiring length	m	21			

*1) Wiring Spec.

Selected Sample

(Selected based on Japan Electrotechnical Standard and Codes Committee E0005)

10. SAFETY DEVICES

	Protection form	Model
		AS*G07LE AS*G09LE AS*G12LE AS*G14LE
Circuit protection	Current fuse (PCB)	3.15A 250V
Terminal protection	Current (thermal) fuse	3A 250V
Fan motor protection	Thermal protector program	100 ⁺¹⁵ ₋₁₀ °C OFF 95 ⁺⁵ ₋₁₀ °C ON

11. EXTERNAL INPUT & OUTPUT

Connector	INPUT	OUTPUT	REMARKS
CN303	Control input	-	See external input/output settings for details.
CN304	-	Operation status output	

11-1. EXTERNAL INPUT

■ CONTROL INPUT (Operation/Stop or Forced stop)

The air conditioner can be remotely operated by means of the following on-site work.

"Operation/Stop" mode or "Forced stop" mode can be selected with function setting of indoor unit.

Operation is started at the following contents by adding the contact input of a commercial ON/OFF switch to a connector on the external control PC board and turning it ON.

	Initial starting after power turned on	Starting other than at the left
Operation mode	Auto changeover	Mode at previous operation
Set temperature	24°C	Temperature at previous operation
Air flow mode	AUTO	Mode at previous operation
Up-down air direction (swing)	Standard air direction (swing OFF)	Air direction at previous operation
Left-right air direction (swing)	Standard air direction (swing OFF)	Air direction at previous operation

● Circuit diagram example

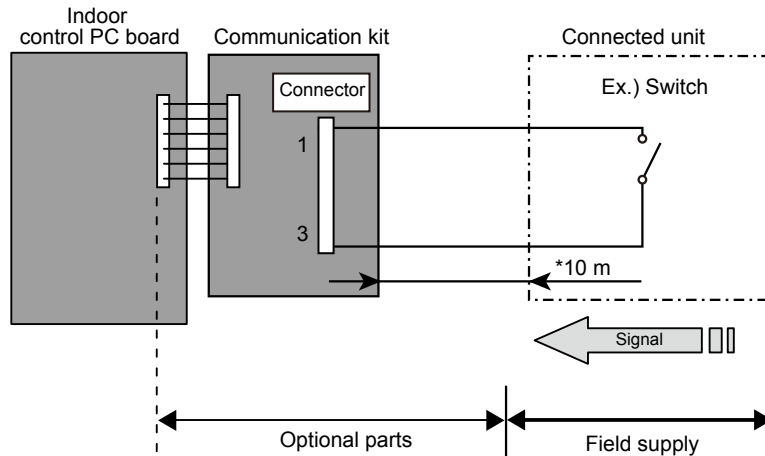

* Make the distance from the PC board to the connected unit within 10m.
Contact capacity : 24VDC or more, 10mA or more.
Please use the non-polar relays and switches.

● When function setting is "Operation/Stop" mode

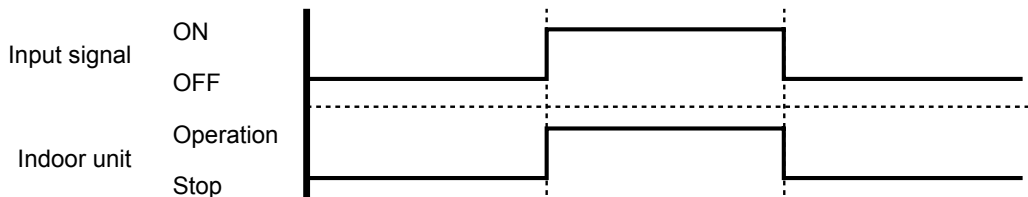

● When function setting is "Forced stop" mode

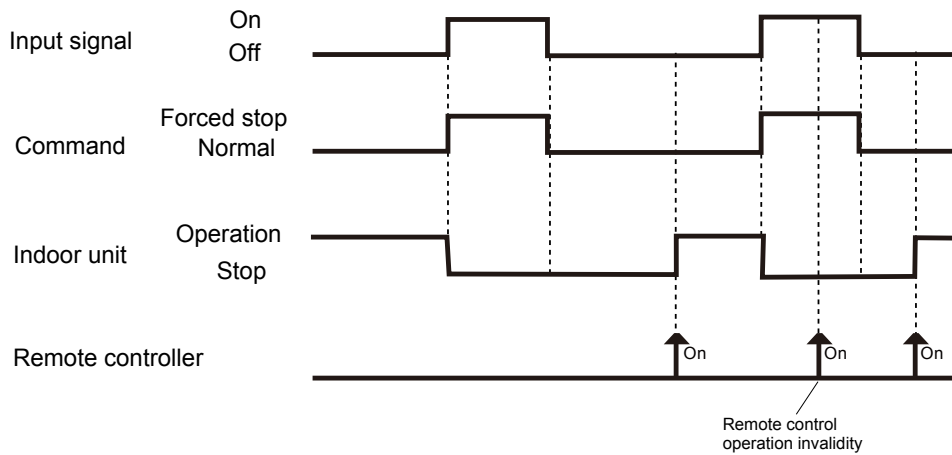

● Parts (Optional)

Parts name	Model name
External connect kit	UTY-XWZX
Communication box kit	UTY-XCBXE (for AS*G07/09/12LE)
	UTY-XCBXZ1 (for AS*G14LE)

*For operating the EXTERNAL function, the Compact wall mounted type requires the communication kit in addition to the wire (UTY-XWZX).

Wire (External input) : UTY-XWZX

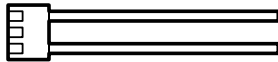

11-2. EXTERNAL OUTPUT

■ OPERATION STATUS OUTPUT

An air conditioner operation status signal can be output.

● Circuit diagram example

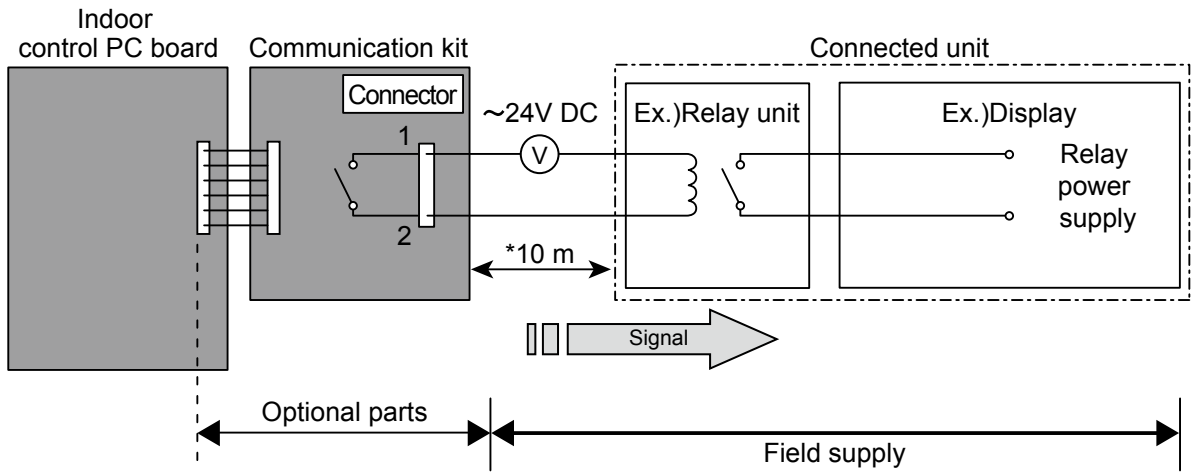

* Make the distance from the PC board to the connected unit within 10m.
Relay spec. : Max.24VDC, 10mA to less than 500mA.

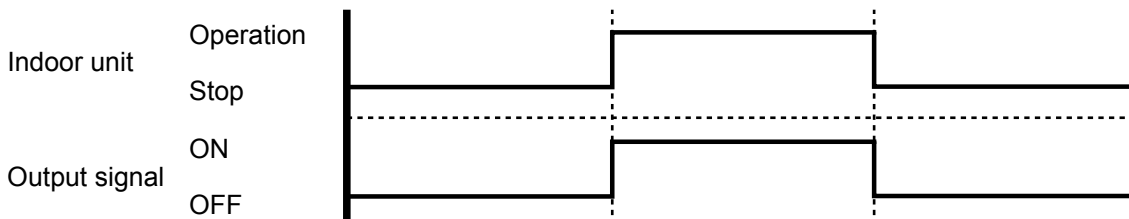

● Parts (Optional)

Parts name	Model name
External connect kit	UTY-XWZX
Communication box kit	UTY-XCBXE (for AS*G07/09/12LE) UTY-XCBXZ1 (for AS*G14LE)

*For operating the EXTERNAL function, the wall mounted type requires the communication kit in addition to the wire (UTY-XWZX).

Wire (External output) : UTY-XWZX

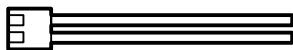

12. FUNCTION SETTING

12-1. INDOOR UNIT (Setting by remote controller)

- The function settings of the control of the indoor unit can be changed by this procedure according to the installation conditions. Incorrect settings can cause the indoor unit malfunction.
- After the power is turned on, perform the "FUNCTION SETTING" according to the installation conditions using the remote controller.
- The settings may be selected between the following two: Function Number or Setting Value.
- Settings will not be changed if invalid numbers or setting values are selected.

■ PREPARATION

- Turn on the power
- * By turning on the power indoor units, so make sure the piping air-tight test and vacuuming have been conducted before turning on the power.
- * Also check again to make sure no wiring mistakes were made before turning on the power.

■ FUNCTION SETTING METHOD (for Wireless remote controller)

Entering the Function Setting Mode

- While pressing the POWERFUL button and SET TEMP. (▲) simultaneously, press the RESET button to enter the function setting mode.

STEP 1

Setting the Remote controller Signal Code

Use the following steps to select the signal code of the remote controller. (Note that the air conditioner cannot receive a signal code if the air conditioner has not been set for the signal code.) The signal codes that are set through this process are applicable only to the signals in the FUNCTION SETTING. For details on how to set the signal codes through the normal process, refer to SELECTING THE REMOTE CONTROLLER SIGNAL CODE.

1. Press the SET TEMP. (▲) (▼) button to change the signal code between $A \rightarrow b \rightarrow c \rightarrow d$. Match the code on the display to the air conditioner signal code. (initially set to A)
(If the signal code does not need to be selected, press the 10°C Heat button and proceed to STEP 2.)
2. Press the MODE button and check that the indoor unit can receive signals at the displayed signal code.
3. Press the 10°C Heat button to accept the signal code, and proceed to STEP 2.

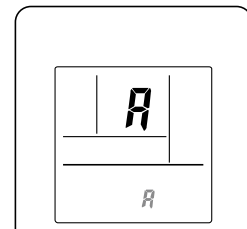

The air conditioner signal code is set to A prior to shipment.
Contact your retailer to change the signal code.

The remote controller resets to signal code A when the batteries in the remote controller are replaced. If you use a signal code other than signal code A, reset the signal code after replacing the batteries.
If you do not know the air conditioner signal code setting, try each of the signal codes ($A \rightarrow b \rightarrow c \rightarrow d$) until you find the code which operates the air conditioner.

STEP 2

Selecting the Function Number and Setting Value

1. Press the SET TEMP. (▲) (▼) buttons to select the function number.
(Press the 10°C Heat button to switch between the left and right digits.)
2. Press the POWERFUL button to proceed to setting the value.
Press the POWERFUL button again to return to the function number selection.)
3. Press the SET TEMP. (▲) (▼) buttons to select the setting value.
(Press the 10°C Heat button to switch between the left and right digits.)
4. Press the MODE button, and START/STOP button, in the order listed to confirm the settings.
5. Press the RESET button to cancel the function setting mode.
6. After completing the FUNCTION SETTING, be sure to turn off the power and turn it on again.

Function number

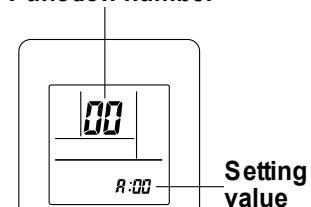

⚠ CAUTION

After turning off the power, wait 10 seconds or more before turning on it again.
The FUNCTION SETTING doesn't become effective if it doesn't do so.

FUNCTION DETAILS

	Functions	Compact wall mounted
1)	Filter sign	●
2)	Cooler room temperature correction	●
3)	Heater room temperature correction	●
4)	Auto restart	●
5)	Indoor room temperature sensor switching function	●
6)	Remote controller signal code	●
7)	External input control	●

1) Filter sign

The indoor unit has a sign to inform the user that it is time to clean the filter. Select the time setting for the filter sign display interval in the table below according to the amount of dust or debris in the room. If you do not wish the filter sign to be displayed, select the setting value for "No indication".

(◆... Factory setting)

Setting description	Function number	Setting value
Standard	11	00
Long interval		01
Short interval		02
No indication		03

The filter sign interval time is different according to Indoor unit type as follows.

Setting description	Compact Wall Mounted
Standard	400 hours
Long interval	1000 hours
Short interval	200 hours

2) Cooler room temperature correction

Depending on the installed environment, the room temperature sensor may require a correction.

The settings may be selected as shown in the table below.

(◆... Factory setting)

Setting description	Function number	Setting value
Standard	30	00
Slightly lower control		01
Lower control		02
Warmer control		03

3) Heater room temperature correction

Depending on the installed environment, the room temperature sensor may require a correction.

The settings may be changed as shown in the table below.

(◆... Factory setting)

Setting description	Function number	Setting value
Standard	31	00
Lower control		01
Slightly warmer control		02
Warmer control		03

4) Auto restart

Enable or disable automatic system restart after a power outage.

(◆... Factory setting)

Setting description	Function number	Setting value
◆ Yes	40	00
No		01

*Auto restart is an emergency function such as for power failure etc.
Do not start and stop the indoor unit by this function in normal operation.
Be sure to operate by the control unit, or external input device.

5) Indoor room temperature sensor switching function

(Only for Wired remote controller)

The following settings are needed when use the control by Wired remote controller temperature sensor.

(◆... Factory setting)

Setting description	Function number	Setting value
◆ No	42	00
Yes		01

*If setting value is "00" :
Room temperature is controlled by the indoor unit temperature sensor.

*If setting value is "01" :
Room temperature is controlled by either indoor unit temperature sensor or remote controller unit sensor.

6) Remote controller signal code

Change the indoor unit Signal Code, depending on the remote controllers.

(◆... Factory setting)

Setting description	Function number	Setting value
◆ A	44	00
B		01
C		02
D		03

7) External input control

"Operation/Stop" mode or "Forced stop" mode can be selected.

(◆... Factory setting)

Setting description	Function number	Setting value
◆ Operation/Stop mode	46	00
(Setting forbidden)		01
Forced stop mode		02

■ REMOTE CONTROLLER SIGNAL CODE SETTING

Use the following steps to select the signal code of the remote controller.

(Note that the air conditioner cannot receive a signal code if the air conditioner has not been set for the signal code.)

1. Press the START/STOP button until only the clock is displayed on the remote controller display.
2. Press the MODE button for at least five seconds to display the current signal code (initially set to **A**).
3. Press the SET TEMP. (**▲**) (**▼**) button to change the signal code between **A** → **b** → **c** → **d**.
Match the code on the display to the air conditioner signal code.
4. Press the MODE button again to return to the clock display. The signal code will be changed.

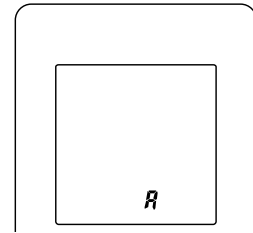





If no buttons are pressed within 30 seconds after the signal code is displayed, the system returns to the original clock display. In this case, start again from step 1.

The air conditioner signal code is set to A prior to shipment.
Contact your retailer to change the signal code.

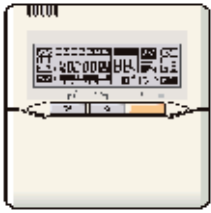
The remote controller resets to signal code A when the batteries in the remote controller are replaced. If you use a signal code other than signal code A, reset the signal code after replacing the batteries. If you do not know the air conditioner signal code setting, try each of the signal codes (**A** → **b** → **c** → **d**) until you find the code which operates the air conditioner.

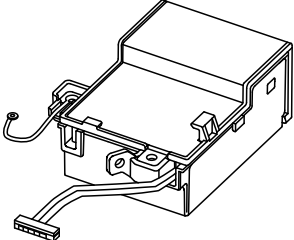
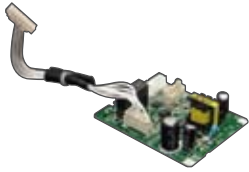
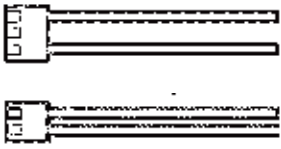
13. OPTIONAL PARTS

Exterior	Parts name	Model No.	Summary
	Wired remote controller	UTY-RNNYM	Unit control is performed by wired remote controller. *Optional communication kit is necessary for the installation.
	Simple remote controller	UTY-RSNYM	Unit control is performed by simple remote controller. *Optional communication kit is necessary for the installation.
	Communication box kit	UTY-XCBXE	Use to connect with optional devices and air conditioner PC board. (for AS*G07/09/12LE)
	Communication kit	UTY-XCBXZ1	Use to connect with optional devices and air conditioner PC board. (for AS*G14LE)
	External connect kit	UTY-XWZX	Required when external device is connected. *Optional communication kit is necessary for the installation.
	Apple-catechin filter	UTR-FA16	Fine dust, invisible mold spores, and harmful microorganisms are absorbed onto the filter by static electricity, and further growth is inhibited and deactivated by the polyphenol ingredient extracted from apples.
	Ion deodorisation filter	UTR-FA16-2	The filter deodorizes by powerfully decomposing absorbed odors using the oxidizing and reducing effects of ions generated by the ultra fine-particle ceramic.

2. OUTDOOR UNIT

SINGLE TYPE :

AO*G07LEC

AO*G09LEC

AO*G12LEC

AO*G14LEC

CONTENTS

2. OUTDOOR UNIT

1. SPECIFICATIONS.....	02 - 01
2. DIMENSIONS	02 - 02
3. REFRIGERANT CIRCUIT	02 - 04
4. WIRING DIAGRAMS.....	02 - 05
5. CAPACITY COMPENSATION RATE FOR PIPE LENGTH AND HEIGHT DIFFERENCE	02 - 07
6. ADDITIONAL CHARGE CALCULATION.....	02 - 10
7. AIR FLOW.....	02 - 11
8. OPERATION NOISE.....	02 - 13
8-1. NOISE LEVEL CURVE	02 - 13
8-2. SOUND LEVEL CHECK POINT	02 - 15
9. ELECTRIC CHARACTERISTICS.....	02 - 16
10. SAFETY DEVICES	02 - 17

1. SPECIFICATIONS

Type			INVERTER HEAT PUMP				
Model name			AO*G07LEC	AO*G09LEC	AO*G12LEC	AO*G14LEC	
Power source			230V~ 50Hz				
Available voltage range			198-264V ~ 50Hz				
Starting current			A	3.5	3.8	4.7	6.0
Fan	Airflow rate	Cooling	m ³ /h	1,720		1,830	1,800
		Heating		1,510		1,600	1,660
	Type*Q'ty	Propeller fan*1					
Motor output		W	40				
Sound pressure level		Cooling	dB(A)	45		50	49
		Heating		45		50	50
Heat exchanger type		Dimensions(H×W×D)	mm	650 × 504 × 18.2		642 × 504 × 36.4	896 × 504 × 36.4
		Fin pitch		1.3		1.4	1.3
		Rows×Stages	1 × 24		2 × 24		
		Pipe type	Copper				
		Fin Type	Aluminium				
Compressor	Type*Q'ty	Rotary*1					
	Motor output	W	500		750		
Refrigerant		Type	R410A				
		Charge	g	650	800	1050	
Refrigerant oil		Type	POE(VG74)				
Enclosure		Material	Steel				
		Colour	Beige Approximate colour of MUNSELL 10YR7.5/1.0				
Dimensions (H×W×D)	Net		mm	540 × 660 × 290		540 × 790 × 290	
	Gross		mm	611 × 797 × 401		648 × 938 × 400	
Weight	Net		kg (lbs.)	23(51)		34(75)	
	Gross			26(57)		38(84)	
Connention pipe	Size	Liquid	mm	Ø6.35 (Ø1/4 in.)			
		Gas		Ø9.52 (Ø3/8in.)		Ø12.7 (Ø1/2in.)	
	Method		Flare				
Pre-charge length		m	15				
Max.length			20				
Max.height difference			15				
Operation range		Cooling	°C	-10 to 43			
		Heating		-15 to 24			

Note :

Specifications are based on the following conditions.

Cooling : Indoor temperature of 27 °CDB / 19 °CWB.and outdoor temperature of 35 °CDB/24 °CWB.

Heating : Indoor temperature of 20 °CDB / 15 °CWB.and outdoor temperature of 7 °CDB/6 °CWB.

Pipe length : 5 m, Height difference : 0 m.(Outdoor unit - Indoor unit)

The maximum current is the maximum value when the operated within the operation range(temperature).

OUTDOOR UNIT
AO*G07-14LE

OUTDOOR UNIT
AO*G07-14LE

2. DIMENSIONS

■ MODEL: AO*G07LE, AO*G09LE, AO*G12LE

(Unit : mm)

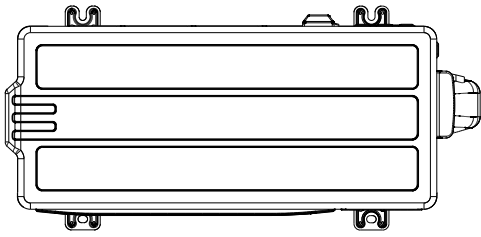

Top view

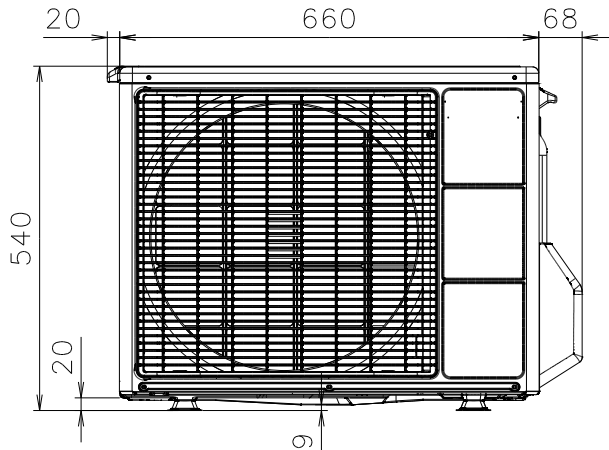

Front view

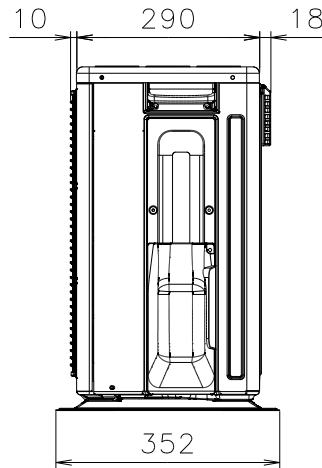

Side view

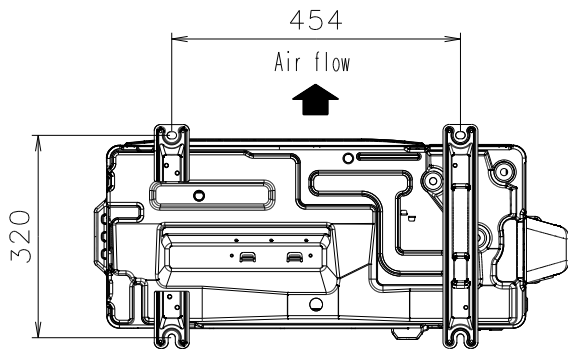

Bottom view

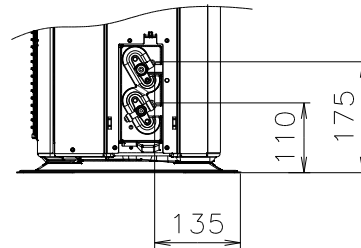

■ INSTALLATION PLACE

When there are obstacles at the back or front sides.

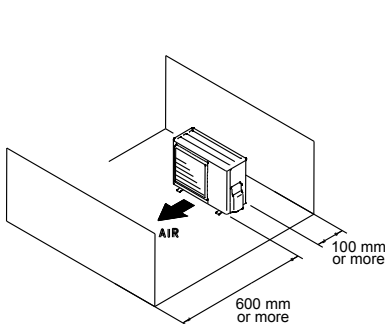

When there are obstacles at the back, side(s), and top.

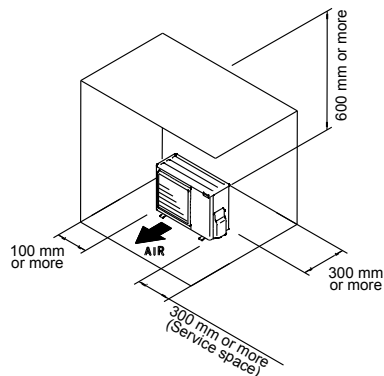

When there are obstacles at the back, side with the installation of more than one unit.

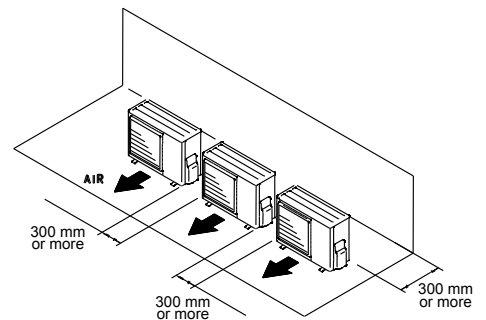

MODEL: AO*G14LE

(Unit : mm)

OUTDOOR UNIT
AO*G07-14LE

OUTDOOR UNIT
AO*G07-14LE

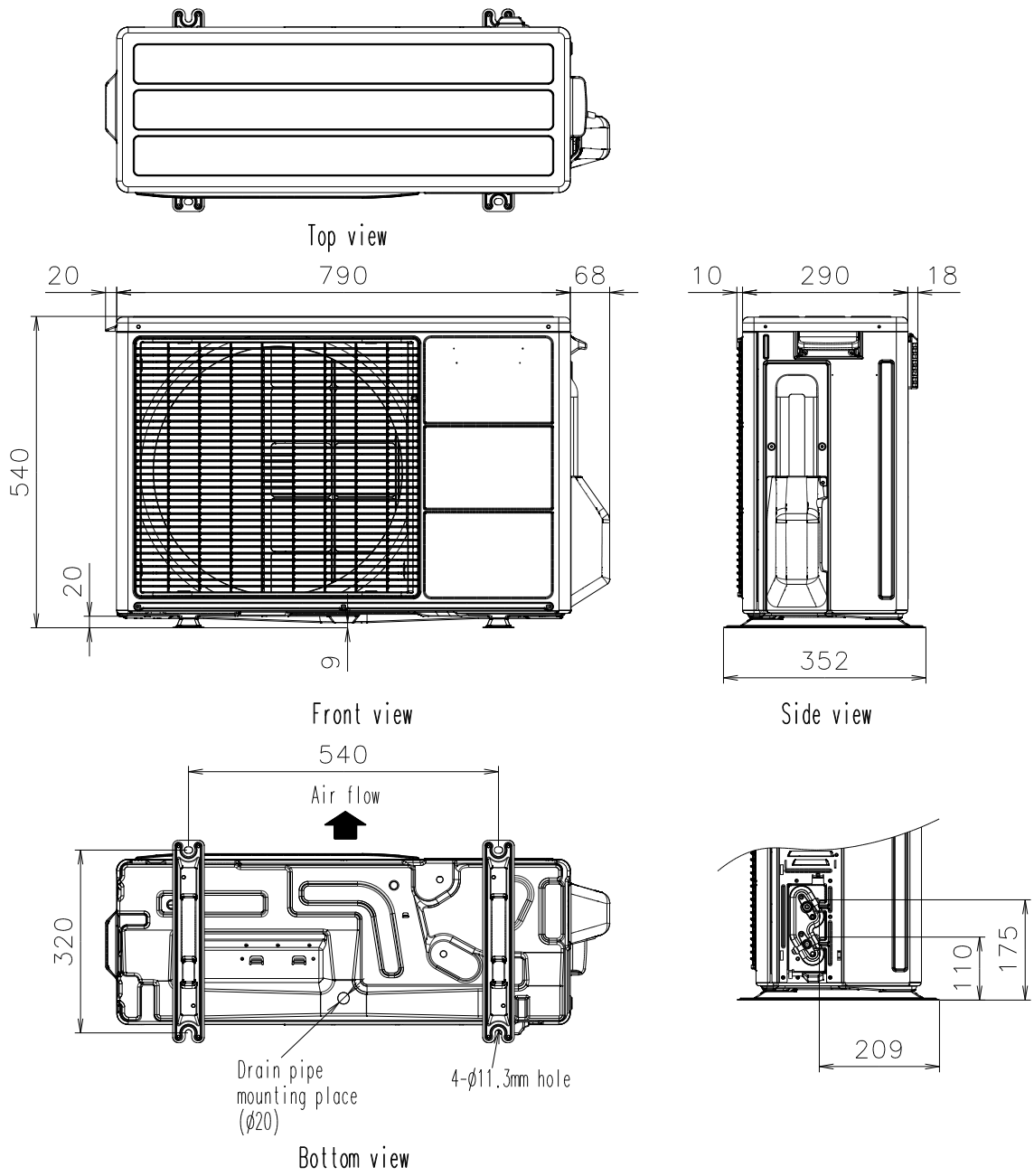

INSTALLATION PLACE

When there are obstacles at the back or front sides.

When there are obstacles at the back, side(s), and top.

When there are obstacles at the back, side with the installation of more than one unit.

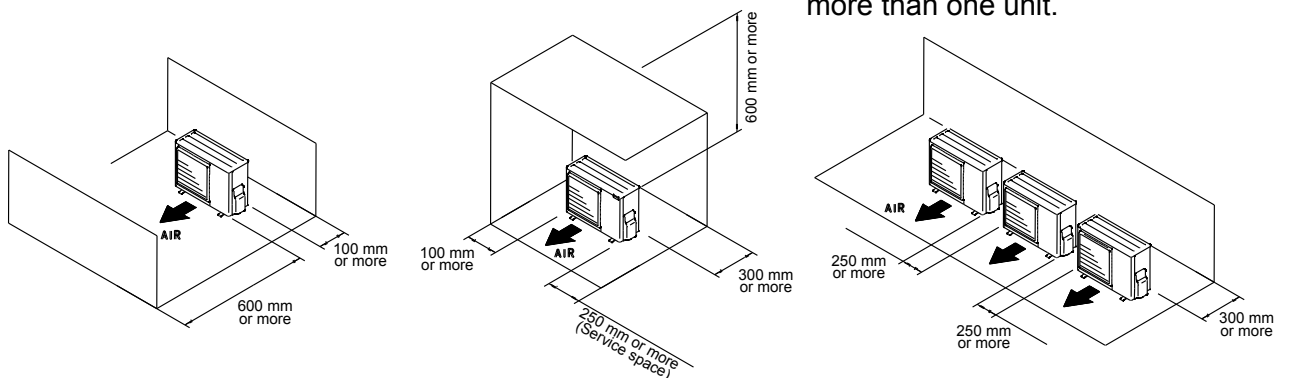

3. REFRIGERANT CIRCUIT

■ MODEL: AO*G07LE, AO*G09LE, AO*G12LE, AO*G14LE

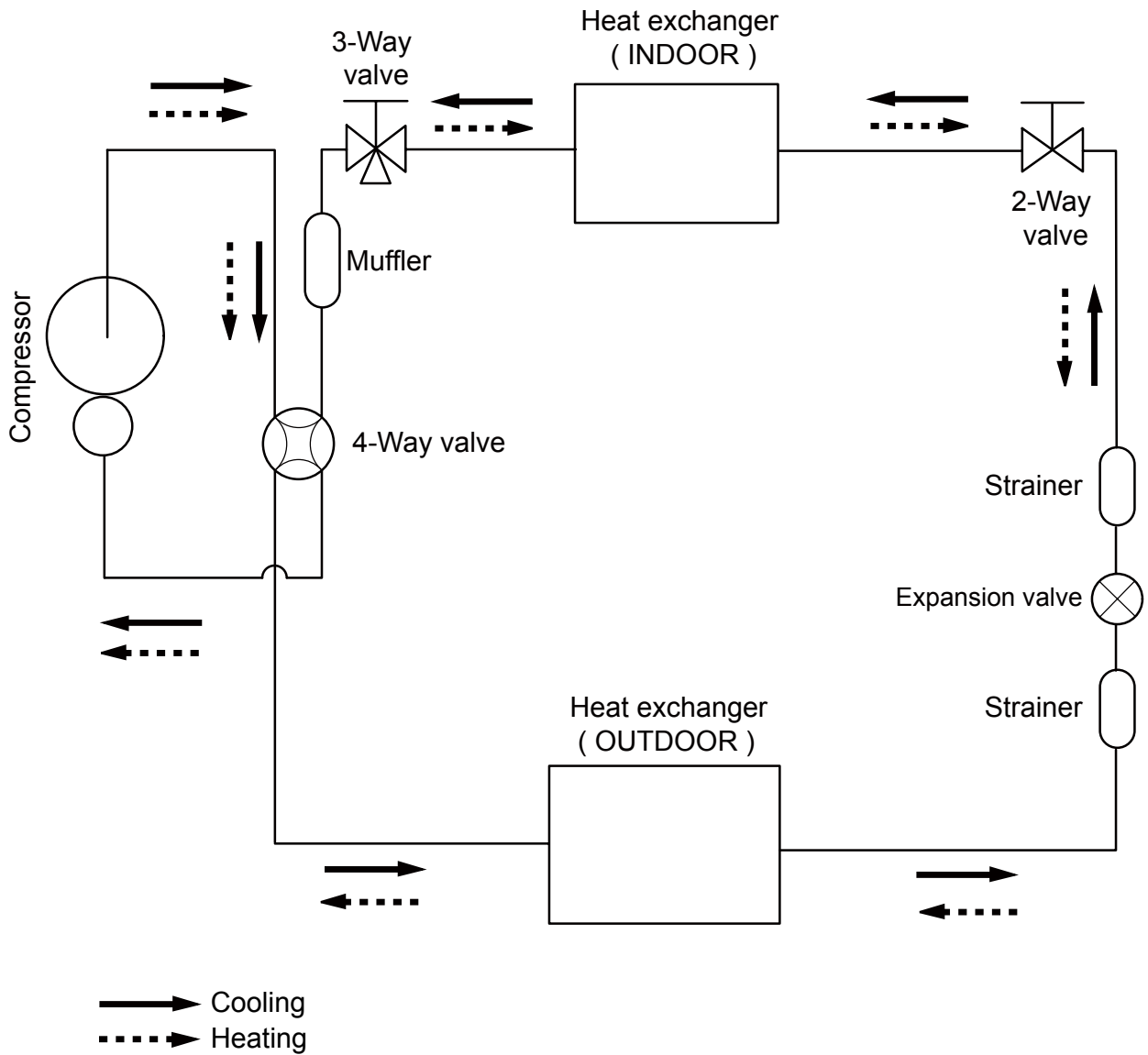

Refrigerant pipe diameter
 Liquid : 1/4" (6.35 mm)
 Gas : 3/8" (9.52 mm) :07/09/12LE
 1/2" (12.7 mm) :14LE

OUTDOOR UNIT
AO*G07-14LE

OUTDOOR UNIT
AO*G07-14LE

4. WIRING DIAGRAMS

■ MODEL: AO*G07LE, AO*G09LE

OUTDOOR UNIT
AO*G07-14LE

OUTDOOR UNIT
AO*G07-14LE

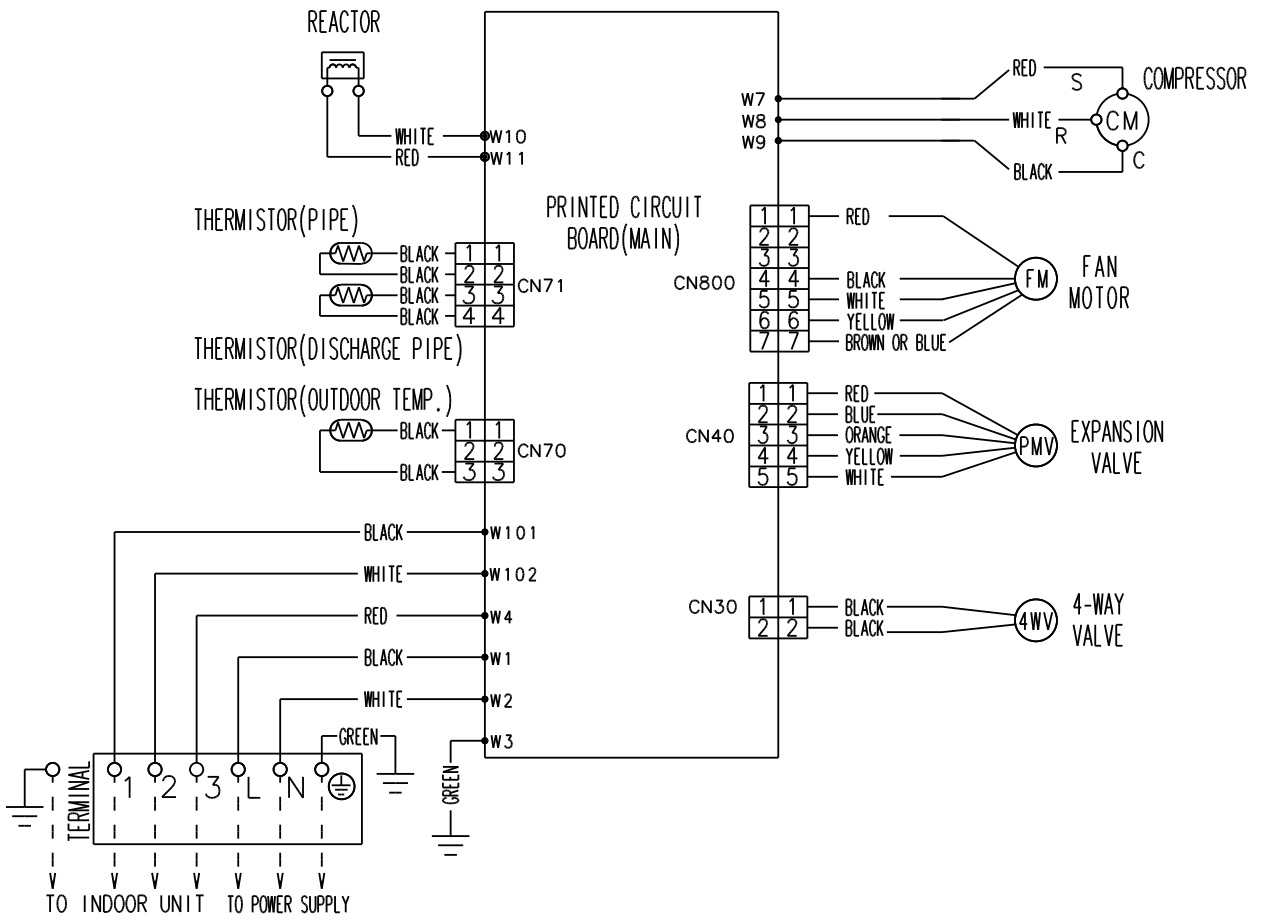

MODEL: AO*G12LE, AO*G14LE

OUTDOOR UNIT
AO*G07-14LE

OUTDOOR UNIT
AO*G07-14LE

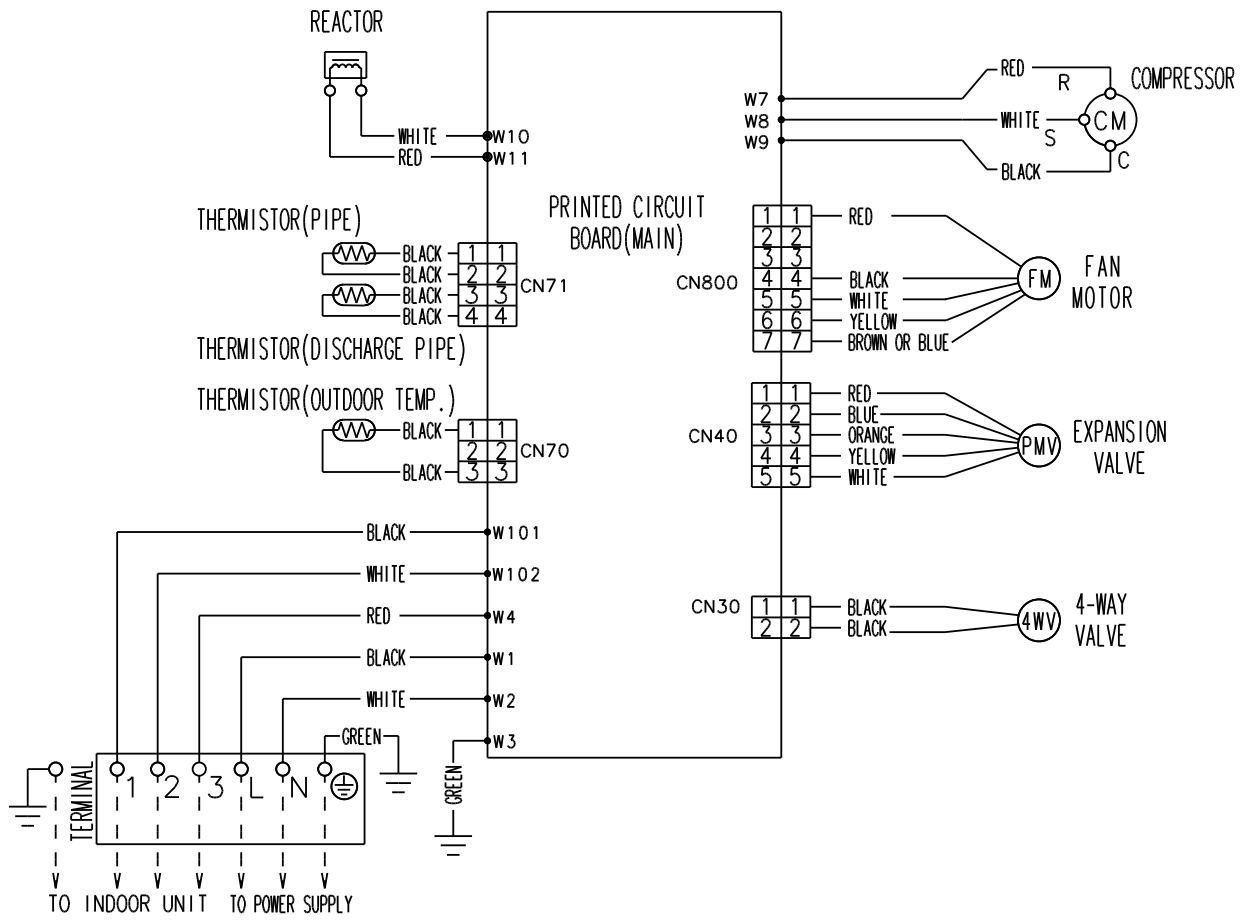

5. CAPACITY COMPENSATION RATE FOR PIPE LENGTH AND HEIGHT DIFFERENCE

■ MODEL: AO*G07LE, AO*G09LE

OUTDOOR UNIT
AO*G07-14LE

OUTDOOR UNIT
AO*G07-14LE

COOLING			Pipe length (m)				
			5	7.5	10	15	20
Height difference H (m)	*1 Indoor unit is upper than outdoor unit.	15	-	-	-	0.872	0.910
		10	-	-	0.961	0.886	0.925
		7.5	-	0.979	0.965	0.890	0.929
		5	0.992	0.983	0.969	0.893	0.933
	0	1.000	0.991	0.976	0.901	0.940	
	*2 Indoor unit is under than outdoor unit	-5	1.000	0.991	0.976	0.901	0.940
		-7.5	-	0.991	0.976	0.901	0.940
		-10	-	-	0.976	0.901	0.940
		-15	-	-	-	0.901	0.940

HEATING			Pipe length (m)				
			5	7.5	10	15	20
Height difference H (m)	*1 Indoor unit is upper than outdoor unit.	15	-	-	-	0.832	0.822
		10	-	-	0.917	0.832	0.822
		7.5	-	0.961	0.917	0.832	0.822
		5	1.000	0.961	0.917	0.832	0.822
	0	1.000	0.961	0.917	0.832	0.822	
	*2 Indoor unit is under than outdoor unit	-5	0.995	0.956	0.912	0.828	0.818
		-7.5	-	0.954	0.910	0.826	0.816
		-10	-	-	0.908	0.824	0.814
		-15	-	-	-	0.815	0.805

Height difference H

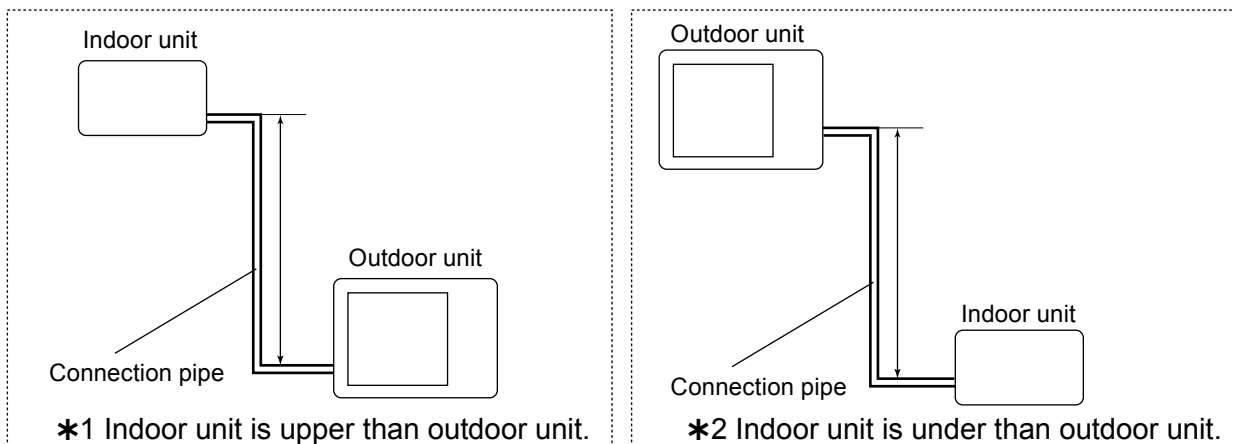

MODEL: AO*G12LE

OUTDOOR UNIT
AO*G07-14LE

OUTDOOR UNIT
AO*G07-14LE

COOLING			Pipe length (m)				
			5	7.5	10	15	20
Height difference H (m)	*1 Indoor unit is upper than outdoor unit.	15	-	-	-	0.858	0.868
		10	-	-	0.929	0.872	0.882
		7.5	-	0.960	0.933	0.876	0.885
		5	0.992	0.964	0.937	0.879	0.889
	0	1.000	0.972	0.944	0.887	0.896	
	*2 Indoor unit is under than outdoor unit	-5	1.000	0.972	0.944	0.887	0.896
		-7.5	-	0.972	0.944	0.887	0.896
		-10	-	-	0.944	0.887	0.896
		-15	-	-	-	0.887	0.896

HEATING			Pipe length (m)				
			5	7.5	10	15	20
Height difference H (m)	*1 Indoor unit is upper than outdoor unit.	15	-	-	-	0.896	0.879
		10	-	-	0.968	0.890	0.879
		7.5	-	0.994	0.968	0.896	0.879
		5	1.000	0.994	0.968	0.896	0.879
	0	1.000	0.994	0.968	0.896	0.879	
	*2 Indoor unit is under than outdoor unit	-5	0.995	0.989	0.963	0.891	0.875
		-7.5	-	0.987	0.961	0.889	0.873
		-10	-	-	0.959	0.887	0.871
		-15	-	-	-	0.878	0.862

Height difference H

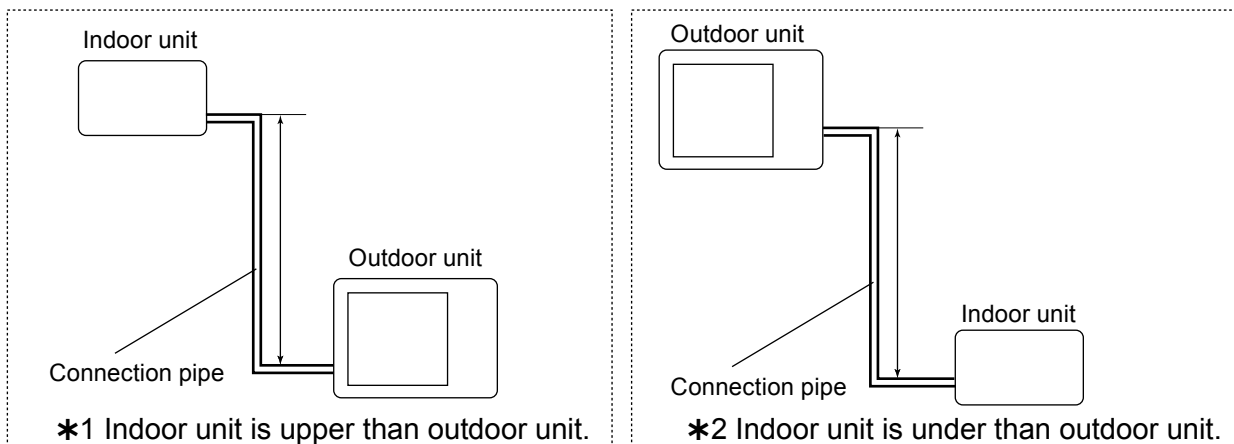

MODEL: AO*G14LE

OUTDOOR UNIT
AO*G07-14LE

OUTDOOR UNIT
AO*G07-14LE

COOLING			Pipe length (m)				
			5	7.5	10	15	20
Height difference H (m)	*1 Indoor unit is upper than outdoor unit.	15	-	-	-	0.893	0.909
		10	-	-	0.955	0.908	0.924
		7.5	-	0.975	0.959	0.912	0.928
		5	0.992	0.979	0.963	0.916	0.931
	0	1.000	0.987	0.970	0.923	0.939	
	*2 Indoor unit is under than outdoor unit	-5	1.000	0.987	0.970	0.923	0.939
		-7.5	-	0.987	0.970	0.923	0.939
		-10	-	-	0.970	0.923	0.939
		-15	-	-	-	0.923	0.939

HEATING			Pipe length (m)				
			5	7.5	10	15	20
Height difference H (m)	*1 Indoor unit is upper than outdoor unit.	15	-	-	-	0.956	0.938
		10	-	-	1.004	0.956	0.938
		7.5	-	1.013	1.004	0.956	0.938
		5	1.000	1.013	1.004	0.956	0.938
	0	1.000	1.013	1.004	0.956	0.938	
	*2 Indoor unit is under than outdoor unit	-5	0.995	1.008	0.999	0.951	0.933
		-7.5	-	1.005	0.997	0.948	0.931
		-10	-	-	0.994	0.946	0.929
		-15	-	-	-	0.937	0.919

Height difference H

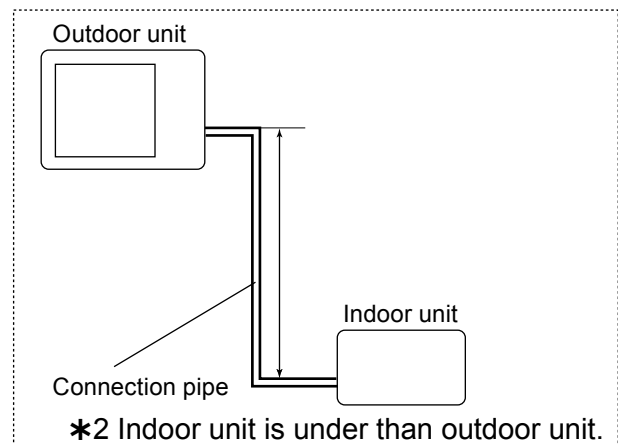
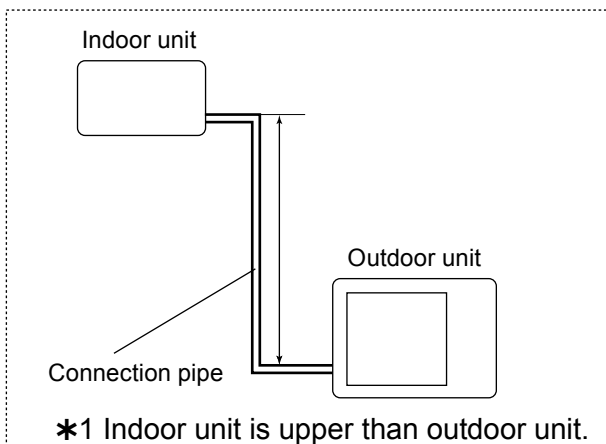

6. ADDITIONAL CHARGE CALCULATION

■ MODEL: AO*G07LE, AO*G09LE

Refrigerant type		R410A
Refrigerant amount	g	650

● Refrigerant charge

Total pipe length	m	15 or less	20 (MAX)	20g/m
Additional charge	g	0	100	

■ MODEL: AO*G12LE

Refrigerant type		R410A
Refrigerant amount	g	800

● Refrigerant charge

Total pipe length	m	15 or less	20 (MAX)	20g/m
Additional charge	g	0	100	

■ MODEL: AO*G14LE

Refrigerant type		R410A
Refrigerant amount	g	1050

● Refrigerant charge

Total pipe length	m	15 or less	20 (MAX)	20g/m
Additional charge	g	0	100	

7. AIR FLOW

■ MODEL: AO*G07LE, AO*G09LE

● Cooling

Number of rotations (r.p.m.)	Air flow	
	730	1720
476		l/s
1011		CFM

● Heating

Number of rotations (r.p.m.)	Air flow	
	650	1510
418		l/s
888		CFM

■ MODEL: AO*G12LE

● Cooling

Number of rotations (r.p.m.)	Air flow	
	860	1830
507		l/s
1076		CFM

● Heating

Number of rotations (r.p.m.)	Air flow	
	760	1600
443		l/s
941		CFM

■ **MODEL: AO*G14LE**

● **Cooling**

Number of rotations (r.p.m.)	Air flow	
	800	1800
499		l/s
1058		CFM

● **Heating**

Number of rotations (r.p.m.)	Air flow	
	750	1660
460		l/s
976		CFM

8. OPERATION NOISE

8-1. NOISE LEVEL CURVE

MODEL: AO*G07LE

● Cooling

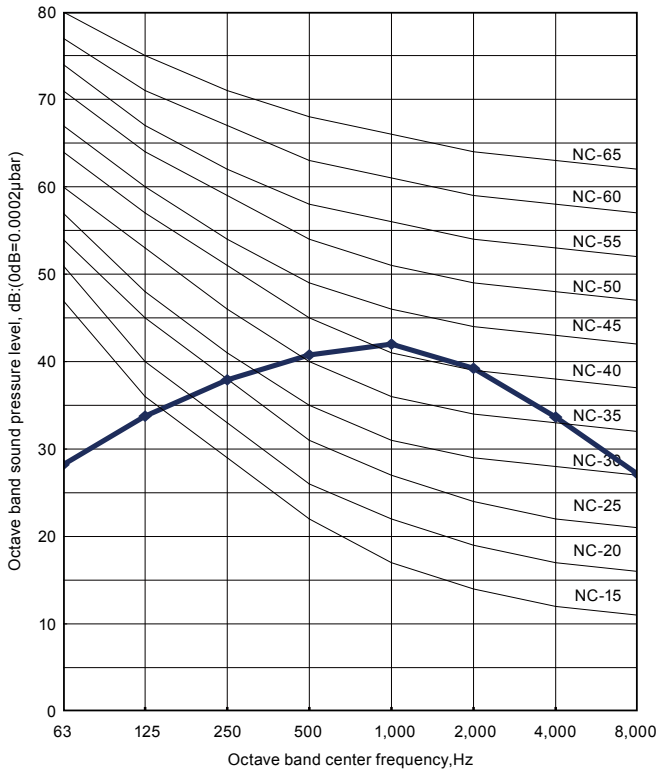

● Heating

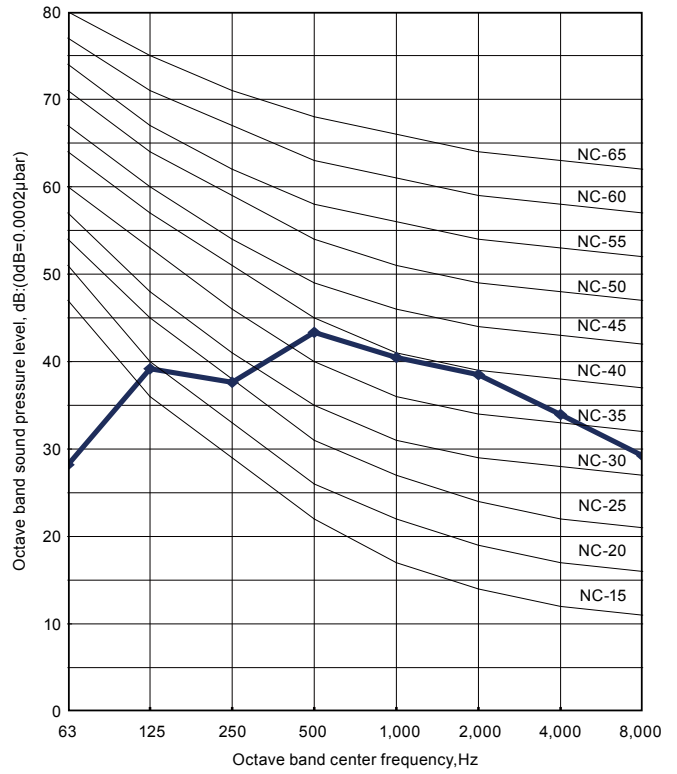

MODEL: AO*G09LE

● Cooling

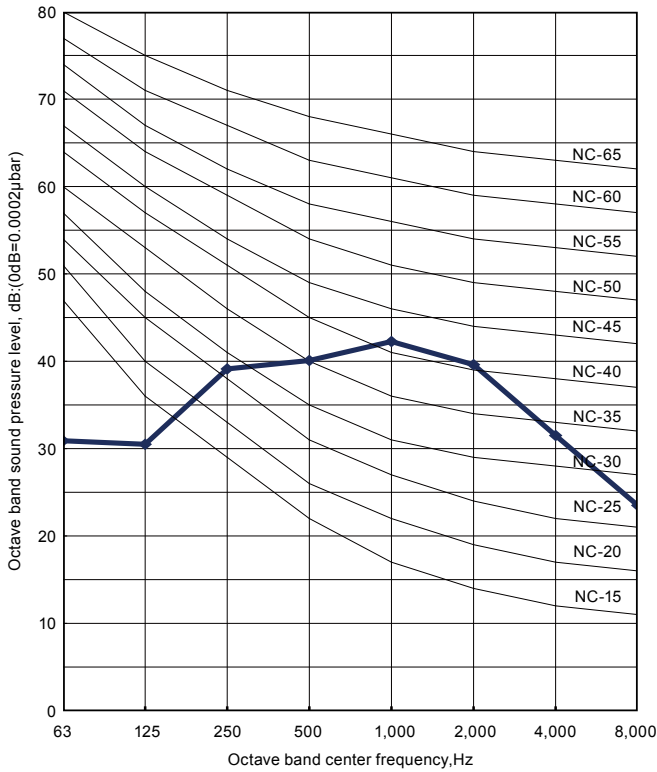

● Heating

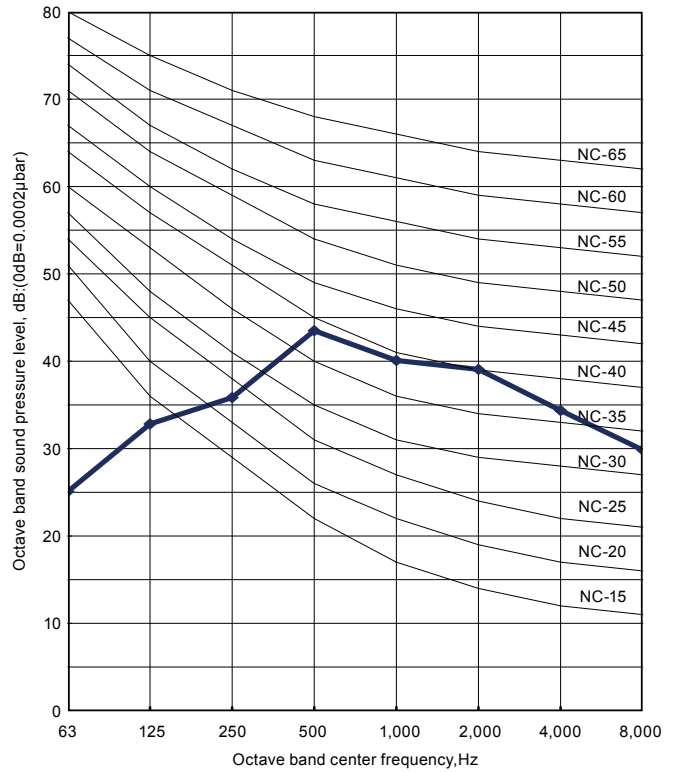

OUTDOOR UNIT
AO*G07-14LE

OUTDOOR UNIT
AO*G07-14LE

MODEL: AO*G12LE

● Cooling

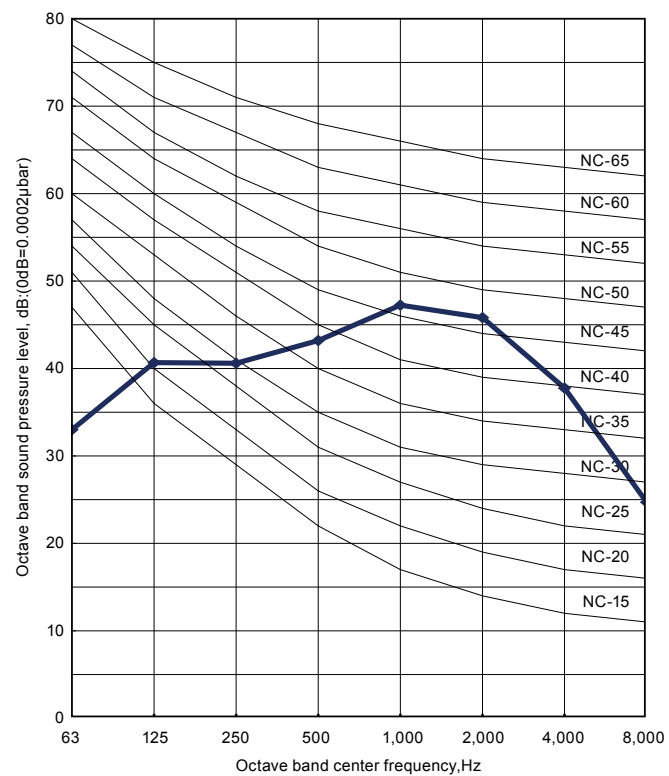

● Heating

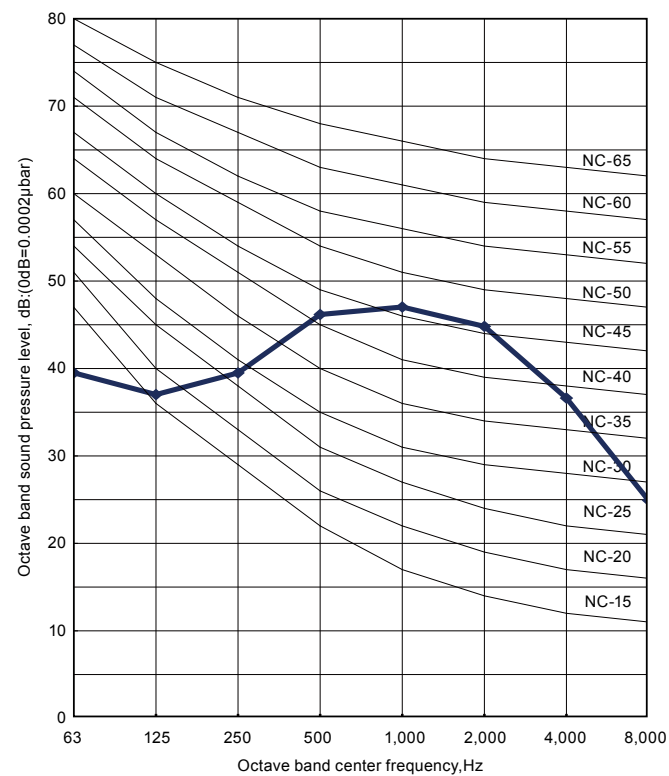

MODEL: AO*G14LE

● Cooling

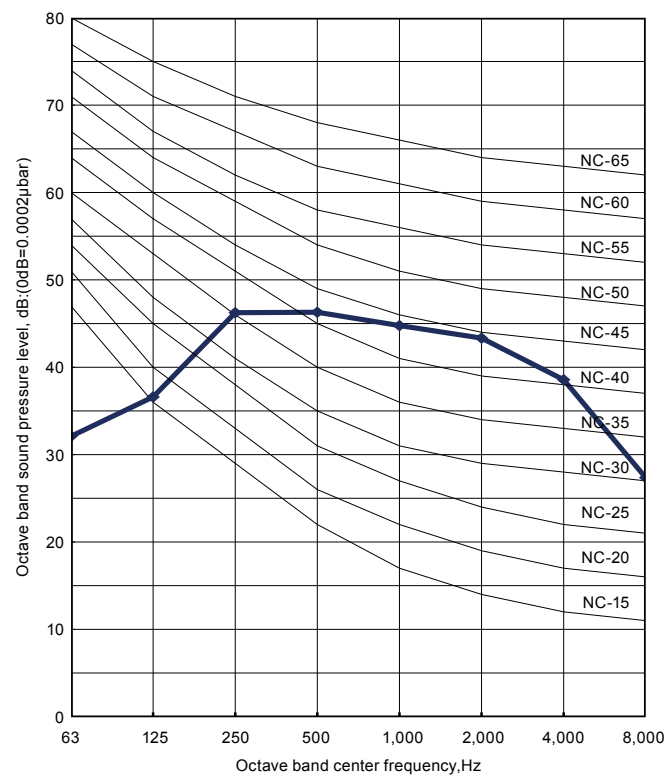

● Heating

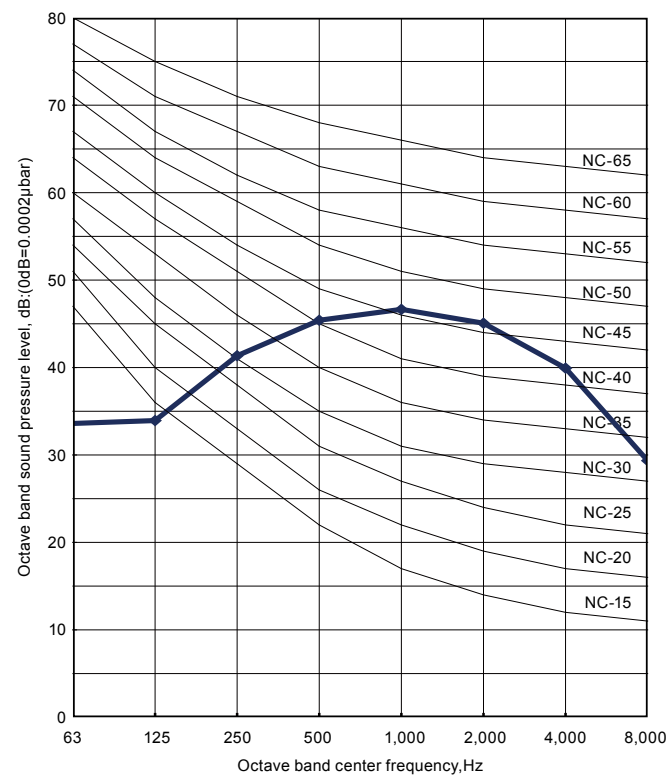

8-2. SOUND LEVEL CHECK POINT

OUTDOOR UNIT
AO*G07-14LE

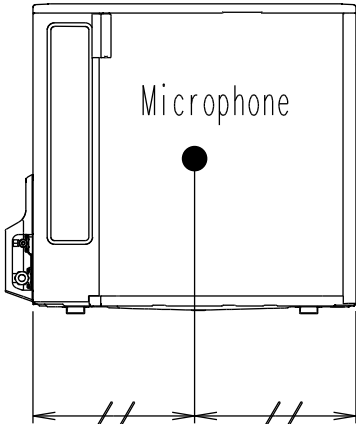
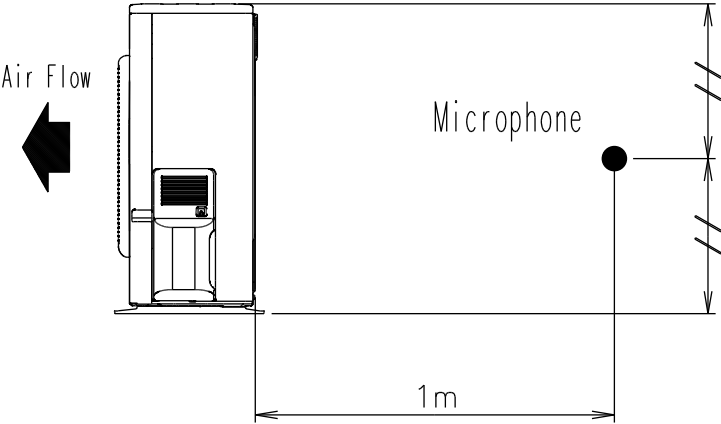

OUTDOOR UNIT
AO*G07-14LE

9. ELECTRIC CHARACTERISTICS

Model name			AO*G07LE	AO*G09LE	AO*G12LE	AO*G14LE
Power supply	Voltage	V	230 ~			
	Frequency	Hz	50			
*1) Max operating current		A	7.5	7.5	9.0	10.5
Starting Current		A	3.5	3.8	4.7	6.0
*2) Wiring Spec.:	Main Fuse (Circuit breaker) Current	A	20			
	Power Cable	mm ²	1.5			
	*3) Limited wiring length :	m	21			

*1) The maximum current is the total current of indoor unit and outdoor unit.

*2) Wiring Spec.:

Selected Sample

(Selected based on Japan Electrotechnical Standard and Codes Committee E0005)

*3) Limited wiring length :

This is the wiring length in case voltage descent is less than 2%.

When the wiring length becomes long, please select the wiring of a more larger diameter.

10. SAFETY DEVICES

	Protection form	Model			
		AO*G07LE	AO*G09LE	AO*G12LE	AO*G14LE
Circuit protection	Current fuse (MAIN PRINTED CIRCUIT BOARD)	20A/250V 5A/250V			
Fan motor protection	Thermal protection program	OFF : 100 ⁺¹⁰ ₋₁₀ °C ON : 95 ⁺¹⁰ ₋₁₀ °C			
High Pressure Protection	Terminal protection program COMPRESSOR TEMP.	OFF:110°C ON:After 7 minutes			

OUTDOOR UNIT
AO*G07-14LE

OUTDOOR UNIT
AO*G07-14LE