

AIR CONDITIONER

Cassette type

DESIGN & TECHNICAL MANUAL

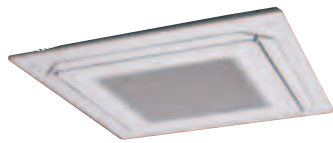

INDOOR

AUXG18LRLB
AUXG24LRLB
AUXG30LRLB
AUXG36LRLB
AUXG45LRLB
AUXG54LRLB

OUTDOOR

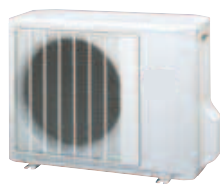

AOYG18LBCA
AOYG24LBCA

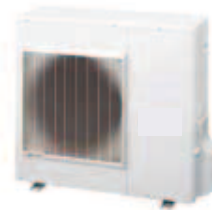

AOYG30LBTA
AOYG36LBTA



AOYG45LBTA
AOYG54LBTA

FUJITSU GENERAL LIMITED

Notices:

- Product specifications and design are subject to change without notice for future improvement.
- For further details, please check with our authorized dealer.

CONTENTS

Part 1. INDOOR UNIT 1

1. Product features	2
1-1. Model lineup	2
1-2. Features	2
2. Wired remote controller	5
2-1. Features	5
2-2. Overview	9
2-3. Specifications	10
2-4. Wiring specifications	10
3. Specifications	11
3-1. Models: AUXG18LRLB and AUXG24LRLB	11
3-2. Models: AUXG30LRLB, AUXG36LRLB, AUXG45LRLB, and AUXG54LRLB	13
4. Dimensions	15
4-1. Models: AUXG18LRLB and AUXG24LRLB	15
4-2. Models: AUXG30LRLB, AUXG36LRLB, AUXG45LRLB, and AUXG54LRLB	17
4-3. Installation space requirement	19
5. Wiring diagram	21
5-1. Models: AUXG18LRLB, AUXG24LRLB, AUXG30LRLB, AUXG36LRLB, AUXG45LRLB, and AUXG54LRLB	21
6. Capacity table	22
6-1. Cooling capacity	22
6-2. Heating capacity	25
7. Fan performance	27
7-1. Air velocity distributions	27
7-2. Airflow	39
7-3. Fresh-air characteristics	45
7-4. Duct connection	46
8. Operation noise (sound pressure)	49
8-1. Noise level curve	49
8-2. Sound level check point	52
9. Safety devices	53
10. External input and output	54
10-1.External input	54
10-2.External output	56
10-3.Combination of external input and output	57
10-4.Details of function	59
11. Function settings	65
11-1.Function settings on indoor unit	65
11-2.Function settings by using remote controller	67
12. Wired remote controller (Touch panel)	74

CONTENTS (continued)

12-1.Remote controller address setting	74
12-2.Remote controller master/slave setting	76
12-3.Memory backup setting	76
13. Optional parts	77
13-1.Controllers	77
13-2.Cassette grille	78
13-3.Others	78

CONTENTS (continued)

Part 2. OUTDOOR UNIT81

1. Specifications	82
1-1. Models: AOYG18LBCA and AOYG24LBCA	82
1-2. Models: AOYG30LBTA and AOYG36LBTA	83
1-3. Models: AOYG45LBTA and AOYG54LBTA	84
2. Dimensions	85
2-1. Models: AOYG18LBCA and AOYG24LBCA	85
2-2. Models: AOYG30LBTA and AOYG36LBTA	86
2-3. Models: AOYG45LBTA and AOYG54LBTA	87
3. Installation space	88
3-1. Models: AOYG18LBCA and AOYG24LBCA	88
3-2. Models: AOYG30LBTA and AOYG36LBTA	91
3-3. Models: AOYG45LBTA and AOYG54LBTA	94
4. Refrigerant circuit	97
4-1. Models: AOYG18LBCA and AOYG24LBCA	97
4-2. Models: AOYG30LBTA and AOYG36LBTA	98
4-3. Models: AOYG45LBTA and AOYG54LBTA	99
5. Wiring diagrams	100
5-1. Models: AOYG18LBCA and AOYG24LBCA	100
5-2. Model: AOYG30LBTA	101
5-3. Model: AOYG36LBTA	102
5-4. Models: AOYG45LBTA and AOYG54LBTA	103
6. Capacity compensation rate for pipe length and height difference	104
6-1. Model: AOYG18LBCA	104
6-2. Model: AOYG24LBCA	105
6-3. Model: AOYG30LBTA	106
6-4. Model: AOYG36LBTA	107
6-5. Model: AOYG45LBTA	108
6-6. Model: AOYG54LBTA	109
7. Additional charge calculation	110
7-1. Models: AOYG18LBCA and AOYG24LBCA	110
7-2. Models: AOYG30LBTA and AOYG36LBTA	110
7-3. Models: AOYG45LBTA and AOYG54LBTA	110
8. Airflow	111
8-1. Model: AOYG18LBCA	111
8-2. Model: AOYG24LBCA	111
8-3. Model: AOYG30LBTA	111
8-4. Model: AOYG36LBTA	112
8-5. Model: AOYG45LBTA	112
8-6. Model: AOYG54LBTA	112
9. Operation noise (sound pressure)	113

CONTENTS (continued)

9-1. Noise level curve	113
9-2. Sound level check point	116
10. Electrical characteristics	117
11. Safety devices	118
12. External input and output (Only for AOYG45LBTA and AOYG54LBTA)	120
12-1.External input	120
12-2.External output	122
13. Function settings (Only for AOYG45LBTA and AOYG54LBTA)	124
13-1.Local setting switch buttons	124
13-2.Local setting procedure	126
14. Optional parts	129

Part 1. INDOOR UNIT

CASSETTE TYPE:

AUXG18LRLB

AUXG24LRLB

AUXG30LRLB

AUXG36LRLB

AUXG45LRLB

AUXG54LRLB

1. Product features

Implemented core technology provides easy-to-use product operations that realize a comfortable space.

1-1. Model lineup

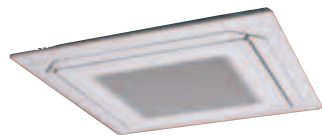

AUXG18LRLB
AUXG24LRLB
AUXG30LRLB
AUXG36LRLB
AUXG45LRLB
AUXG54LRLB



AOYG18LBCA
AOYG24LBCA



AOYG30LBTA
AOYG36LBTA



AOYG45LBTA
AOYG54LBTA

1-2. Features

■ Energy efficiency class

	MODEL			
	AUXG18LRLB	AUXG24LRLB	AUXG30LRLB	AUXG36LRLB
Cooling	A ⁺⁺	A ⁺⁺	A ⁺⁺	A ⁺⁺
Heating	A ⁺	A ⁺	A ⁺	A ⁺

■ Energy saving

- All DC design
- Heat exchange efficiency increased and larger airflow by adoption of new type turbo fan

■ Advancement in comfort

● Quiet operation

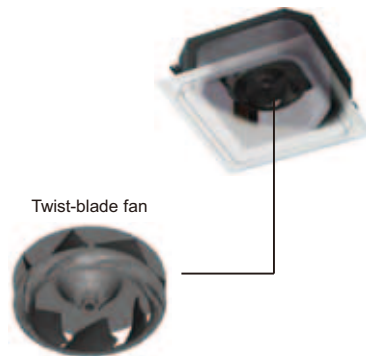

Reduce sound level by decreasing spiral airflow!

● Individual airflow provides free air conditioning

- Individual airflow can be controlled by wired remote controller.
- Individual airflow also can be controlled in any positions.

Case study:

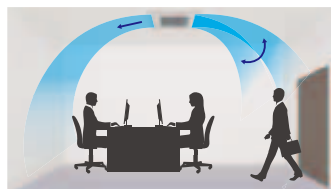

Comfortable air conditioning by draft prevention and swing air blow.

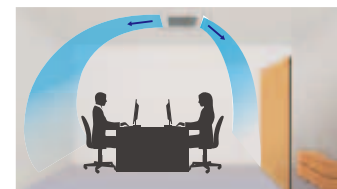

Efficient air conditioning based on the room layout.

● Wide airflow achieved quick air conditioning around all directions

- New wide louver can provide more airflow.
- The louver design distributes airflow at the corner.

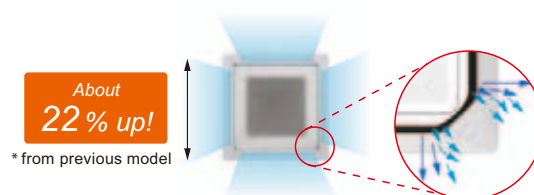

- Uniform temperature air conditioning by airflow

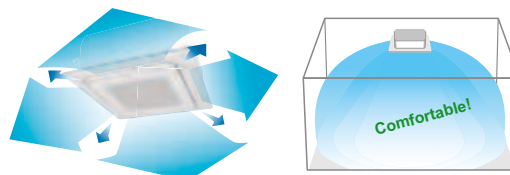

■ Economy operation

Limits the maximum operation current, and the power consumption is cut down and the maximum load is suppressed.

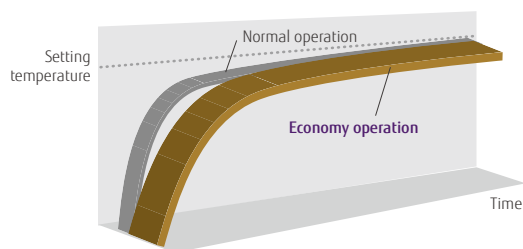

■ Improvement of installation and maintenance

● High lift drain pump

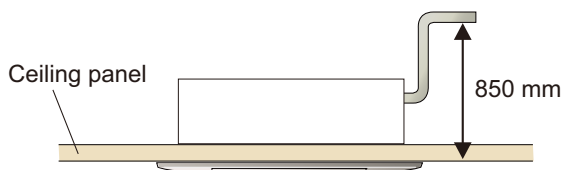

● Easy installation

Easy setting by wired remote controller.

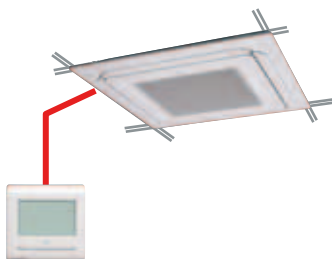

2. Wired remote controller

2-1. Features



- Easy finger touch operation with LCD panel
- Built-in weekly/daily timer (on/off, temperature and mode)
- The backlit LCD enables easy operation in a dark room.
- Room temperature display
- Control up to 16 indoor units
- Corresponds to 12 different languages (English, Chinese, French, German, Spanish, Russian, Polish, Italian, Portuguese, Greek, Turkish, and Dutch)

■ High performance and compact size



■ Accurate and comfortable control

Indoor temperature can be detected accurately by the room temperature sensor built in the wired remote controller.

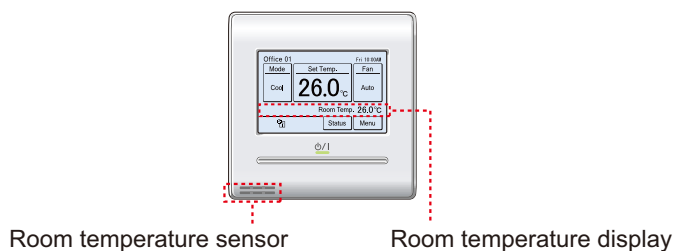

■ Various energy saving control

• Auto-off timer

- The indoor unit automatically turns off after the set time has passed.
- The time interval for which auto-off works can be set.

Example: At interval time hour (17:00 to 24:00) to prevent forgetting to turn off.

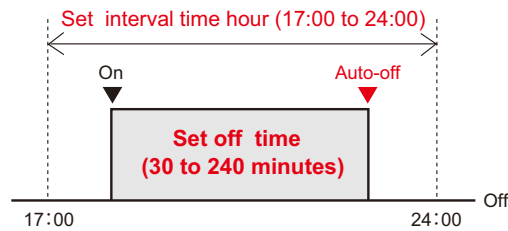

• 2 schedules weekly timer

- 2 schedules such as for the summer and winter can be set.
- 8 setting changeable per day of week (Setting items: on/off, temperature, mode, and time)

Setting example:

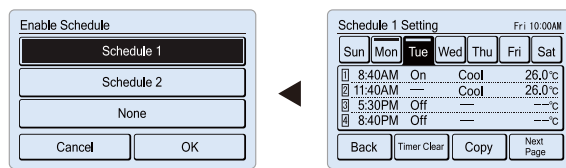

Schedule 1 (Summer schedule)

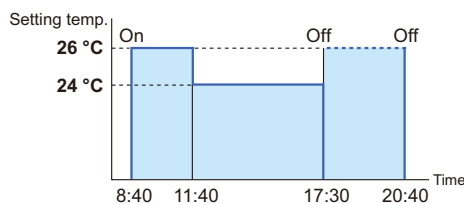

Schedule 2 (Winter schedule)

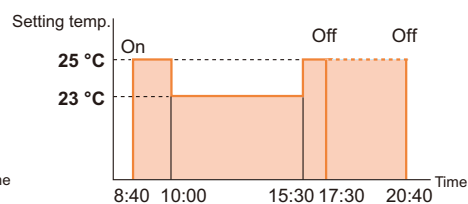

• Set temperature auto return

- The setting temperature automatically returns to the previous setting temperature.
- The time range in which the set temperature can be changed is 10 to 120 minutes.

Cooling operation

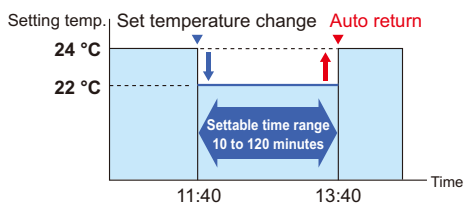

Heating operation

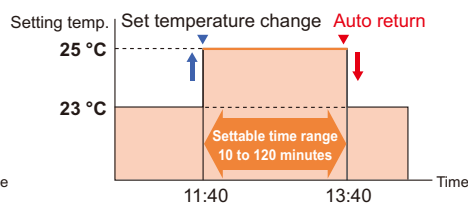

• Set temperature upper and lower limit setting

The set temperature range can be set for each operation mode (COOL, HEAT, and AUTO).

During cooling

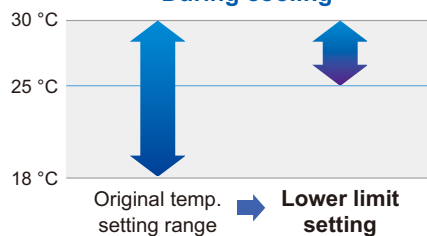

During heating

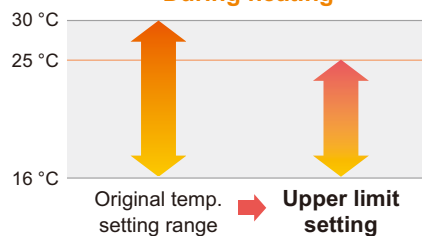

■ Various convenient functions

- Displays setting status and limitations

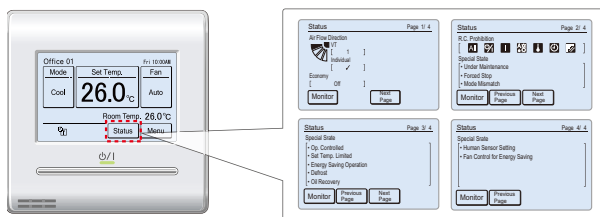

The remote controller settings can be easily checked.

- Summer time display

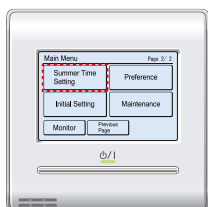

Can be set easily from "Menu" screen.

- Child safety lock

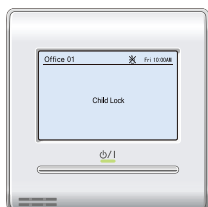

Lock/unlock procedure: While touching the blank field on "Monitor" screen, push the on/off button for 4 seconds.

■ Simplified installation

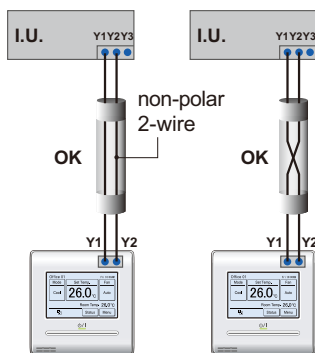

Use of non-polar 2-wire type

Faulty wiring can be prevented by using non-polar 2-wire.

■ Easy maintenance

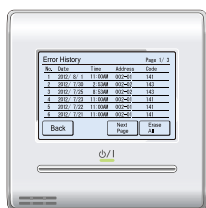

Error history display

- Errors occur on the indoor unit or the remote controller are saved as a history.
- Maximum of 32-error incidents can be saved.

■ Backlit LCD

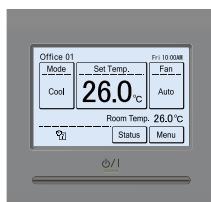

- The backlit LCD enables easy operation in a dark room.
- Backlighting time can be selected from 30 or 60 seconds.
- The backlight is lit while the buttons are operated, and goes off 30 or 60 seconds after the operation stops.

■ System diagram

1 remote controller

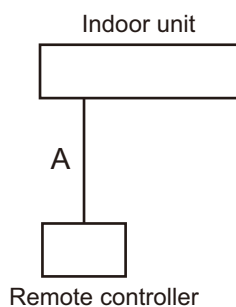

2 remote controllers

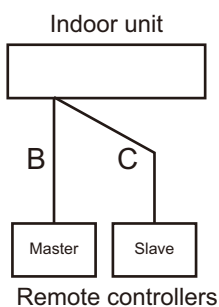

A, B, C: Remote controller cable
 $A \leq 500$ m; $B+C \leq 500$ m

Multiple installation method described above is prohibited to combine with 2-wired type and 3-wired type.

■ Group control

With a single remote controller, up to 16 units can be simultaneously operated.

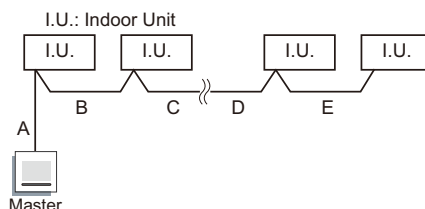

A, B, C, D, E : Remote controller cable. (Refer to Chapter 2-4. "[Wiring specifications](#)" on page 10.)

$A+B+C+D+E \leq 500$ m.

⚠ CAUTION

Group control is only possible between units with remote controllers of the same type. After confirming that the connected remote controllers have same model name by checking the rear side of the remote controller or "Chapter 13-1. [Controllers](#)" on page 77", perform the group control.

2-2. Overview

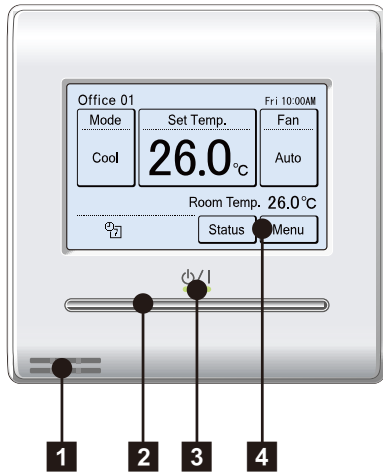

Display panel

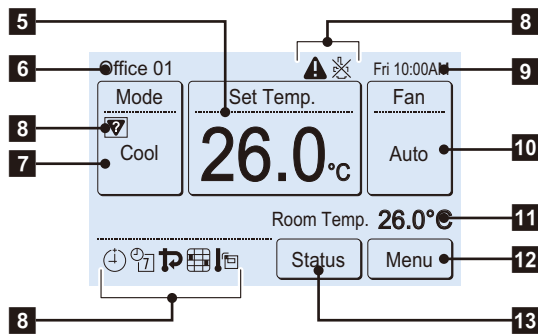

1 Remote temperature sensor (inside)

2 On/off button

Operable only while displaying the “Monitor mode” screen.

3 LED lamp (operation indicator)

4 Touch panel display

5 Set temperature

Operating temperature can be set.

6 Remote controller group name

7 Mode

Operation mode can be set.

8 Status icons

9 Clock

10 Fan

Fan speed can be set.

11 Room temperature

12 Menu

Various settings can be set.

13 Status

Status of the indoor unit and error can be checked.

NOTE: Functions may differ by type of the indoor unit.
For details, refer to the operation manual.

2-3. Specifications

Dimensions and other specifications on the wired remote controller are as follows.

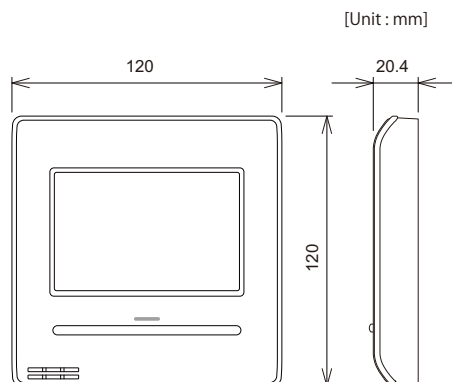

Display	3.8-inch FSTN LCD (255 × 160 dots) with touch panel	
Dimensions (H × W × D)	mm	120 × 120 × 20.4
Weight	g	220
Input voltage	V	DC 12
Power consumption	W	Max. 0.3
Usage temperature range	°C	0 to 40
Usage humidity range	%	20 to 90 (no condensation)
Storage temperature range	°C	-10 to 60
Storage humidity range	%	20 to 90 (no condensation)

2-4. Wiring specifications

Use	Cable size	Wire type	Remarks
Remote controller cable	0.33 to 1.25 mm ²	Non-polar 2-core	Use sheathed PVC cable.

NOTE: Use shielded cable (locally purchased) in accordance with the regional cable standard.

3. Specifications

3-1. Models: AUXG18LRLB and AUXG24LRLB

Type				Cassette			
				Inverter heat pump			
Model name				AUXG18LRLB	AUXG24LRLB		
Power supply				230 V ~ 50 Hz			
Available voltage range				198—264 V			
Capacity	Cooling	Rated	kW	5.2	6.8		
			Btu/h	17,700	23,200		
		Min.—Max.	kW	0.90—6.50	0.90—8.00		
	Heating	Rated	Btu/h	3,100—22,200	3,100—27,300		
			kW	6.0	7.8		
		Min.—Max.	Btu/h	20,500	26,600		
Input power	Cooling	Rated	kW	1.42	2.16		
			Max.	2.28	3.08		
		Heating	Rated	1.50	2.18		
	Fan	HIGH	MED	W	3.08	4.22	
					LOW	16	21
			QUIET	12	16		
		Heating	MED	W	11	13	
					LOW	7	9
			QUIET	11	13		
	Current	Cooling	Rated	A	6.2	9.5	
		Heating			6.6	9.6	
	Power factor	Cooling		%	99.6	98.9	
Heating		98.8			98.7		
EER	Cooling	kW/kW		3.66	3.15		
COP	Heating			4.00	3.58		
Moisture removal			L/h (pints/h)	2.2 (3.9)	2.7 (4.8)		
Maximum operating current *1			Cooling	10.0	13.5		
			Heating	13.5	18.5		
Fan	Airflow rate	Cooling	m ³ /h	HIGH	1,050	1,150	
				MED	960	1,050	
				LOW	900	980	
		QUIET		780	870		
		Heating		HIGH	1,050	1,150	
				MED	960	1,050	
	LOW		900	980			
	Type × Q'ty			Turbo fan × 1			
	Motor output			W	81		
	Sound pressure level *2			Cooling	HIGH	33	35
					MED	32	33
					LOW	31	32
QUIET					28	29	
Heating				HIGH	33	35	
				MED	32	33	
				LOW	31	32	
				QUIET	28	29	
Sound power level			Cooling	47	49		
			Heating	47	49		
Heat exchanger type			Dimensions (H × W × D)	210 × 2,127 × 13.3 210 × 2,061 × 13.3			
			Fin pitch	1.2			
			Rows × Stages	2 × 10			
			Pipe type	Copper tube			
			Fin type	Aluminum			
Dimensions (H × W × D)	Net	mm	246 × 840 × 840				
	Gross		298 × 960 × 950				
Weight	Net	kg	24				
	Gross		29				
Connection pipe	Size	Liquid	Ø 6.35 (Ø 1/4)				
		Gas	Ø 12.70 (Ø 1/2)	Ø 15.88 (Ø 5/8)			
	Method	Flare					
Drain hose	Material	PVC(VP25)					
	Size	Ø 25 (I.D.), Ø 32 (O.D.)					
Operation range			Cooling	°C	18 to 32		
			%RH	80 or less			
			Heating	°C	16 to 30		
Cassette grille			Material	PS			
			Color			White	
			Approximate color of MUNSELL N 9.25/				
			Dimensions (H × W × D)	Net	mm	53 × 950 × 950	
				Gross		110 × 1,000 × 1,010	
Weight	Net	kg	6.0				
	Gross		10.5				

Type	Cassette	
	Inverter heat pump	
Model name	AUXG18LRLB	AUXG24LRLB
Remote controller type	Wired (Wireless [option])	
NOTES: <ul style="list-style-type: none"> • Specifications are based on the following conditions: <ul style="list-style-type: none"> – Cooling: Indoor temperature of 27 °CDB/19 °CWB, and outdoor temperature of 35 °CDB/24 °CWB. – Heating: Indoor temperature of 20 °CDB/15 °CWB, and outdoor temperature of 7 °CDB/6 °CWB. – Pipe length: 5 m, Height difference: 0 m. (Between outdoor unit and indoor unit.) • Protective function might work when using it outside the operation range. • *1: Maximum current: <ul style="list-style-type: none"> – The maximum value when operated within the operation range. – The total current of indoor unit and outdoor unit. • *2: Sound pressure level: <ul style="list-style-type: none"> – Measured values in manufacturer's anechoic chamber. – Because of the surrounding sound environment, the sound levels measured in actual installation conditions might be higher than the specified values here. 		

Model name			AUXG18LRLB	AUXG24LRLB
Energy efficiency class	Cooling		A ⁺⁺	A ⁺⁺
	Heating (Average)		A ⁺	A ⁺
Pdesign	Cooling	kW	5.2 (35°C)	6.8 (35°C)
	Heating (Average)		4.3 (-10°C)	6.0 (-10°C)
SEER	Cooling	kWh/kWh	7.05	6.60
SCOP	Heating (Average)		4.40	4.20
Annual energy consumption	QCE		258	361
	QHE (Average)		1,367	1,999
Sound power level	Cooling	HIGH	dB (A)	47
	Heating			47

3-2. Models: AUXG30LRLB, AUXG36LRLB, AUXG45LRLB, and AUXG54LRLB

Type				Cassette					
				Inverter heat pump					
Model name				AUXG30LRLB	AUXG36LRLB	AUXG45LRLB	AUXG54LRLB		
Power supply				230 V ~ 50 Hz					
Available voltage range				198—264 V					
Capacity	Cooling	Rated	kW	8.5	9.5	12.5	13.3		
			Btu/h	29,000	32,400	42,700	45,400		
		Min.—Max.	kW	2.8—10.0	2.8—11.2	4.0—14.0	4.5—14.5		
	Heating	Rated	kW	10.0	10.8	14.0	15.8		
			Btu/h	34,100	36,900	47,800	53,900		
		Min.—Max.	kW	2.70—11.20	2.7—12.7	4.2—16.2	4.7—16.5		
				Btu/h	9,200—38,200	9,200—43,300	14,300—55,300	16,000—56,300	
Input power	Cooling	Rated	kW	2.56	2.96	3.85	4.38		
				Max.	3.88	4.56	4.70	4.94	
	Heating	Rated	2.77	2.91	3.73	4.58			
			Max.	3.88	4.56	4.70	4.94		
	Fan	HIGH	MED	W	52	87	106	129	
					39	52	60	95	
					31	39	45	55	
					20	23	30	34	
Current	Cooling	Rated	A	11.2	13.0	16.8	19.1		
	Heating			12.2	12.7	16.3	20.0		
Power factor	Cooling		%	99.4	99.0	99.6	99.2		
	Heating			98.7	99.6	99.5	99.6		
EER	Cooling		kW/kW	3.32	3.21	3.25	3.04		
COP	Heating			3.61	3.71	3.75	3.45		
Moisture removal				L/h (pints/h)	2.5 (4.4)	3.3 (5.8)	4.5 (7.9)	5.0 (8.8)	
Maximum operating current *1				A	17.0	20.0	20.5	21.5	
					17.0	20.0	20.5	21.5	
Fan	Airflow rate	Cooling	m ³ /h	HIGH	1,600	1,900	2,000	2,100	
				MED	1,400	1,590	1,650	1,780	
				LOW	1,270	1,420	1,460	1,600	
				QUIET	1,150	1,180	1,300	1,320	
		Heating	HIGH	1,600	1,900	2,000	2,100		
			MED	1,400	1,590	1,650	1,780		
			LOW	1,270	1,420	1,460	1,600		
			QUIET	1,150	1,180	1,300	1,320		
	Type × Q'ty				Turbo fan × 1				
	Motor output				W	81			
	Sound pressure level *2	Cooling	HIGH	dB (A)	40	44	46	47	
					MED	38	41	42	43
LOW					36	38	39	40	
QUIET					33	34	35	36	
Heating		HIGH	dB (A)	40	44	46	47		
				MED	38	41	42	43	
				LOW	36	38	39	40	
				QUIET	33	34	35	36	
Sound power level	Cooling	HIGH	dB (A)	54	58	60	61		
	Heating			54	58	60	61		
Heat exchanger type	Dimensions (H × W × D)		mm	252 × 2,124 × 13.3		252 × 2,124 × 13.3			
				252 × 2,062 × 13.3		252 × 2,062 × 13.3			
	Fin pitch		1.2		1.3				
	Rows × Stages		2 × 12		3 × 12				
	Pipe type		Copper tube						
Fin type		Aluminum							
Dimensions (H × W × D)	Net		mm	288 × 840 × 840					
	Gross			350 × 960 × 950					
Weight	Net		kg	26		29			
	Gross			32		34			
Connection pipe	Size	Liquid	mm (in)	Ø 9.52 (Ø 3/8)					
		Gas		Ø 15.88 (Ø 5/8)					
Method		Brazing							
Drain hose	Material		PVC(VP25)						
	Size		Ø 25 (I.D.), Ø 32 (O.D.)						
Operation range	Cooling	°C		18 to 32					
		%RH		80 or less					
	Heating	°C		16 to 30					
Cassette grille	Material		PS						
	Color		White Approximate color of MUNSSELL N 9.25/						
	Dimensions (H × W × D)	Net		mm	53 × 950 × 950				
		Gross			110 × 1,000 × 1,010				
	Weight	Net		kg	6.0				
		Gross			10.5				

Type	Cassette			
	Inverter heat pump			
Model name	AUXG30LRLB	AUXG36LRLB	AUXG45LRLB	AUXG54LRLB
Remote controller type	Wired (Wireless [option])			
NOTES: <ul style="list-style-type: none"> • Specifications are based on the following conditions: <ul style="list-style-type: none"> – Cooling: Indoor temperature of 27 °CDB/19 °CWB, and outdoor temperature of 35 °CDB/24 °CWB. – Heating: Indoor temperature of 20 °CDB/15 °CWB, and outdoor temperature of 7 °CDB/6 °CWB. – Pipe length: 5 m, Height difference: 0 m. (Between outdoor unit and indoor unit.) • Protective function might work when using it outside the operation range. • *1: Maximum current: <ul style="list-style-type: none"> – The maximum value when operated within the operation range. – The total current of indoor unit and outdoor unit. • *2: Sound pressure level: <ul style="list-style-type: none"> – Measured values in manufacturer's anechoic chamber. – Because of the surrounding sound environment, the sound levels measured in actual installation conditions might be higher than the specified values here. 				

Model name			AUXG30LRLB	AUXG36LRLB
Energy efficiency class	Cooling		A ⁺⁺	A ⁺⁺
	Heating (Average)		A ⁺	A ⁺
Pdesign	Cooling	kW	8.5 (35°C)	9.5 (35°C)
	Heating (Average)		8.0 (-10°C)	8.7 (-10°C)
SEER	Cooling	kWh/kWh	6.70	6.40
SCOP	Heating (Average)		4.30	4.30
Annual energy consumption	QCE		444	519
	QHE (Average)		2,604	2,833
Sound power level	Cooling	HIGH	dB (A)	54
	Heating			54

4. Dimensions

4-1. Models: AUXG18LRB and AUXG24LRB

■ Ceiling opening and hanging bolt pitch

Unit: mm

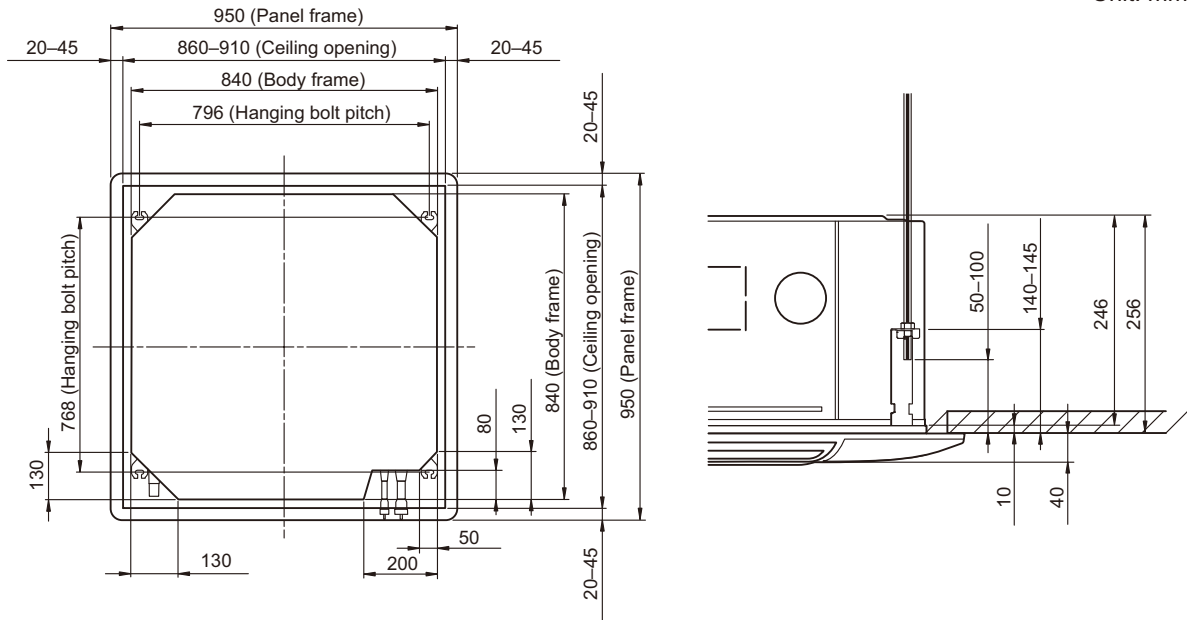

■ Refrigerant piping and drain piping positions

Unit: mm

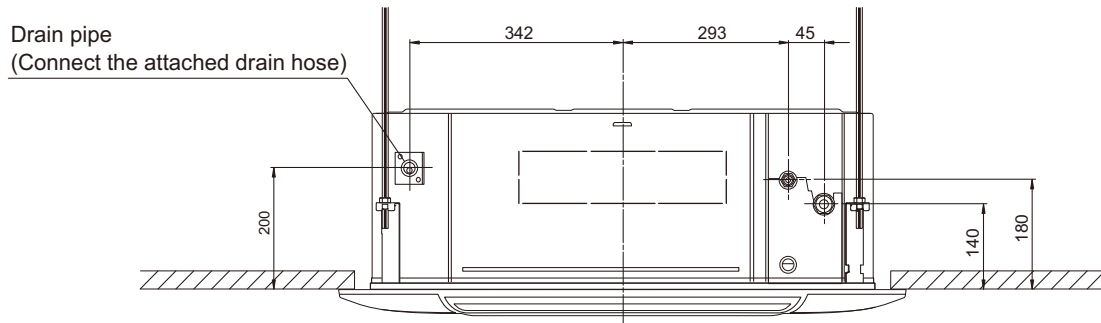

Airflow split-flow duct and fresh-air inlet positions

Unit: mm

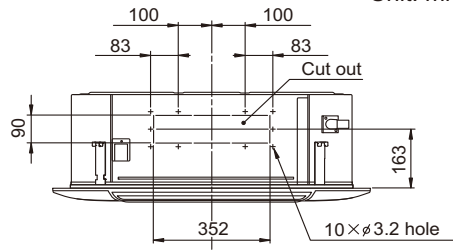
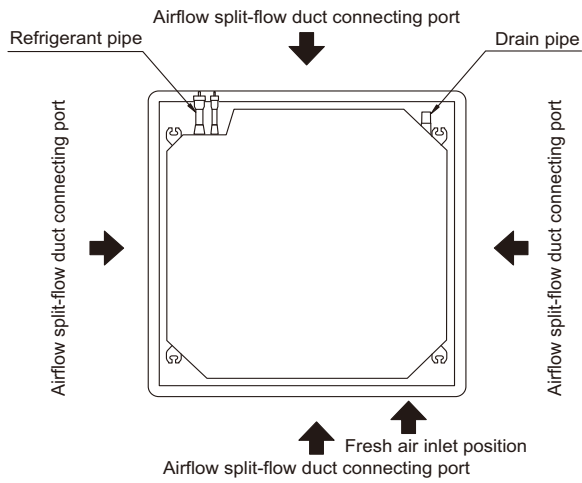

Detailed diagram of branched duct connecting port (4 sides)

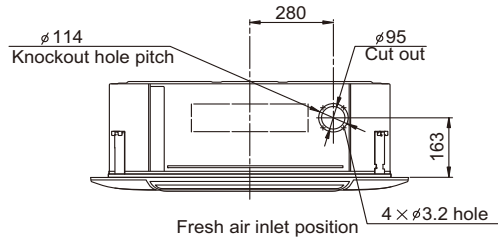

4-2. Models: AUXG30LRLB, AUXG36LRLB, AUXG45LRLB, and AUXG54LRLB

■ Ceiling opening and hanging bolt pitch

Unit: mm

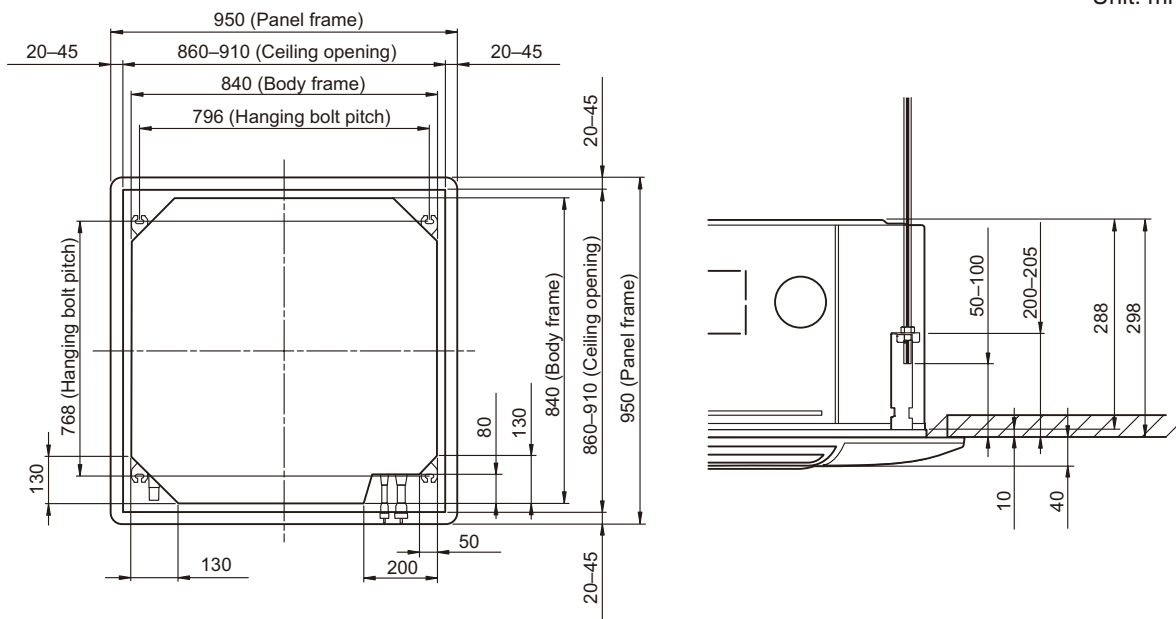

■ Refrigerant piping and drain piping positions

Unit: mm

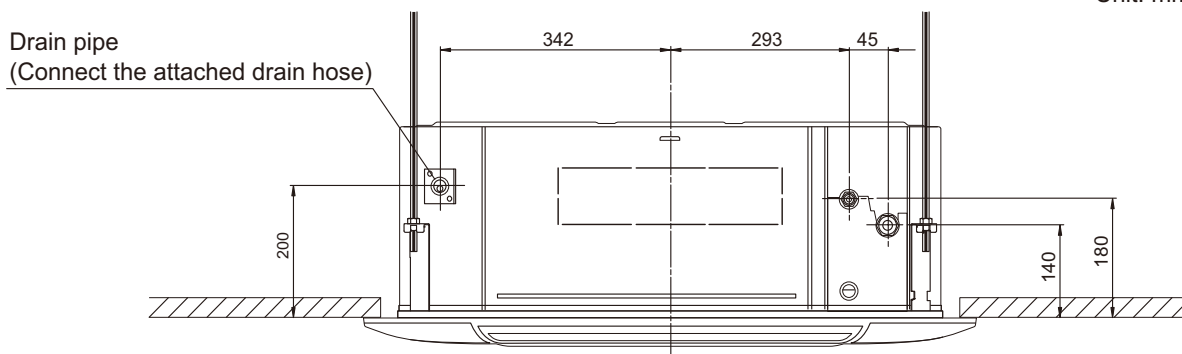

■ Airflow split-flow duct and fresh-air inlet positions

Unit: mm

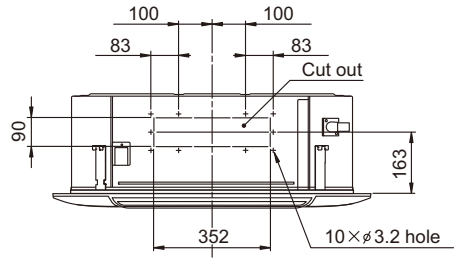
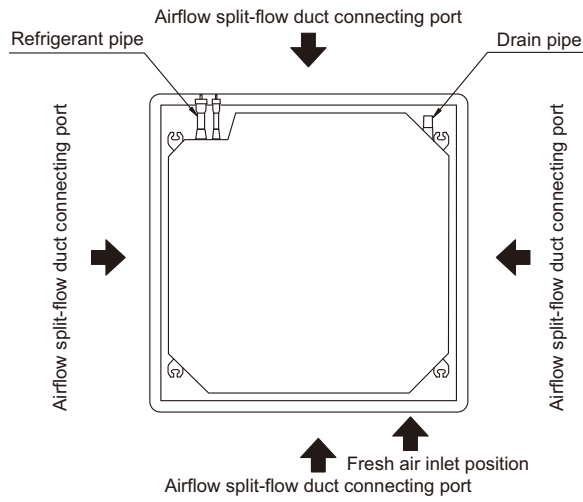

Detailed diagram of branched duct connecting port (4 sides)

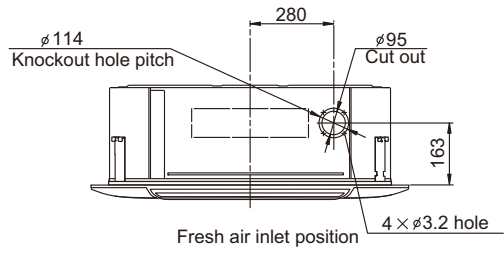

4-3. Installation space requirement

Provide sufficient installation space for product safety.

For 4-direction setting (AUXG18LRB and AUXG24LRB):

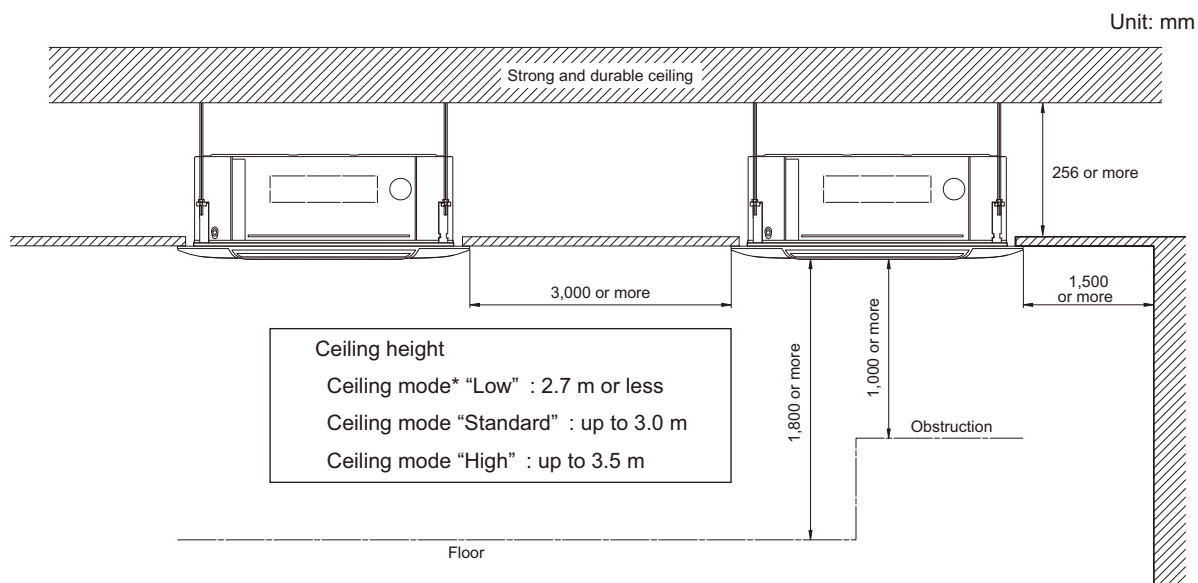

*: For the details of position adjustment by ceiling mode, refer to "Contents of function setting".

For 4-direction setting (AUXG30LRB, AUXG36LRB, AUXG45LRB, and AUXG54LRB):

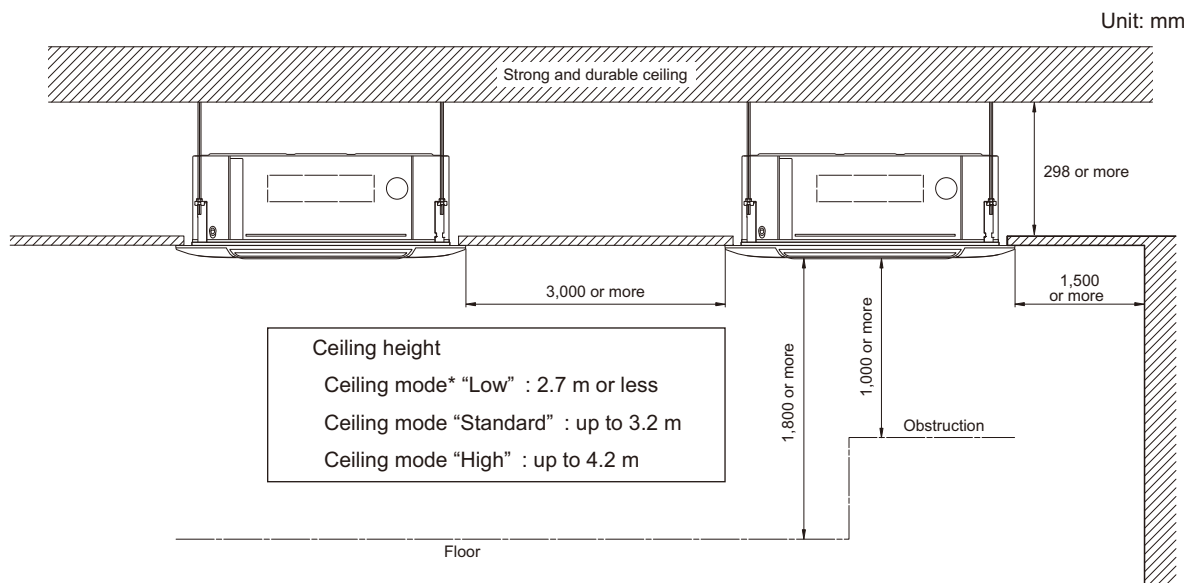

*: For the details of position adjustment by ceiling mode, refer to "Contents of function setting".

For 3-direction setting:

Unit: mm

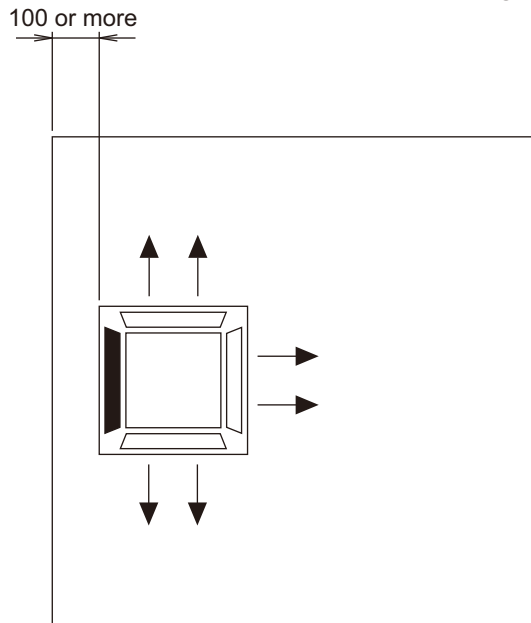

NOTES:

- To set “3-direction”, optional Air outlet shutter plate (UTR-YDZK) must be installed, and the “outlet-direction” need to be switched to “3-way” by remote controller.
- The ceiling height cannot be set in the 3-way outlet mode. Therefore, ceiling height setting change by function setting 20 is prohibited. For details, refer to “[Contents of function setting](#)” on page 69.

Human sensor(Optional)

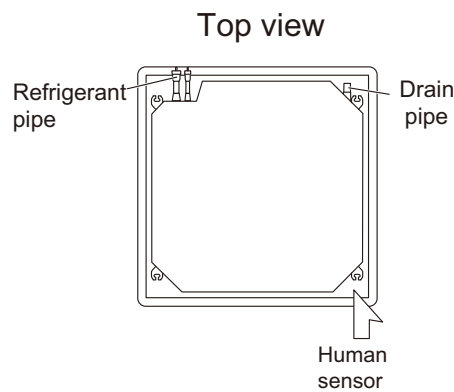

Example of sensitivity range:

When the installation height gets higher, the temperature sensitivity decreases.

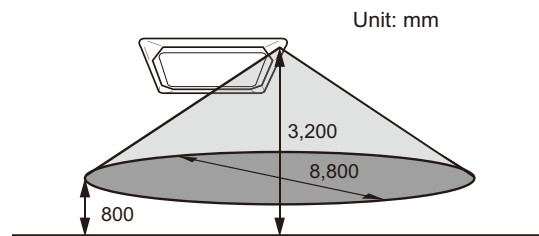

Equal sensitivity range of temperature	Ceiling height	3,200 mm
	Detecting position	800 mm from floor surface

⚠ CAUTION

Do not place large objects near the human sensor. Also keep heating units outside the sensor’s detection area.

5. Wiring diagram

5-1. Models: AUXG18LRLB, AUXG24LRLB, AUXG30LRLB, AUXG36LRLB, AUXG45LRLB, and AUXG54LRLB

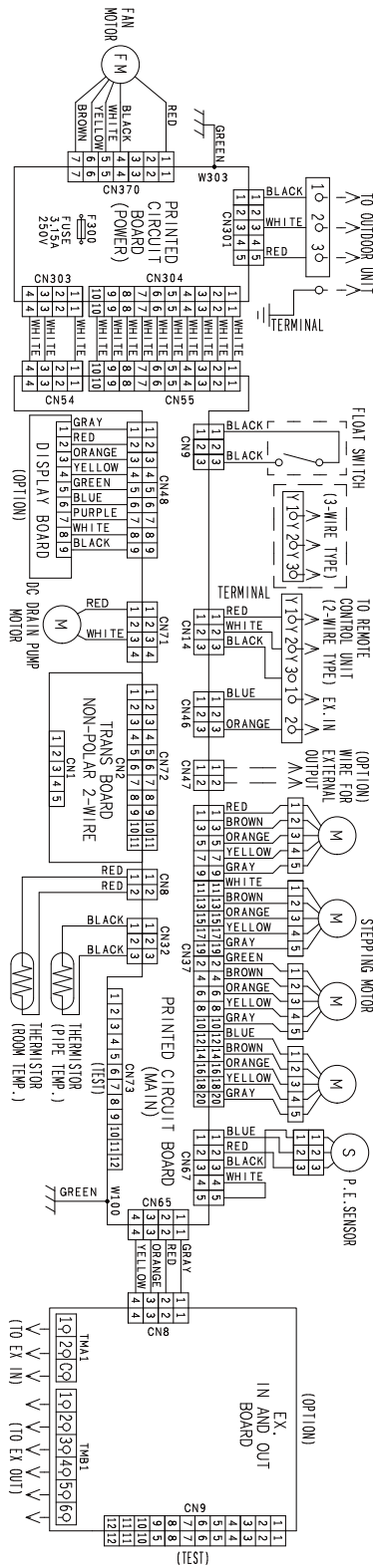

6. Capacity table

Capacity tables show each of following values calculated based on the outdoor temperature and the indoor temperature, under given Airflow Rate (AFR):

For cooling capacity: Total Capacity (TC), Sensible Heat Capacity (SHC), and Input Power (IP)

For heating capacity: Total Capacity (TC) and Input Power (IP)

6-1. Cooling capacity

NOTE: Values mentioned in the table are calculated based on the maximum capacity.

■ Model: AUXG18LRLB

AFR	m ³ /h	1,050
-----	-------------------	-------

		Indoor temperature																				
		18			21			23			25			27			29			32		
		12			15			16			18			19			21			23		
Outdoor temperature	°CDB	TC	SHC	IP	TC	SHC	IP	TC	SHC	IP	TC	SHC	IP	TC	SHC	IP	TC	SHC	IP	TC	SHC	IP
	°CWB	kW			kW			kW			kW			kW			kW			kW		
	-15	4.88	4.10	0.25	5.44	4.11	0.25	5.63	4.47	0.25	6.00	4.48	0.26	6.19	4.85	0.26	6.55	4.83	0.26	6.92	5.14	0.26
	-10	4.91	4.10	0.41	5.47	4.11	0.41	5.66	4.48	0.41	6.03	4.49	0.42	6.22	4.85	0.42	6.58	4.84	0.43	6.96	5.15	0.43
	0	4.80	4.02	0.48	5.35	4.05	0.49	5.52	4.40	0.49	5.89	4.41	0.49	6.07	4.77	0.50	6.44	4.75	0.50	6.80	5.06	0.51
	5	4.66	3.96	0.59	5.19	3.99	0.60	5.37	4.33	0.60	5.72	4.35	0.61	5.90	4.70	0.61	6.25	4.68	0.62	6.61	4.98	0.62
	10	4.51	3.88	0.70	5.03	3.91	0.71	5.19	4.24	0.71	5.53	4.26	0.71	5.71	4.61	0.72	6.05	4.58	0.73	6.39	4.89	0.73
	15	4.52	3.89	0.61	5.04	3.92	0.62	5.20	4.26	0.62	5.56	4.27	0.63	5.72	4.62	0.63	6.06	4.59	0.64	6.42	4.89	0.65
	20	5.69	4.18	1.29	6.33	4.21	1.31	6.55	4.58	1.32	6.98	4.59	1.33	7.20	4.96	1.34	7.63	4.93	1.35	8.06	5.25	1.36
	25	5.45	4.17	1.44	6.07	4.19	1.47	6.28	4.57	1.47	6.69	4.58	1.49	6.90	4.94	1.49	7.31	4.92	1.50	7.73	5.24	1.52
	30	5.20	4.15	1.59	5.80	4.18	1.62	6.00	4.54	1.63	6.38	4.55	1.65	6.58	4.92	1.65	6.98	4.89	1.66	7.38	5.21	1.68
35	5.14	4.14	1.86	5.72	4.17	1.89	5.92	4.53	1.90	6.31	4.54	1.92	6.50	4.90	1.92	6.89	4.88	1.92	7.29	5.20	1.92	
40	3.76	3.44	1.28	4.19	3.47	1.30	4.33	3.76	1.30	4.61	3.77	1.31	4.75	4.08	1.32	5.04	4.07	1.33	5.33	4.33	1.35	
46	2.67	2.93	0.95	2.97	2.96	0.97	3.08	3.22	0.97	3.29	3.22	0.98	3.39	3.48	0.99	3.59	3.47	1.00	3.79	3.69	1.01	

■ Model: AUXG24LRLB

AFR	m ³ /h	1,150
-----	-------------------	-------

		Indoor temperature																				
		18			21			23			25			27			29			32		
		12			15			16			18			19			21			23		
Outdoor temperature	°CDB	TC	SHC	IP	TC	SHC	IP	TC	SHC	IP	TC	SHC	IP	TC	SHC	IP	TC	SHC	IP	TC	SHC	IP
	°CWB	kW			kW			kW			kW			kW			kW			kW		
	-15	5.59	4.51	0.36	6.23	4.53	0.36	6.44	4.93	0.37	6.86	4.94	0.37	7.07	5.34	0.38	7.50	5.32	0.38	7.92	5.67	0.38
	-10	5.62	4.52	0.60	6.26	4.54	0.60	6.47	4.94	0.61	6.90	4.95	0.61	7.11	5.35	0.62	7.54	5.33	0.62	7.96	5.68	0.63
	0	5.52	4.47	0.64	6.15	4.49	0.65	6.36	4.89	0.66	6.78	4.90	0.66	6.99	5.29	0.67	7.41	5.27	0.67	7.83	5.62	0.68
	5	5.33	4.37	0.78	5.94	4.40	0.79	6.14	4.78	0.80	6.55	4.80	0.80	6.75	5.18	0.81	7.15	5.16	0.82	7.56	5.50	0.82
	10	5.12	4.26	0.91	5.71	4.29	0.92	5.90	4.66	0.93	6.29	4.68	0.94	6.49	5.05	0.94	6.87	5.03	0.95	7.26	5.36	0.96
	15	5.25	4.33	0.76	5.85	4.35	0.77	6.05	4.73	0.78	6.45	4.75	0.79	6.65	5.13	0.79	7.05	5.11	0.80	7.44	5.44	0.81
	20	6.75	5.11	1.65	7.52	5.15	1.67	7.77	5.59	1.68	8.29	5.61	1.70	8.54	6.06	1.71	9.05	6.04	1.73	9.57	6.43	1.74
	25	6.41	4.93	1.78	7.14	4.96	1.81	7.38	5.39	1.82	7.87	5.41	1.84	8.11	5.84	1.85	8.60	5.82	1.86	9.08	6.20	1.88
	30	6.07	4.75	1.98	6.76	4.78	2.01	6.99	5.20	2.02	7.46	5.22	2.04	7.69	5.63	2.05	8.15	5.61	2.07	8.61	5.98	2.09
35	6.32	4.88	2.52	7.04	4.91	2.56	7.28	5.34	2.57	7.76	5.36	2.60	8.00	5.79	2.61	8.48	5.76	2.64	8.96	6.14	2.66	
40	5.22	4.31	2.10	5.81	4.34	2.14	6.01	4.72	2.15	6.41	4.73	2.17	6.61	5.11	2.18	7.00	5.09	2.20	7.40	5.42	2.22	
46	3.74	3.58	1.59	4.17	3.60	1.61	4.31	3.91	1.62	4.60	3.92	1.64	4.74	4.24	1.65	5.02	4.22	1.66	5.31	4.50	1.68	

Model: AUXG30LRLB

AFR	m ³ /h	1,600
-----	-------------------	-------

		Indoor temperature																				
		18			21			23			25			27			29			32		
		12			15			16			18			19			21			23		
Outdoor temperature	°CDB	TC	SHC	IP	TC	SHC	IP	TC	SHC	IP	TC	SHC	IP	TC	SHC	IP	TC	SHC	IP	TC	SHC	IP
	-15	8.67	6.58	1.20	9.66	6.62	1.22	9.99	7.20	1.22	10.65	7.22	1.22	10.98	7.80	1.24	11.64	7.77	1.25	12.29	8.27	1.27
	-10	8.52	6.38	1.64	9.49	6.42	1.66	9.81	6.98	1.67	10.46	7.00	1.69	10.79	7.56	1.70	11.44	7.53	1.72	12.08	8.02	1.73
	0	8.12	6.26	2.11	9.04	6.30	2.15	9.35	6.85	2.16	9.97	6.87	2.18	10.28	7.42	2.19	10.90	7.39	2.21	11.51	7.87	2.23
	5	7.99	6.11	2.14	8.90	6.14	2.17	9.21	6.68	2.19	9.81	6.70	2.21	10.12	7.23	2.22	10.73	7.20	2.24	11.33	7.68	2.26
	10	7.96	6.19	2.19	8.87	6.23	2.23	9.17	6.77	2.24	9.77	6.79	2.26	10.07	7.34	2.27	10.67	7.31	2.29	11.28	7.79	2.32
	15	8.63	6.48	2.41	9.62	6.52	2.45	9.95	7.09	2.46	10.60	7.11	2.49	10.93	7.68	2.50	11.59	7.65	2.53	12.24	8.14	2.55
	20	9.82	7.03	2.97	10.94	7.07	3.01	11.31	7.69	3.03	12.06	7.71	3.06	12.43	8.33	3.08	13.18	8.30	3.11	13.92	8.84	3.14
	25	9.48	6.89	3.31	10.56	6.93	3.36	10.92	7.53	3.38	11.64	7.56	3.41	12.00	8.16	3.43	12.72	8.13	3.46	13.44	8.66	3.50
	30	8.81	6.70	3.35	9.81	6.74	3.39	10.15	7.32	3.41	10.81	7.35	3.44	11.15	7.93	3.46	11.82	7.90	3.50	12.49	8.42	3.53
35	7.90	6.12	3.35	8.80	6.16	3.40	9.10	6.69	3.42	9.70	6.71	3.45	10.00	7.25	3.47	10.60	7.22	3.51	11.20	7.69	3.54	
40	6.16	5.13	2.94	6.86	5.16	2.99	7.09	5.61	3.00	7.56	5.63	3.04	7.80	6.08	3.05	8.27	6.06	3.08	8.73	6.45	3.11	
46	5.44	4.92	2.91	6.06	4.95	2.96	6.27	5.39	2.97	6.68	5.40	3.00	6.89	5.83	3.02	7.30	5.81	3.05	7.71	6.19	3.08	

Model: AUXG36LRLB

AFR	m ³ /h	1,900
-----	-------------------	-------

		Indoor temperature																				
		18			21			23			25			27			29			32		
		12			15			16			18			19			21			23		
Outdoor temperature	°CDB	TC	SHC	IP	TC	SHC	IP	TC	SHC	IP	TC	SHC	IP	TC	SHC	IP	TC	SHC	IP	TC	SHC	IP
	-15	9.33	7.37	1.29	10.39	7.41	1.31	10.74	8.06	1.32	11.45	8.08	1.33	11.80	8.73	1.34	12.51	8.70	1.35	13.22	9.26	1.36
	-10	9.22	7.23	1.69	10.27	7.27	1.71	10.62	7.90	1.72	11.32	7.93	1.74	11.67	8.56	1.75	12.37	8.53	1.77	13.07	9.08	1.78
	0	8.77	7.13	2.18	9.77	7.17	2.22	10.10	7.80	2.23	10.77	7.82	2.25	11.10	8.45	2.26	11.77	8.41	2.29	12.44	8.96	2.31
	5	8.69	6.98	2.25	9.68	7.02	2.28	10.01	7.64	2.29	10.67	7.66	2.32	11.00	8.27	2.33	11.66	8.24	2.35	12.32	8.78	2.38
	10	8.62	7.06	2.25	9.60	7.10	2.29	9.93	7.72	2.30	10.58	7.75	2.32	10.91	8.37	2.34	11.56	8.33	2.36	12.22	8.88	2.38
	15	9.17	7.17	2.42	10.21	7.22	2.46	10.56	7.85	2.47	11.25	7.87	2.50	11.60	8.50	2.51	12.30	8.47	2.54	13.00	9.02	2.56
	20	10.70	7.92	2.99	11.92	7.97	3.03	12.33	8.66	3.05	13.14	8.69	3.08	13.54	9.39	3.10	14.36	9.35	3.13	15.17	9.96	3.16
	25	10.64	8.02	3.32	11.86	8.06	3.38	12.26	8.77	3.39	13.07	8.79	3.43	13.47	9.50	3.45	14.28	9.46	3.48	15.09	10.08	3.51
	30	10.24	7.76	4.05	11.40	7.81	4.11	11.79	8.49	4.13	12.57	8.51	4.17	12.96	9.19	4.19	13.73	9.16	4.24	14.51	9.75	4.28
35	8.85	6.78	4.03	9.86	6.82	4.10	10.19	7.42	4.12	10.86	7.44	4.16	11.20	8.04	4.18	11.87	8.01	4.22	12.54	8.53	4.27	
40	6.80	5.96	3.09	7.58	6.00	3.14	7.84	6.52	3.16	8.35	6.54	3.19	8.61	7.07	3.20	9.13	7.04	3.24	9.65	7.50	3.27	
46	6.11	5.84	2.96	6.81	5.87	3.01	7.04	6.39	3.02	7.50	6.41	3.05	7.74	6.92	3.07	8.20	6.89	3.10	8.67	7.34	3.13	

Model: AUXG45LRLB

AFR	m ³ /h	2,000
-----	-------------------	-------

		Indoor temperature																				
		18			21			23			25			27			29			32		
		12			15			16			18			19			21			23		
Outdoor temperature	°CDB	TC	SHC	IP	TC	SHC	IP	TC	SHC	IP	TC	SHC	IP	TC	SHC	IP	TC	SHC	IP	TC	SHC	IP
	-15	11.34	8.71	2.56	12.63	8.76	2.60	13.06	9.52	2.62	13.92	9.55	2.64	14.35	10.32	2.66	15.21	10.28	2.68	16.07	10.95	2.71
	-10	11.44	8.70	2.46	12.74	8.75	2.50	13.17	9.51	2.51	14.04	9.55	2.54	14.48	10.31	2.55	15.35	10.27	2.58	16.21	10.94	2.60
	0	11.55	8.77	2.23	12.87	8.83	2.26	13.31	9.60	2.28	14.18	9.63	2.30	14.62	10.40	2.31	15.50	10.35	2.33	16.38	11.03	2.36
	5	11.37	8.78	2.30	12.67	8.84	2.34	13.10	9.61	2.35	13.97	9.64	2.37	14.40	10.41	2.39	15.26	10.37	2.41	16.12	11.04	2.43
	10	11.11	8.78	2.49	12.37	8.83	2.53	12.79	9.60	2.54	13.64	9.63	2.57	14.06	10.40	2.58	14.90	10.36	2.61	15.74	11.04	2.63
	15	10.84	8.68	2.69	12.07	8.74	2.73	12.48	9.50	2.74	13.31	9.53	2.77	13.72	10.29	2.78	14.54	10.25	2.81	15.37	10.92	2.84
	20	11.22	8.69	3.15	12.49	8.74	3.20	12.92	9.50	3.22	13.77	9.53	3.25	14.20	10.29	3.27	15.05	10.25	3.30	15.90	10.92	3.33
	25	11.10	8.78	3.36	12.36	8.83	3.41	12.79	9.60	3.43	13.63	9.63	3.46	14.05	10.40	3.48	14.89	10.36	3.51	15.74	11.03	3.55
	30	11.34	8.84	4.27	12.63	8.89	4.34	13.06	9.67	4.36	13.92	9.70	4.41	14.35	10.48	4.43	15.21	10.43	4.43	16.07	11.11	4.43
35	11.06	8.82	4.53	12.32	8.87	4.60	12.74	9.64	4.62	13.58	9.68	4.67	14.00	10.45	4.69	14.84	10.41	4.69	15.68	11.09	4.69	
40	8.79	7.66	3.92	9.79	7.83	3.98	10.13	8.52	4.00	10.80	8.54	4.04	11.13	9.23	4.06	11.80	9.19	4.06	12.47	9.79	4.06	
46	6.69	6.63	3.24	7.45	6.87	3.29	7.71	7.47	3.31	8.22	7.49	3.34	8.47	8.09	3.36	8.98	8.06	3.36	9.49	8.58	3.36	

Model: AUXG54LRB

AFR	m ³ /h	2,100
-----	-------------------	-------

		Indoor temperature																							
		18			21			23			25			27			29			32					
		12			15			16			18			19			21			23					
Outdoor temperature	°CDB	TC	SHC	IP	TC	SHC	IP	TC	SHC	IP	TC	SHC	IP	TC	SHC	IP	TC	SHC	IP	TC	SHC	IP	TC	SHC	IP
	°CWB	kW			kW			kW			kW			kW			kW			kW					
	-15	11.73	9.03	2.69	13.07	9.08	2.73	13.52	9.87	2.75	14.41	9.90	2.78	14.85	10.69	2.79	15.74	10.65	2.82	16.64	11.35	2.85			
	-10	11.72	9.04	2.59	13.06	9.10	2.63	13.50	9.89	2.64	14.39	9.92	2.67	14.84	10.71	2.68	15.73	10.67	2.71	16.62	11.37	2.73			
	0	11.84	9.12	2.33	13.19	9.17	2.36	13.64	9.97	2.37	14.54	10.01	2.40	14.99	10.81	2.41	15.89	10.76	2.43	16.78	11.46	2.46			
	5	11.60	8.96	2.42	12.92	9.02	2.46	13.37	9.80	2.47	14.25	9.83	2.50	14.69	10.62	2.51	15.57	10.58	2.54	16.45	11.27	2.56			
	10	11.44	8.90	2.54	12.74	8.95	2.58	13.18	9.73	2.59	14.04	9.76	2.62	14.48	10.54	2.63	15.35	10.50	2.66	16.22	11.18	2.68			
	15	11.22	8.99	2.81	12.50	9.04	2.85	12.92	9.83	2.86	13.77	9.86	2.89	14.20	10.65	2.91	15.05	10.61	2.93	15.90	11.30	2.96			
	20	12.06	9.55	3.73	13.43	9.61	3.79	13.89	10.45	3.81	14.81	10.48	3.85	15.26	11.32	3.87	16.18	11.27	3.90	17.10	12.01	3.94			
	25	11.82	9.10	4.31	13.17	9.15	4.38	13.62	9.95	4.40	14.52	9.98	4.45	14.97	10.78	4.47	15.86	10.73	4.51	16.76	11.44	4.56			
30	11.62	8.98	4.52	12.95	9.04	4.59	13.39	9.82	4.61	14.27	9.86	4.66	14.71	10.64	4.68	15.59	10.60	4.68	16.48	11.29	4.68				
35	11.46	8.89	4.75	12.76	8.95	4.82	13.20	9.73	4.85	14.07	9.76	4.90	14.50	10.54	4.92	15.37	10.50	4.92	16.24	11.18	4.92				
40	9.11	8.03	3.94	10.15	8.21	4.00	10.49	8.93	4.02	11.18	8.96	4.06	11.53	9.67	4.08	12.22	9.63	4.08	12.91	10.26	4.08				
46	6.94	6.91	3.26	7.73	7.16	3.31	7.99	7.78	3.33	8.52	7.81	3.36	8.78	8.43	3.38	9.31	8.40	3.38	9.83	8.94	3.38				

6-2. Heating capacity

NOTE: Values mentioned in the table are calculated based on the maximum capacity.

■ Model: AUXG18LRLB

AFR	m ³ /h	1,050
-----	-------------------	-------

		Indoor temperature										
		16		18		20		22		24		
Outdoor temperature	°CDB	°CWB	TC	IP	TC	IP	TC	IP	TC	IP	TC	IP
			kW		kW		kW		kW		kW	
	-15	-16	5.37	2.41	5.25	2.46	5.12	2.50	4.99	2.55	4.86	2.61
-10	-11	6.18	2.51	6.03	2.57	5.89	2.62	5.74	2.67	5.59	2.73	
-5	-7	6.96	2.59	6.80	2.64	6.63	2.70	6.47	2.73	6.30	2.73	
0	-2	7.89	2.62	7.70	2.67	7.51	2.73	7.33	2.73	7.13	2.73	
5	3	8.63	2.61	8.42	2.66	8.22	2.72	8.01	2.73	7.81	2.73	
7	6	8.39	2.24	8.20	2.28	8.00	2.33	7.80	2.38	7.59	2.42	
10	8	8.66	2.22	8.45	2.27	8.24	2.31	8.04	2.36	7.83	2.41	
15	10	7.77	1.91	7.59	1.94	7.40	1.99	7.21	2.02	7.03	2.07	
20	15	7.31	1.50	7.13	1.53	6.96	1.56	6.79	1.59	6.54	1.60	
24	18	7.45	1.49	7.27	1.52	7.09	1.55	6.92	1.58	6.74	1.61	

■ Model: AUXG24LRLB

AFR	m ³ /h	1,150
-----	-------------------	-------

		Indoor temperature										
		16		18		20		22		24		
Outdoor temperature	°CDB	°CWB	TC	IP	TC	IP	TC	IP	TC	IP	TC	IP
			kW		kW		kW		kW		kW	
	-15	-16	6.15	2.84	6.01	2.90	5.86	2.96	5.72	3.01	5.57	3.07
-10	-11	6.92	3.03	6.75	3.09	6.59	3.15	6.42	3.22	6.26	3.28	
-5	-7	7.64	3.02	7.45	3.08	7.27	3.14	7.09	3.20	6.91	3.27	
0	-2	8.59	3.00	8.38	3.06	8.18	3.12	7.97	3.18	7.77	3.25	
5	3	9.54	3.02	9.31	3.08	9.09	3.14	8.86	3.20	8.63	3.27	
7	6	9.55	2.69	9.33	2.74	9.10	2.80	8.87	2.86	8.64	2.91	
10	8	9.87	2.69	9.63	2.75	9.40	2.80	9.16	2.86	8.93	2.92	
15	10	8.97	2.07	8.76	2.12	8.54	2.16	8.33	2.20	8.11	2.25	
20	15	8.23	1.63	8.03	1.66	7.84	1.69	7.64	1.73	7.45	1.76	
24	18	8.52	1.62	8.32	1.66	8.12	1.69	7.92	1.73	7.71	1.76	

■ Model: AUXG30LRLB

AFR	m ³ /h	1,600
-----	-------------------	-------

		Indoor temperature										
		16		18		20		22		24		
Outdoor temperature	°CDB	°CWB	TC	IP	TC	IP	TC	IP	TC	IP	TC	IP
			kW		kW		kW		kW		kW	
	-15	-16	8.34	3.37	8.14	3.44	7.94	3.51	7.75	3.58	7.55	3.65
-10	-11	8.79	3.38	8.58	3.45	8.37	3.52	8.16	3.59	7.95	3.66	
-5	-7	9.55	3.41	9.32	3.48	9.09	3.55	8.86	3.62	8.64	3.69	
0	-2	10.12	3.37	9.88	3.44	9.64	3.51	9.40	3.58	9.16	3.65	
5	3	11.23	3.35	10.96	3.42	10.69	3.49	10.43	3.56	10.16	3.62	
7	6	11.76	3.33	11.48	3.40	11.20	3.47	10.92	3.54	10.64	3.61	
10	8	12.12	3.30	11.83	3.37	11.54	3.44	11.25	3.51	10.96	3.57	
15	10	10.86	2.52	10.60	2.57	10.34	2.62	10.09	2.67	9.83	2.71	
20	15	10.87	2.23	10.61	2.28	10.35	2.33	10.09	2.37	9.83	2.41	
24	18	11.31	2.25	11.04	2.30	10.78	2.34	10.51	2.39	10.24	2.43	

Model: AUXG36LRLB

AFR	m ³ /h	1,900
-----	-------------------	-------

		Indoor temperature										
Outdoor temperature	°CDB	°CWB	16		18		20		22		24	
			TC	IP	TC	IP	TC	IP	TC	IP	TC	IP
	kW		kW		kW		kW		kW		kW	
	-15	-16	9.63	3.92	9.40	4.00	9.17	4.08	8.94	4.17	8.71	4.25
-10	-11	9.70	3.96	9.47	4.04	9.24	4.13	9.01	4.21	8.77	4.29	
-5	-7	10.69	4.07	10.43	4.16	10.18	4.24	9.92	4.33	9.67	4.41	
0	-2	12.54	3.99	12.24	4.08	11.94	4.16	11.64	4.24	11.34	4.33	
5	3	13.18	3.81	12.87	3.89	12.55	3.97	12.24	4.05	11.92	4.13	
7	6	13.34	3.36	13.02	3.43	12.70	3.50	12.38	3.57	12.07	3.64	
10	8	13.74	3.19	13.42	3.26	13.09	3.33	12.76	3.39	12.43	3.46	
15	10	12.26	2.55	11.97	2.60	11.67	2.65	11.38	2.71	11.09	2.75	
20	15	12.28	2.26	11.99	2.31	11.69	2.36	11.40	2.40	11.11	2.44	
24	18	12.80	2.28	12.49	2.32	12.19	2.37	11.88	2.42	11.58	2.46	

Model: AUXG45LRLB

AFR	m ³ /h	2,000
-----	-------------------	-------

		Indoor temperature										
Outdoor temperature	°CDB	°CWB	16		18		20		22		24	
			TC	IP	TC	IP	TC	IP	TC	IP	TC	IP
	kW		kW		kW		kW		kW		kW	
	-15	-16	10.90	4.14	10.64	4.22	10.38	4.31	10.12	4.40	9.86	4.48
-10	-11	11.86	4.29	11.57	4.38	11.29	4.47	11.01	4.56	10.73	4.65	
-5	-7	12.96	4.25	12.65	4.34	12.34	4.43	12.03	4.43	11.73	4.43	
0	-2	14.01	4.25	13.68	4.34	13.35	4.43	13.01	4.43	12.68	4.43	
5	3	15.51	4.25	15.14	4.34	14.77	4.43	14.40	4.43	14.03	4.43	
7	6	17.01	4.25	16.61	4.34	16.20	4.43	15.80	4.43	15.39	4.43	
10	8	17.29	4.25	16.88	4.34	16.46	4.43	16.05	4.43	15.64	4.43	
15	10	16.80	3.80	16.40	3.88	16.00	3.96	15.60	3.96	15.20	3.96	
20	15	16.27	3.80	15.88	3.88	15.49	3.96	15.10	3.96	14.72	3.96	
24	18	16.79	3.26	16.39	3.33	15.99	3.40	15.60	3.40	15.20	3.40	

Model: AUXG54LRLB

AFR	m ³ /h	2,100
-----	-------------------	-------

		Indoor temperature										
Outdoor temperature	°CDB	°CWB	16		18		20		22		24	
			TC	IP	TC	IP	TC	IP	TC	IP	TC	IP
	kW		kW		kW		kW		kW		kW	
	-15	-16	11.00	4.16	10.73	4.24	10.47	4.33	10.21	4.42	9.95	4.50
-10	-11	12.08	4.31	11.79	4.40	11.50	4.49	11.22	4.58	10.93	4.67	
-5	-7	13.30	4.49	12.99	4.59	12.67	4.68	12.35	4.68	12.04	4.68	
0	-2	14.44	4.49	14.10	4.59	13.75	4.68	13.41	4.68	13.07	4.68	
5	3	16.01	4.49	15.62	4.59	15.24	4.68	14.86	4.68	14.48	4.68	
7	6	17.33	4.49	16.91	4.59	16.50	4.68	16.09	4.68	15.68	4.68	
10	8	17.61	4.49	17.19	4.59	16.77	4.68	16.35	4.68	15.93	4.68	
15	10	16.97	3.82	16.57	3.90	16.16	3.98	15.76	3.98	15.35	3.98	
20	15	16.43	3.37	16.04	3.44	15.65	3.51	15.25	3.51	14.86	3.51	
24	18	16.96	3.37	16.56	3.44	16.15	3.51	15.75	3.51	15.35	3.51	

7. Fan performance

7-1. Air velocity distributions

● Model: AUXG18LRLB (4-way air outlet)

Measuring conditions	Fan speed	Operation mode
	HIGH	FAN

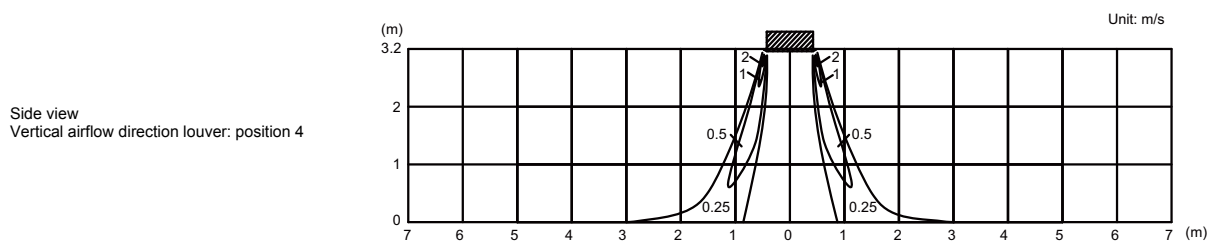
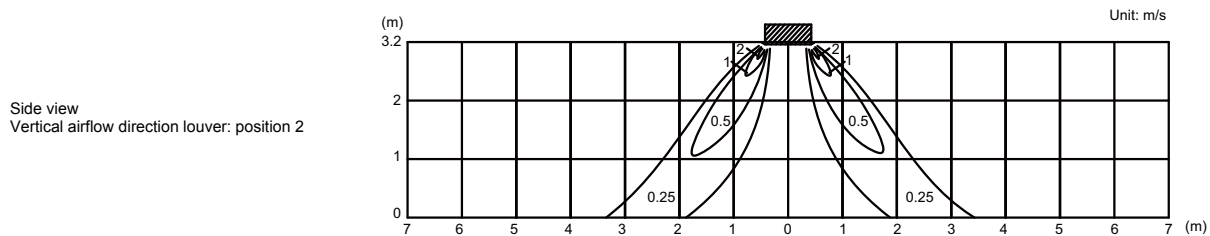
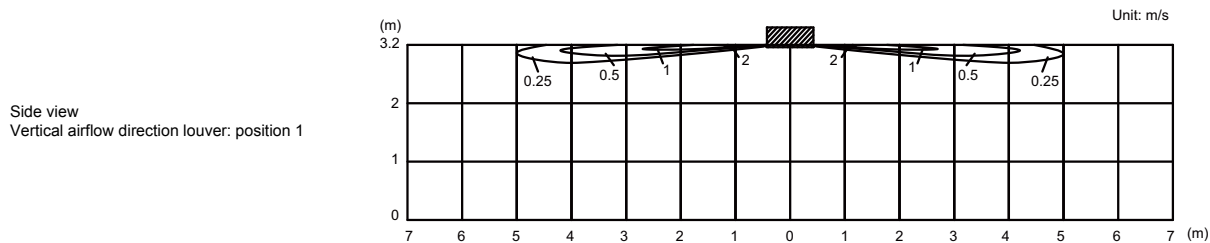
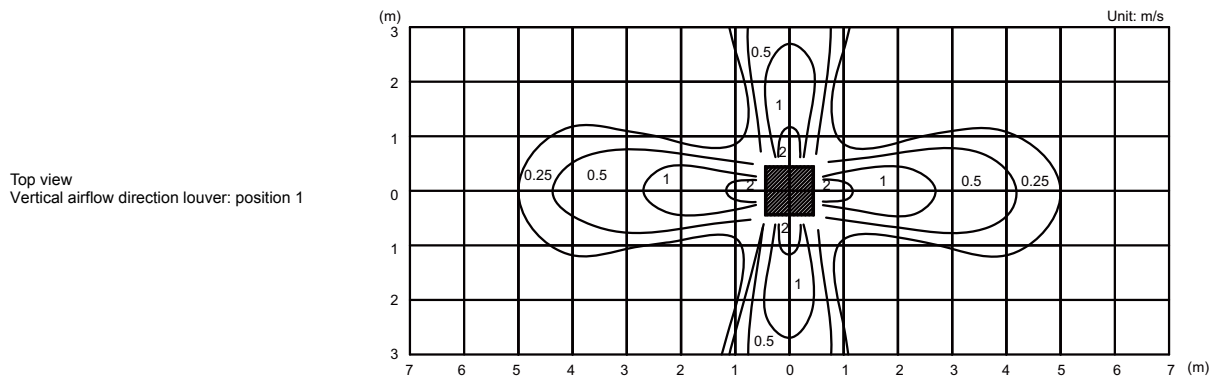

● Model: AUXG24LRLB (4-way air outlet)

Measuring conditions	Fan speed	Operation mode
	HIGH	FAN

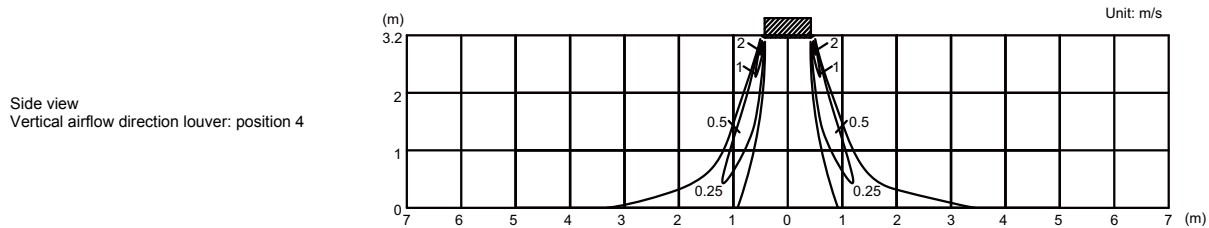
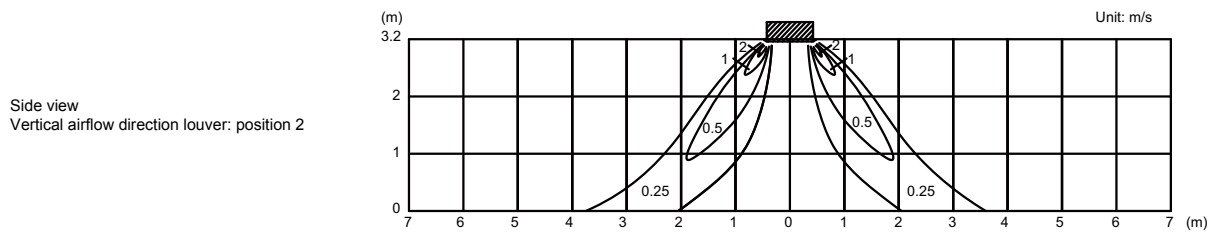
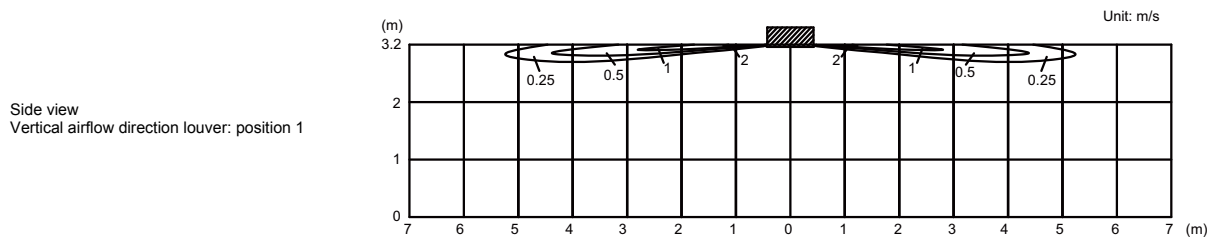
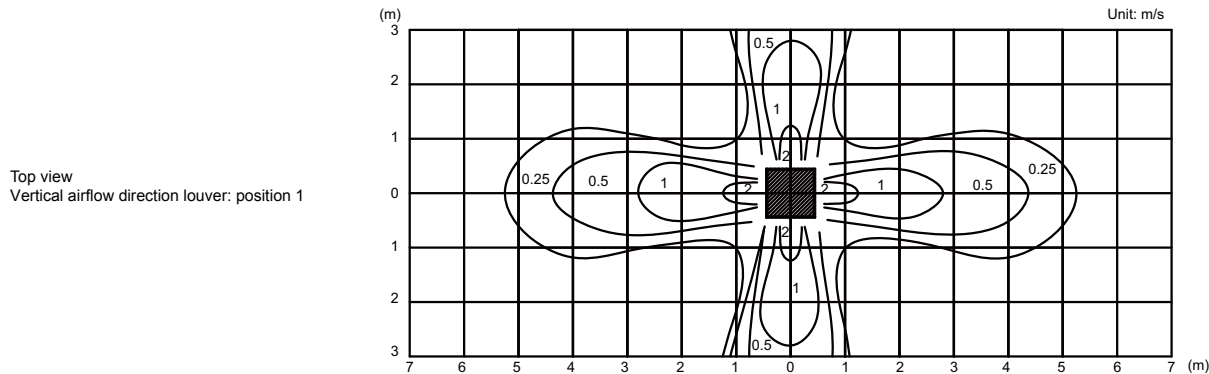

● Model: AUXG30LRLB (4-way air outlet)

Measuring conditions	Fan speed	Operation mode
	HIGH	FAN

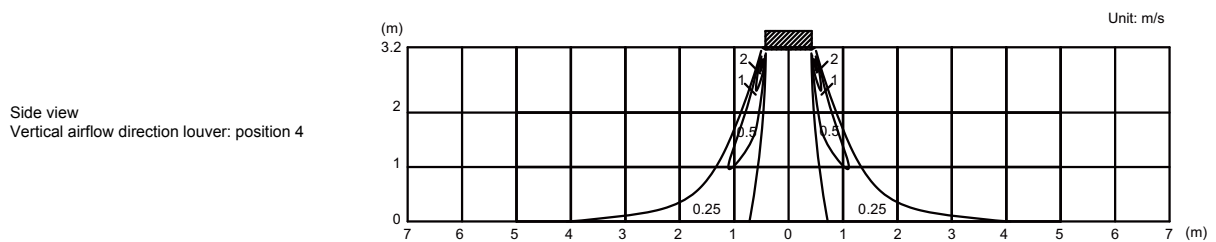
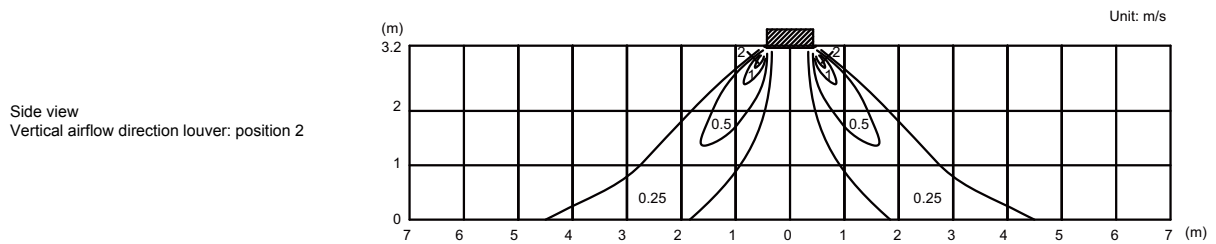
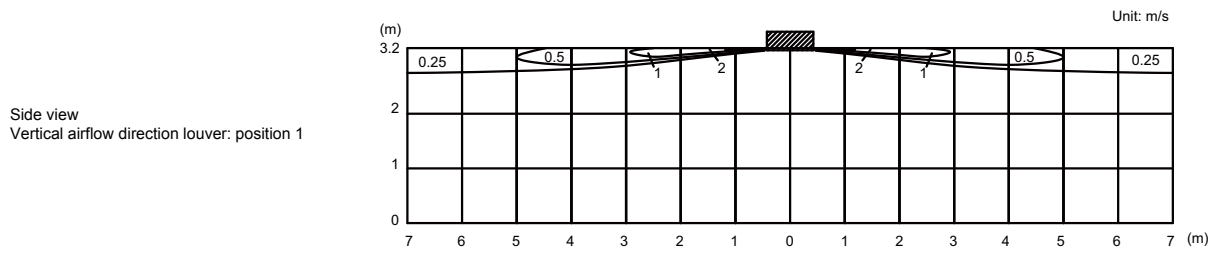
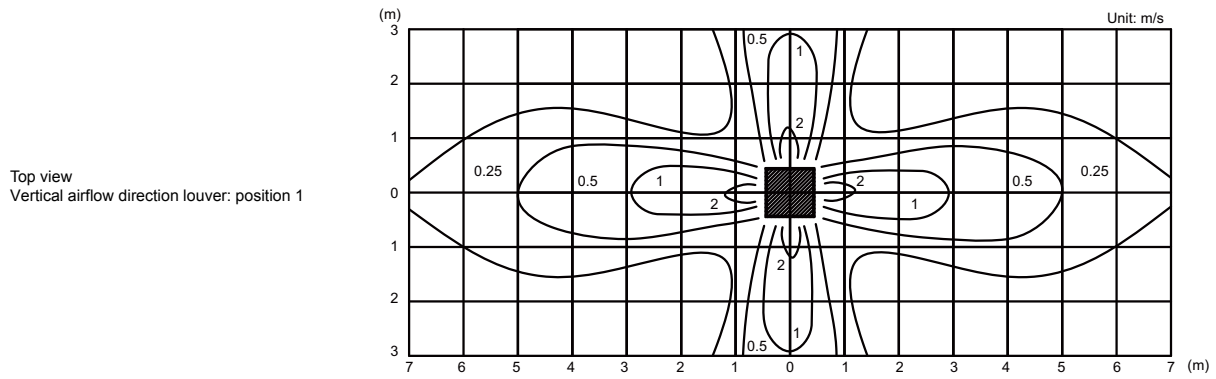

● Model: AUXG36LRLB (4-way air outlet)

Measuring conditions	Fan speed	Operation mode
	HIGH	FAN

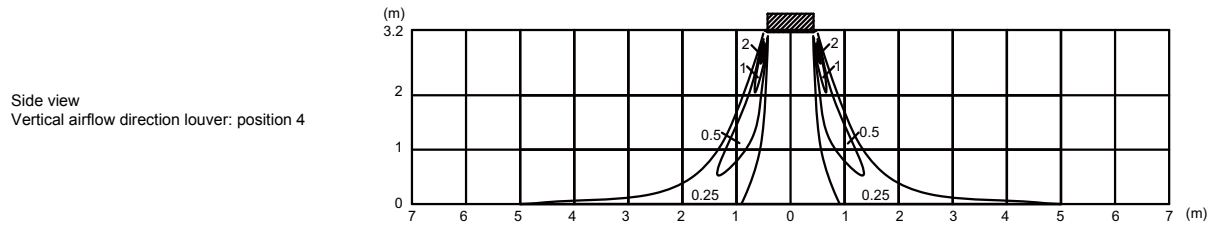
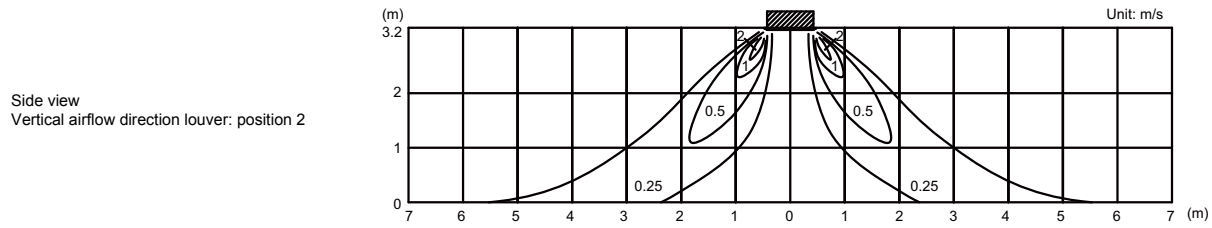
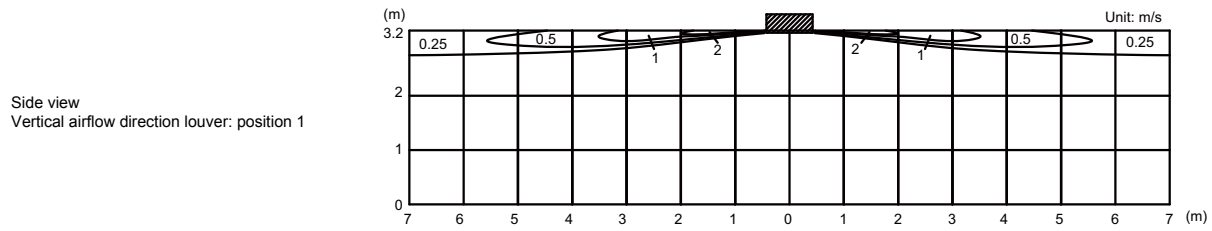
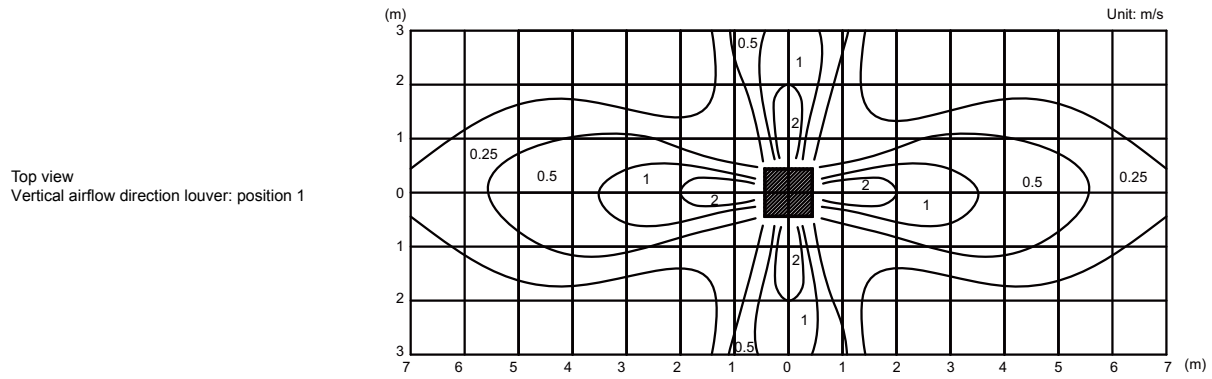

● Model: AUXG45LRLB (4-way air outlet)

Measuring conditions	Fan speed	Operation mode
	HIGH	FAN

Top view
Vertical airflow direction louver: position 1

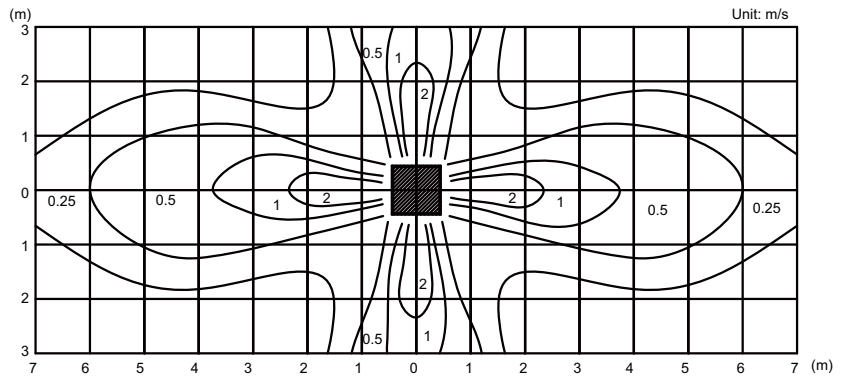

Side view
Vertical airflow direction louver: position 1

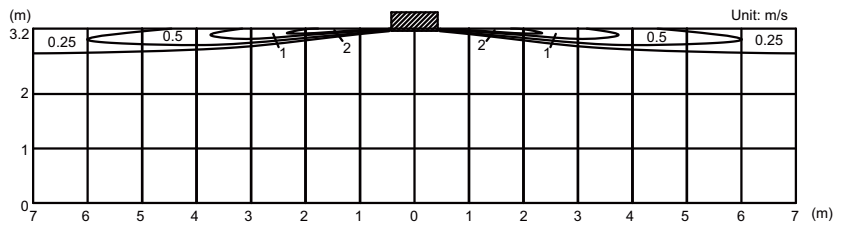

Side view
Vertical airflow direction louver: position 2

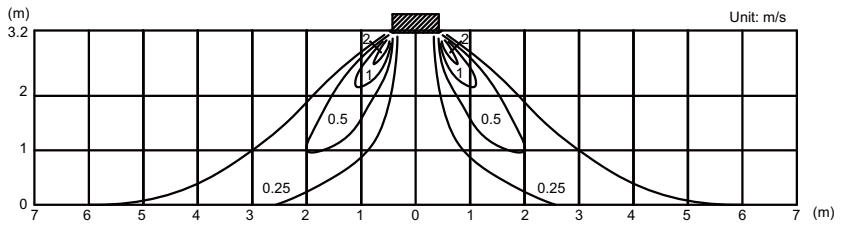

Side view
Vertical airflow direction louver: position 4

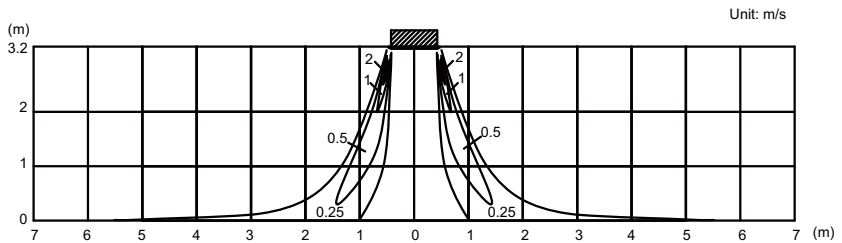

● Model: AUXG54LRLB (4-way air outlet)

Measuring conditions	Fan speed	Operation mode
	HIGH	FAN

Top view
Vertical airflow direction louver: position 1

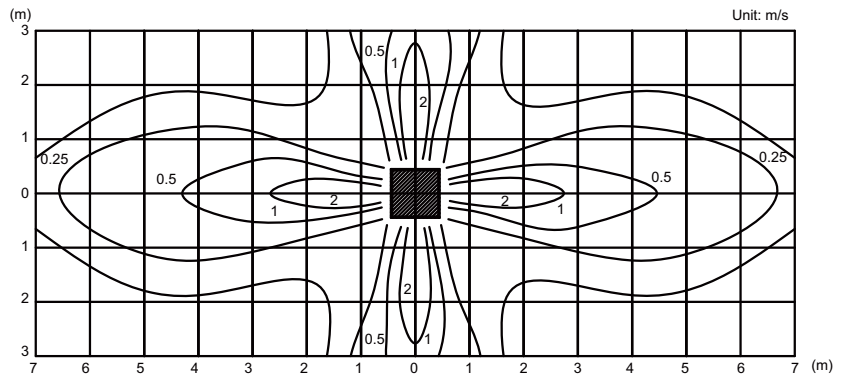

Side view
Vertical airflow direction louver: position 1

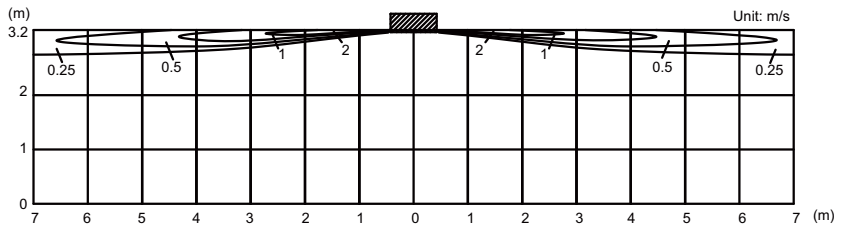

Side view
Vertical airflow direction louver: position 2

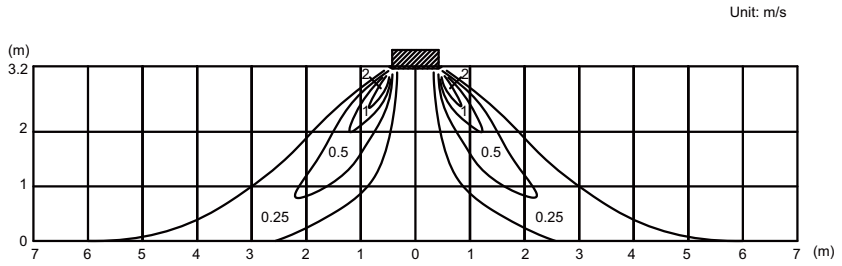

Side view
Vertical airflow direction louver: position 4

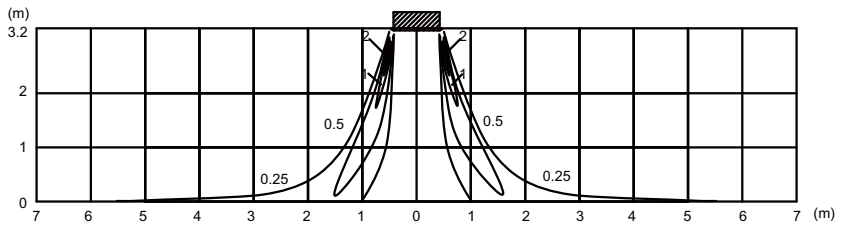

● Model: AUXG18LRLB (3-way air outlet)

Measuring conditions	Fan speed	Operation mode
	HIGH	FAN

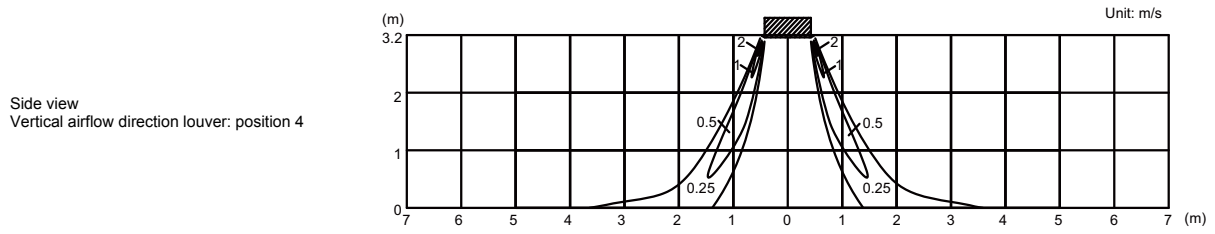
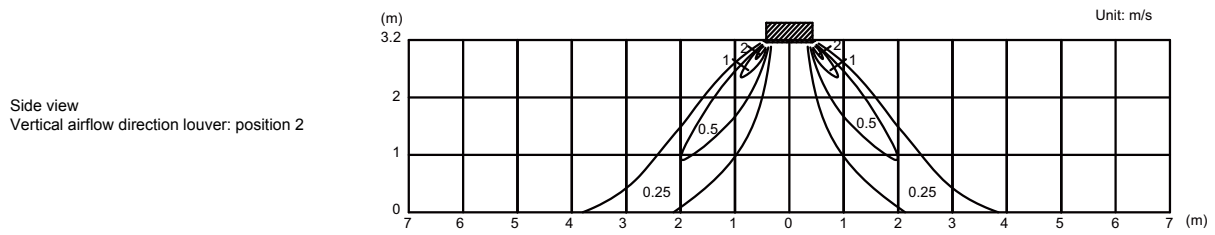
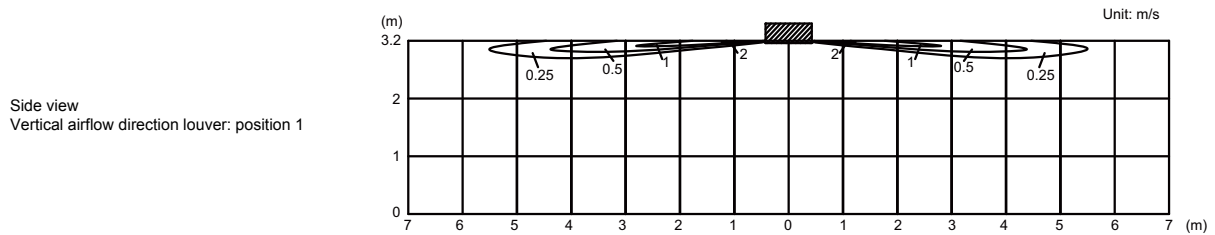
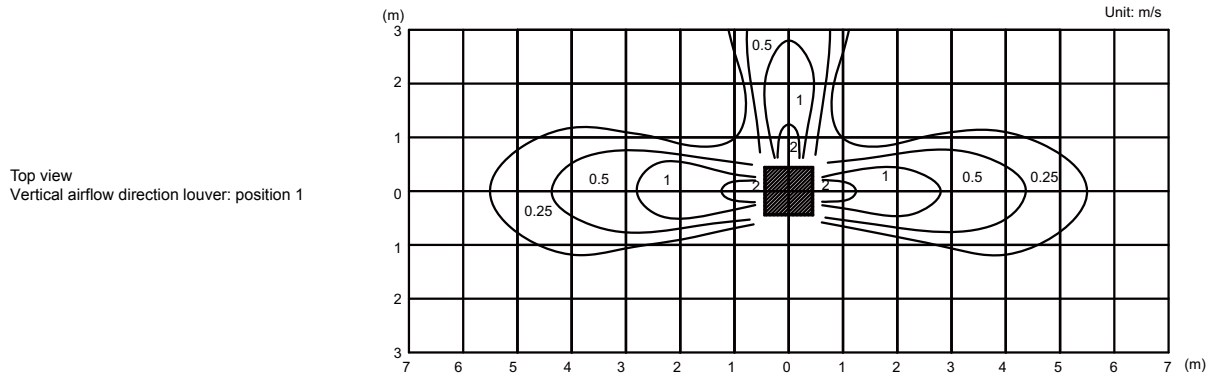

● Model: AUXG24LRLB (3-way air outlet)

Measuring conditions	Fan speed	Operation mode
	HIGH	FAN

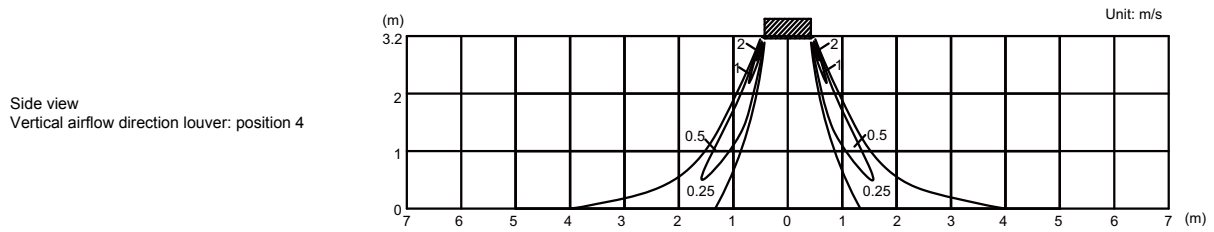
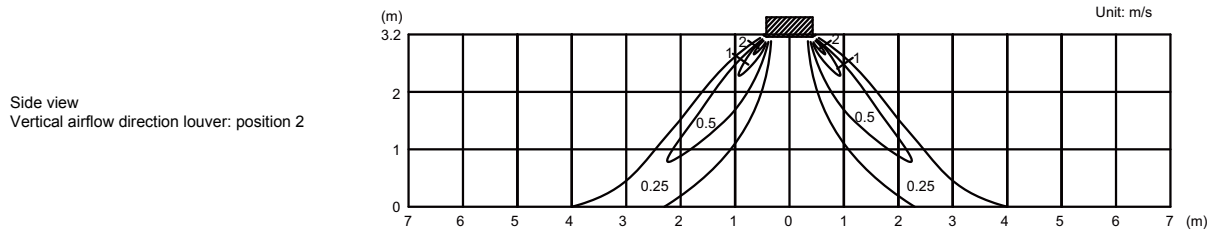
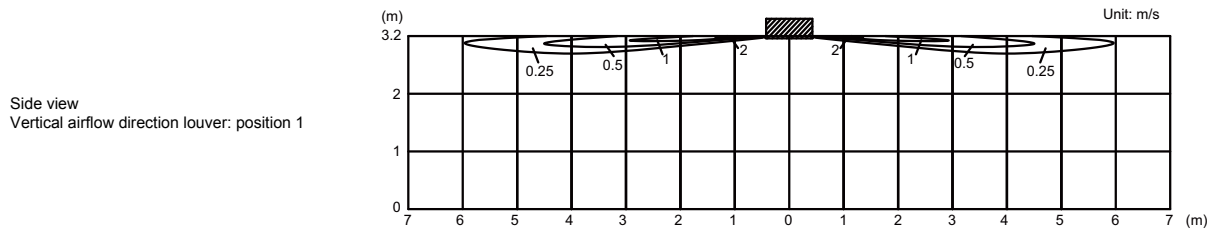
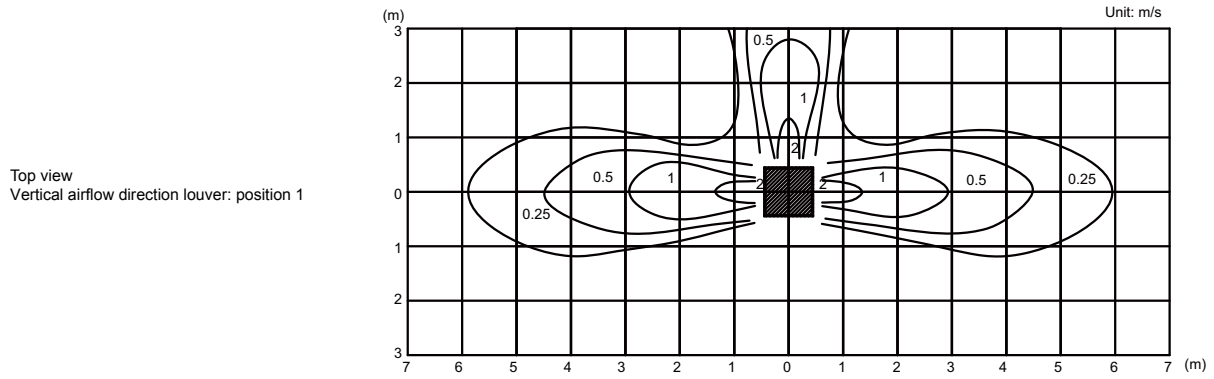

● Model: AUXG30LRLB (3-way air outlet)

Measuring conditions	Fan speed	Operation mode
	HIGH	FAN

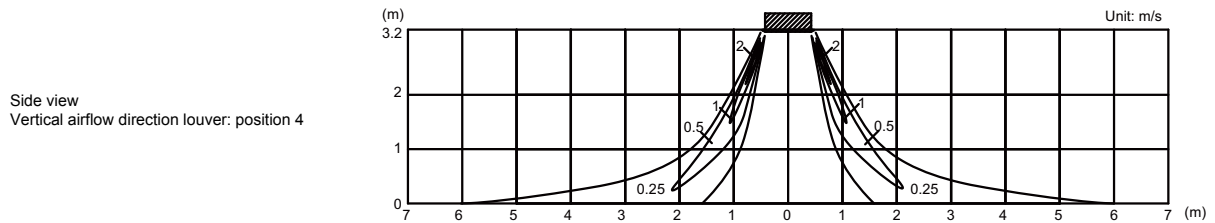
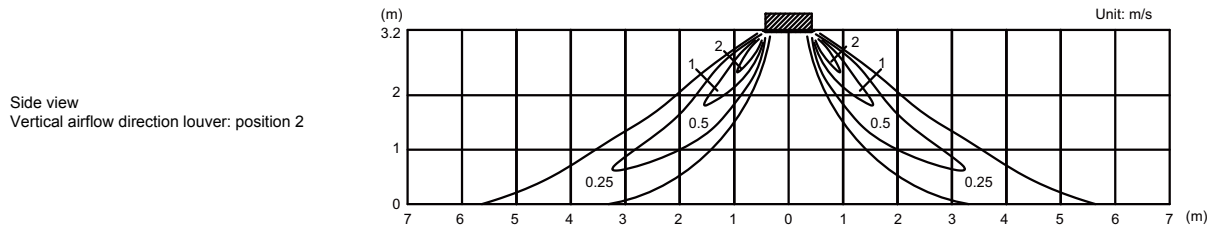
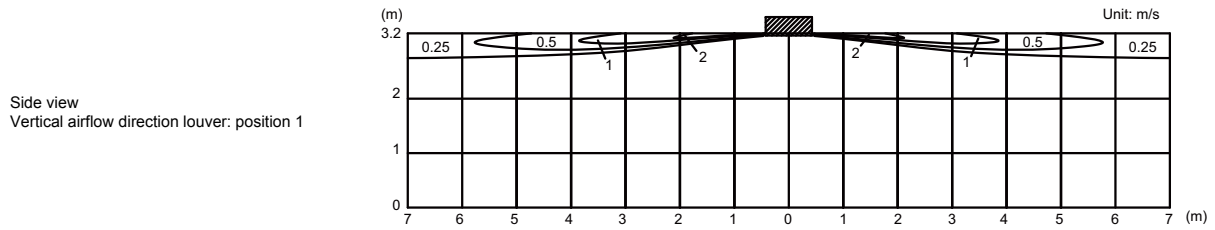
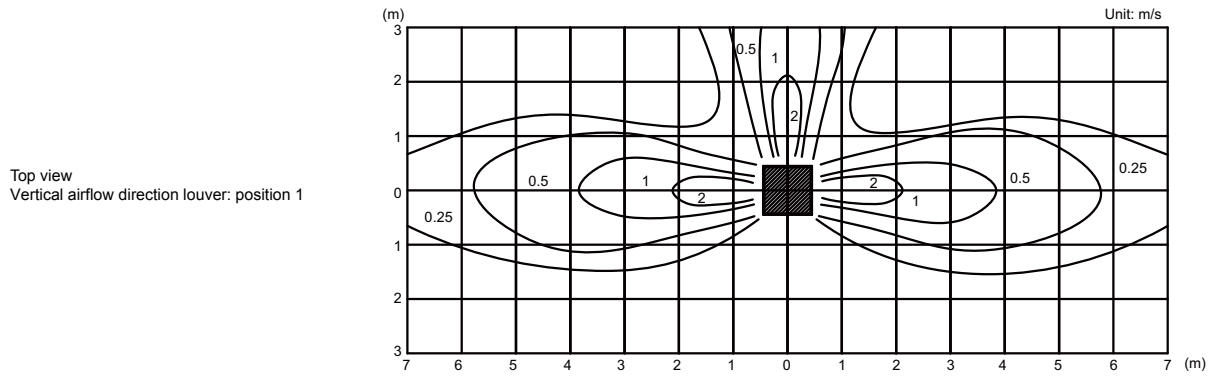

● Model: AUXG36LRLB (3-way air outlet)

Measuring conditions	Fan speed	Operation mode
	HIGH	FAN

Top view
Vertical airflow direction louver: position 1

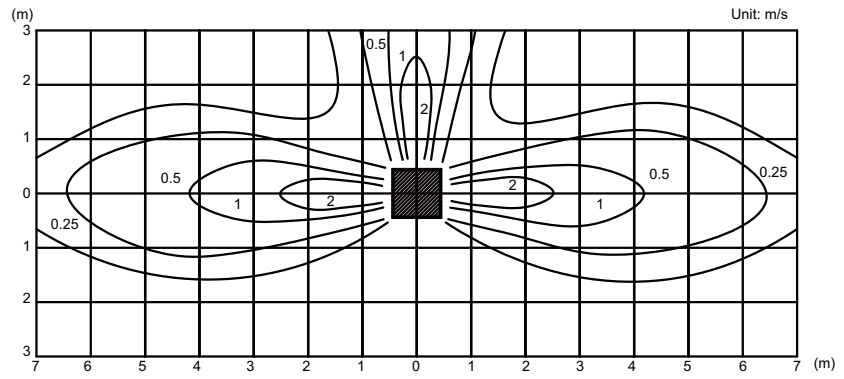

Side view
Vertical airflow direction louver: position 1

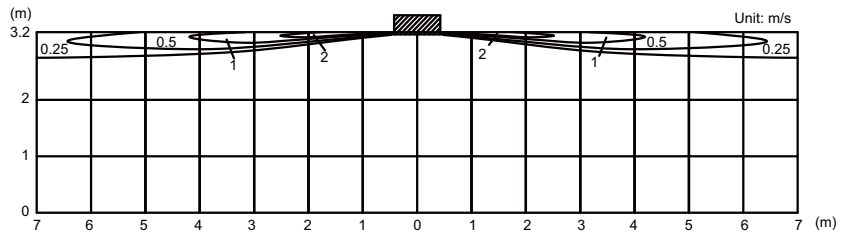

Side view
Vertical airflow direction louver: position 2

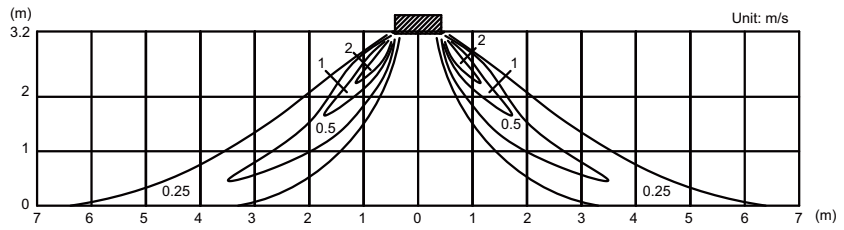

Side view
Vertical airflow direction louver: position 4

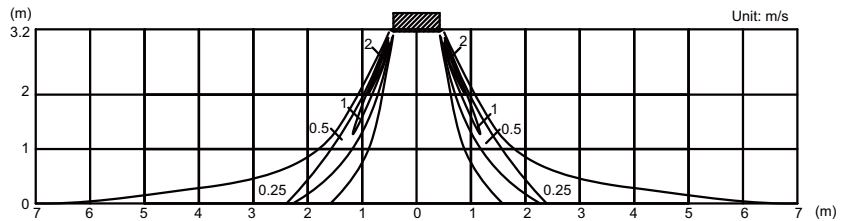

● Model: AUXG45LRLB (3-way air outlet)

Measuring conditions	Fan speed	Operation mode
	HIGH	FAN

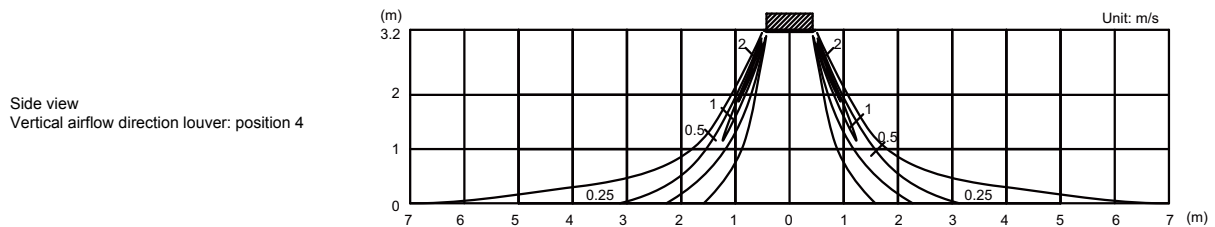
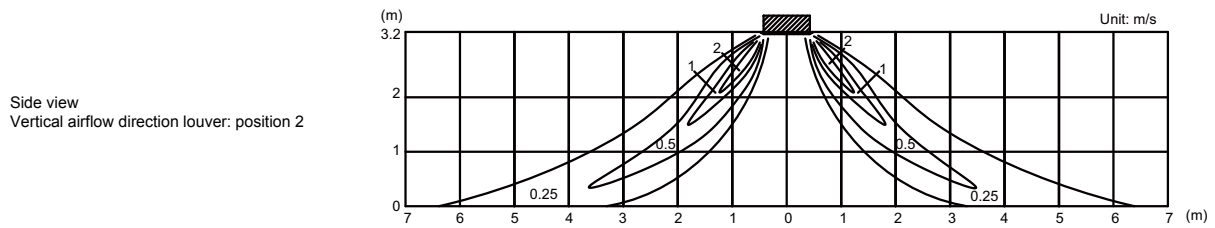
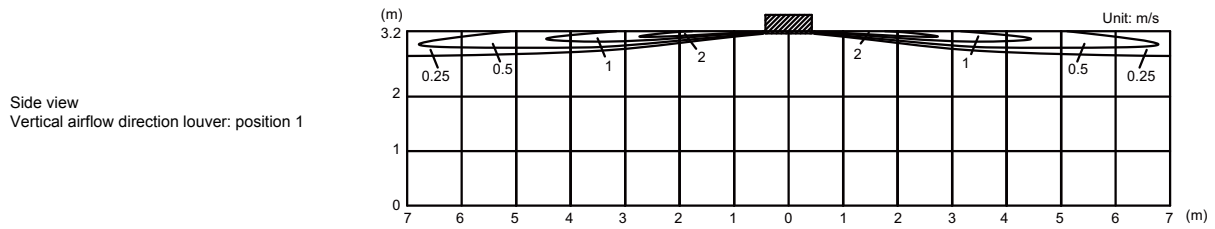
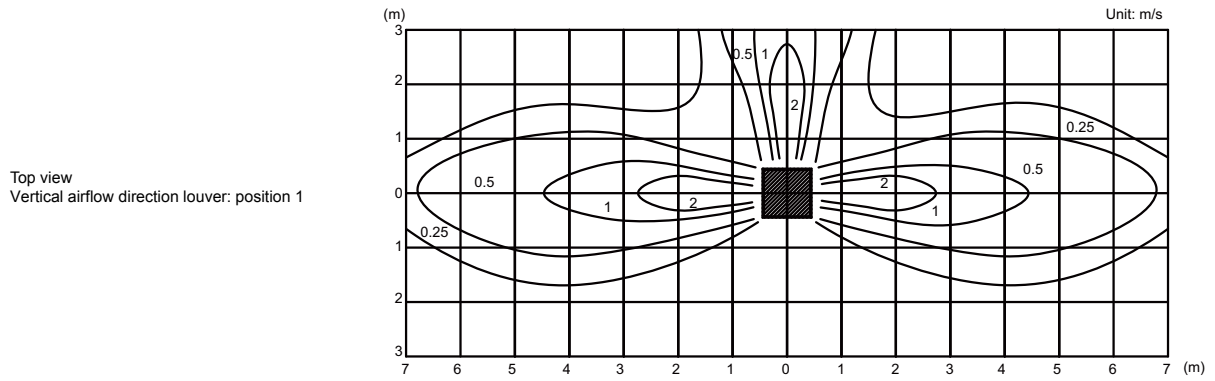

● Model: AUXG54LRLB (3-way air outlet)

Measuring conditions	Fan speed	Operation mode
	HIGH	FAN

Top view
Vertical airflow direction louver: position 1

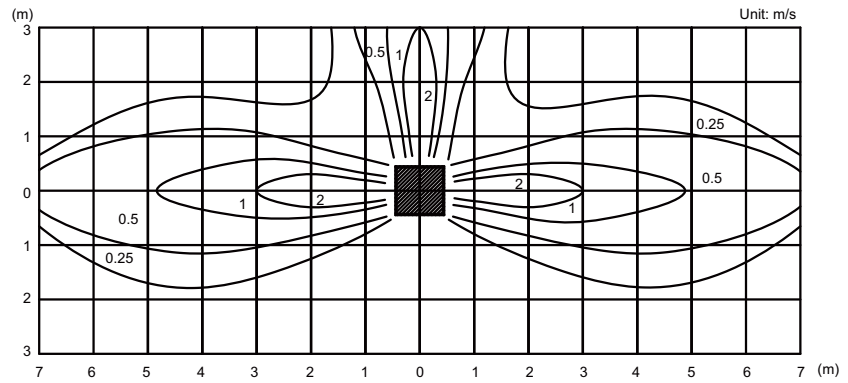

Side view
Vertical airflow direction louver: position 1

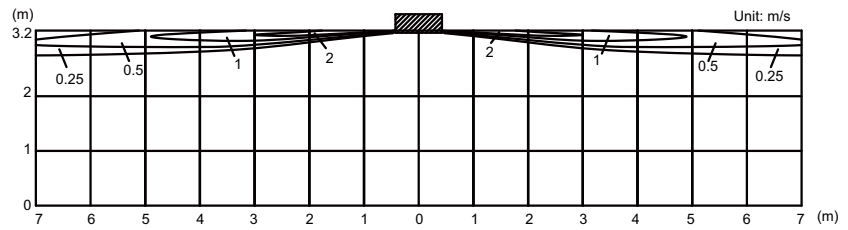

Side view
Vertical airflow direction louver: position 2

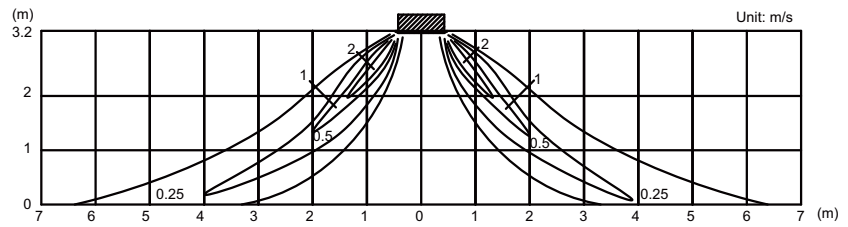

Side view
Vertical airflow direction louver: position 4

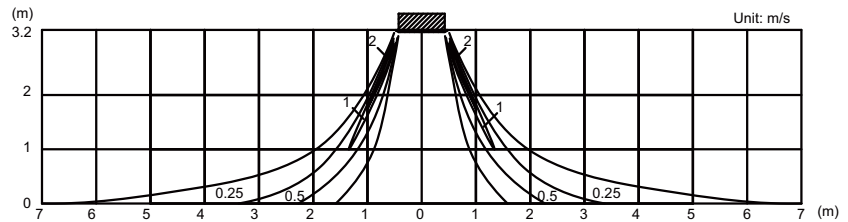

7-2. Airflow

■ Model: AUXG18LRLB (4-way outlet)

● Cooling/Heating

Fan speed	Airflow	
HIGH	m ³ /h	1,050
	l/s	292
	CFM	618
MED	m ³ /h	960
	l/s	267
	CFM	565
LOW	m ³ /h	900
	l/s	250
	CFM	530
QUIET	m ³ /h	780
	l/s	217
	CFM	459

■ Model: AUXG24LRLB (4-way outlet)

● Cooling/Heating

Fan speed	Airflow	
HIGH	m ³ /h	1,150
	l/s	319
	CFM	677
MED	m ³ /h	1,050
	l/s	292
	CFM	618
LOW	m ³ /h	980
	l/s	272
	CFM	577
QUIET	m ³ /h	870
	l/s	242
	CFM	512

■ Model: AUXG30LRLB (4-way outlet)

● Cooling/Heating

Fan speed	Airflow	
HIGH	m ³ /h	1,600
	l/s	444
	CFM	942
MED	m ³ /h	1,400
	l/s	389
	CFM	824
LOW	m ³ /h	1,270
	l/s	353
	CFM	748
QUIET	m ³ /h	1,150
	l/s	319
	CFM	677

■ Model: AUXG36LRLB (4-way outlet)

● Cooling/Heating

Fan speed	Airflow	
HIGH	m ³ /h	1,900
	l/s	528
	CFM	1,118
MED	m ³ /h	1,590
	l/s	442
	CFM	936
LOW	m ³ /h	1,420
	l/s	394
	CFM	836
QUIET	m ³ /h	1,180
	l/s	328
	CFM	695

■ Model: AUXG45LRLB (4-way outlet)

● Cooling/Heating

Fan speed	Airflow	
HIGH	m ³ /h	2,000
	l/s	556
	CFM	1,177
MED	m ³ /h	1,650
	l/s	458
	CFM	971
LOW	m ³ /h	1,460
	l/s	406
	CFM	859
QUIET	m ³ /h	1,300
	l/s	361
	CFM	765

■ Model: AUXG54LRLB (4-way outlet)

● Cooling/Heating

Fan speed	Airflow	
HIGH	m ³ /h	2,100
	l/s	583
	CFM	1,236
MED	m ³ /h	1,780
	l/s	494
	CFM	1,048
LOW	m ³ /h	1,600
	l/s	444
	CFM	942
QUIET	m ³ /h	1,320
	l/s	367
	CFM	777

■ Model: AUXG18LRLB (3-way outlet)

● Cooling/Heating

Fan speed	Airflow	
HIGH	m ³ /h	915
	l/s	254
	CFM	539
MED	m ³ /h	835
	l/s	232
	CFM	491
LOW	m ³ /h	785
	l/s	218
	CFM	462
QUIET	m ³ /h	680
	l/s	189
	CFM	400

■ Model: AUXG24LRLB (3-way outlet)

● Cooling/Heating

Fan speed	Airflow	
HIGH	m ³ /h	1,000
	l/s	278
	CFM	589
MED	m ³ /h	915
	l/s	254
	CFM	538
LOW	m ³ /h	850
	l/s	236
	CFM	500
QUIET	m ³ /h	755
	l/s	210
	CFM	445

■ **Model: AUXG30LRLB (3-way outlet)**

● **Cooling/Heating**

Fan speed	Airflow	
HIGH	m ³ /h	1,390
	l/s	386
	CFM	818
MED	m ³ /h	1,220
	l/s	339
	CFM	719
LOW	m ³ /h	1,100
	l/s	306
	CFM	648
QUIET	m ³ /h	1,000
	l/s	278
	CFM	589

■ **Model: AUXG36LRLB (3-way outlet)**

● **Cooling/Heating**

Fan speed	Airflow	
HIGH	m ³ /h	1,660
	l/s	461
	CFM	978
MED	m ³ /h	1,390
	l/s	386
	CFM	819
LOW	m ³ /h	1,240
	l/s	344
	CFM	730
QUIET	m ³ /h	1,030
	l/s	286
	CFM	607

■ **Model: AUXG45LRLB (3-way outlet)**

● **Cooling/Heating**

Fan speed	Airflow	
HIGH	m ³ /h	1,740
	l/s	483
	CFM	1,025
MED	m ³ /h	1,440
	l/s	400
	CFM	848
LOW	m ³ /h	1,270
	l/s	353
	CFM	748
QUIET	m ³ /h	1,130
	l/s	314
	CFM	666

■ Model: AUXG54LRLB (3-way outlet)

● Cooling/Heating

Fan speed	Airflow	
HIGH	m ³ /h	1,830
	l/s	508
	CFM	1,078
MED	m ³ /h	1,550
	l/s	431
	CFM	913
LOW	m ³ /h	1,390
	l/s	386
	CFM	819
QUIET	m ³ /h	1,150
	l/s	319
	CFM	677

7-3. Fresh-air characteristics

■ Airflow volume: static pressure of fresh-air intake characteristics

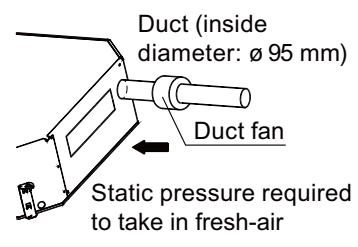
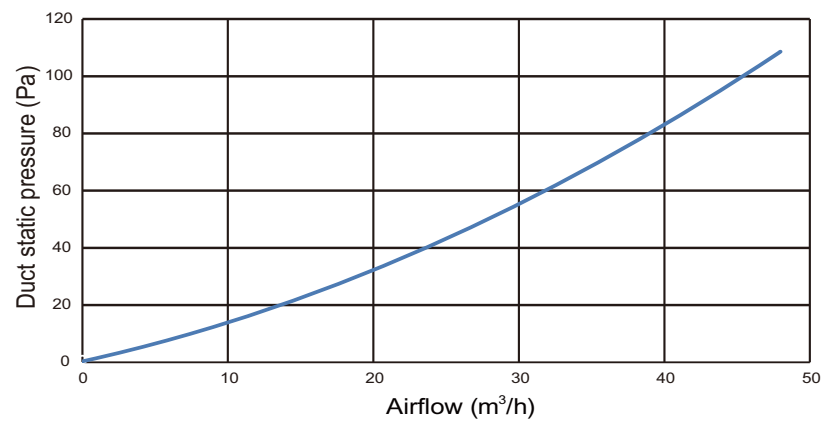

■ Installation

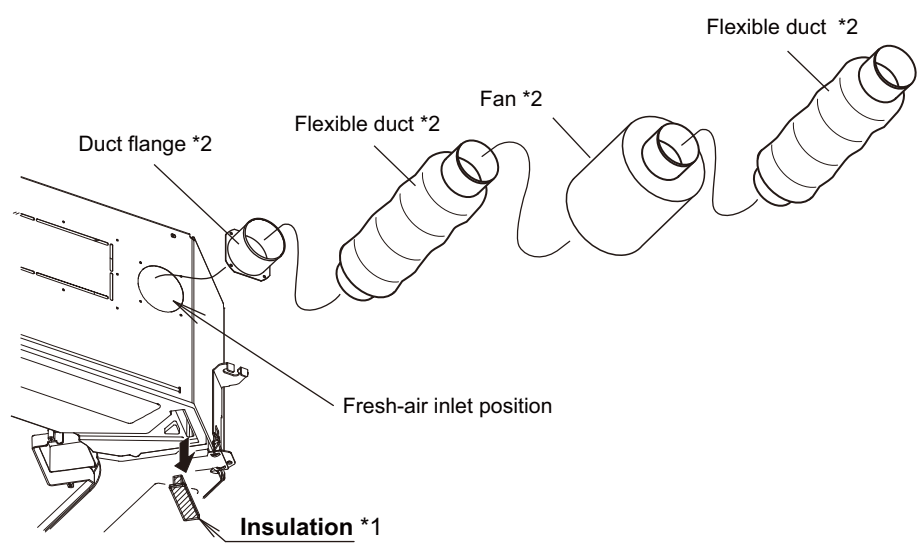
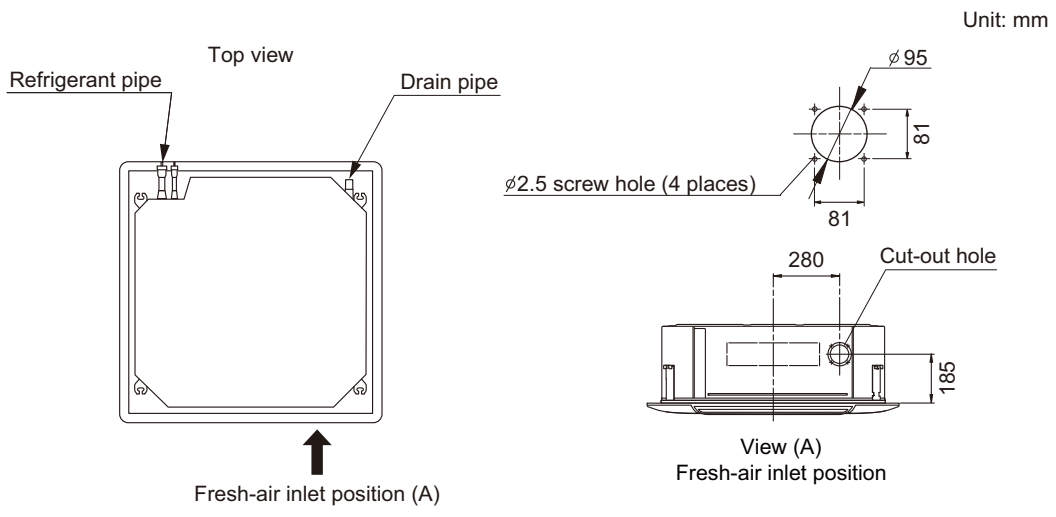

*1: In case of fresh-air intake, remove the insulation.
*2: Locally-purchased parts

7-4. Duct connection

■ Outlet air

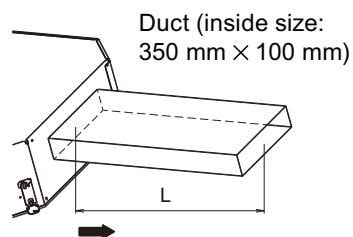

● Model: AUXG18LRLB

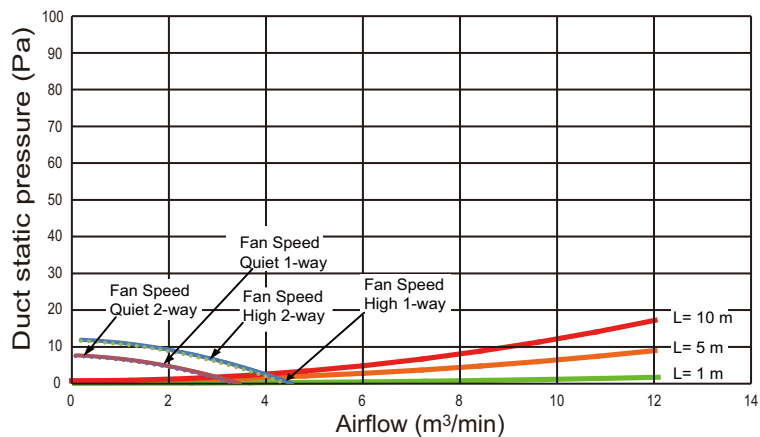

● Model: AUXG24LRLB

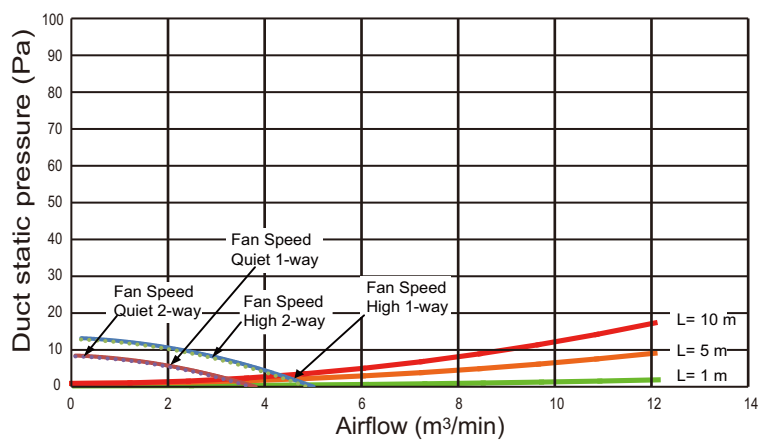

● Model: AUXG30LRLB

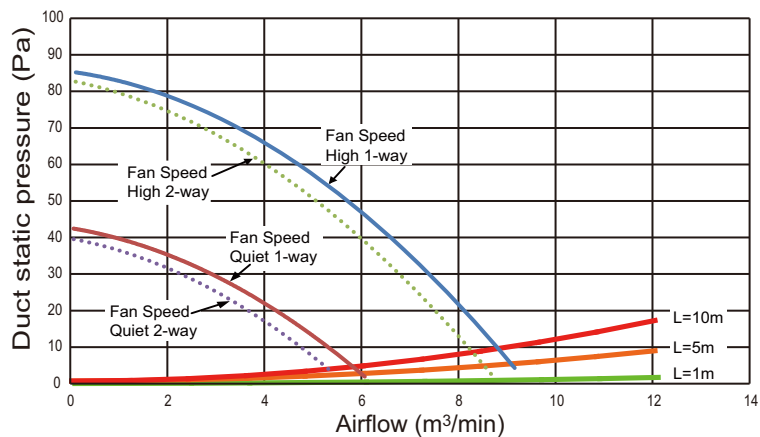

● Model: AUXG36LRLB

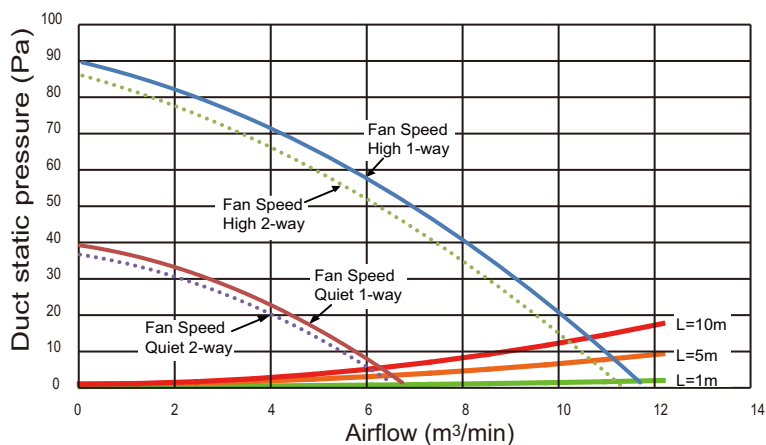

● Model: AUXG45LRLB

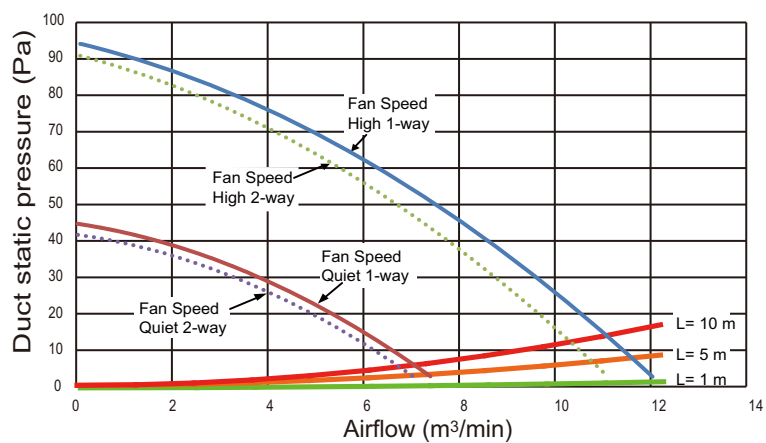

● Model: AUXG54LRLB

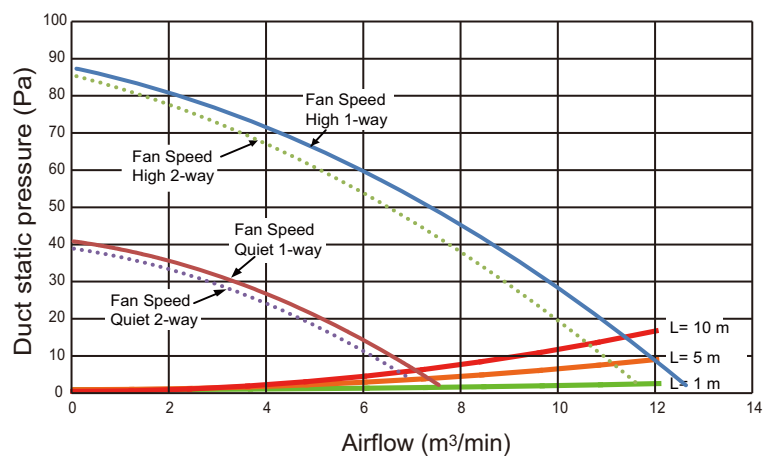

■ Precautions on air-outlet duct connection

- Connect the air-outlet duct to maximum 2 directions among the 4-duct connecting directions.

⚠ CAUTION

Do not connect ducts at 3 or more directions.

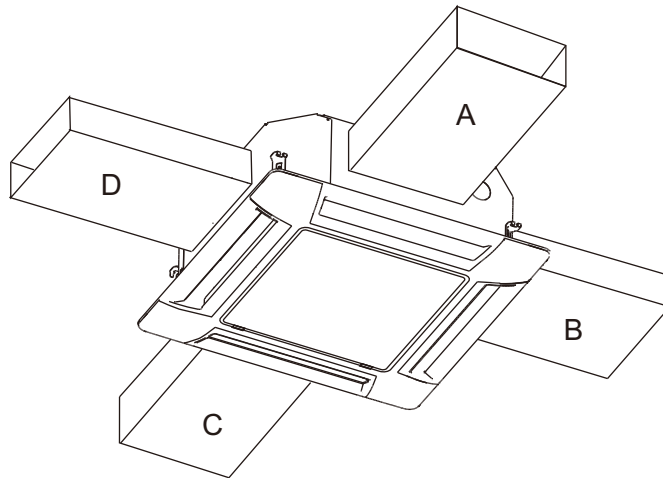

- When installing air-outlet duct in 2 directions, connect the ducts in a straight line.

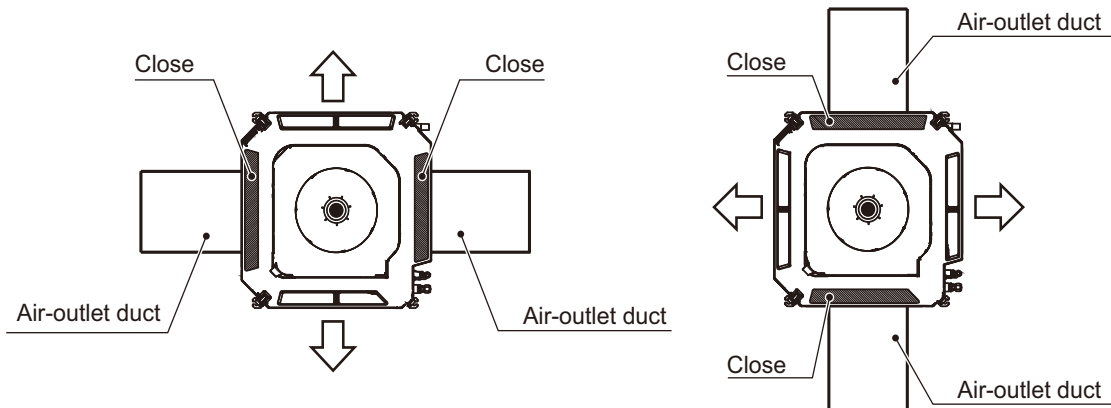

- Once the ducted direction is decided, be sure to close the outlet in the direction. Use optional Air outlet shutter plate (UTR-YDZK) to close the outlet.

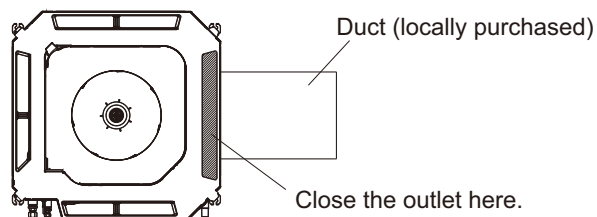

8. Operation noise (sound pressure)

8-1. Noise level curve

Measuring conditions	Ceiling height	Outlet directions
	Standard	4-way air outlet

Model: AUXG18LRLB

● Cooling

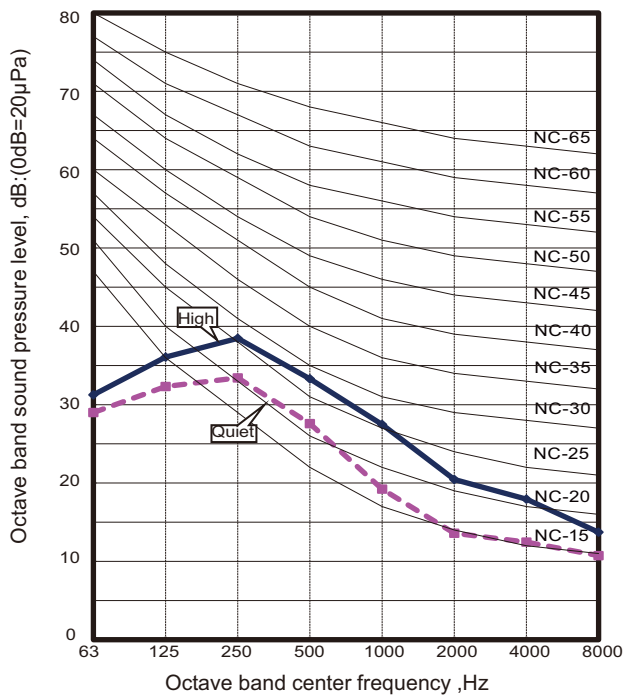

● Heating

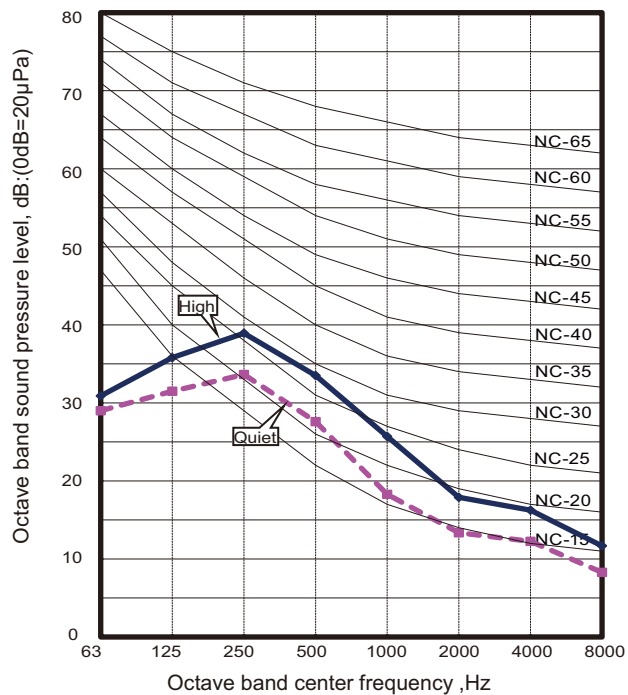

Model: AUXG24LRLB

● Cooling

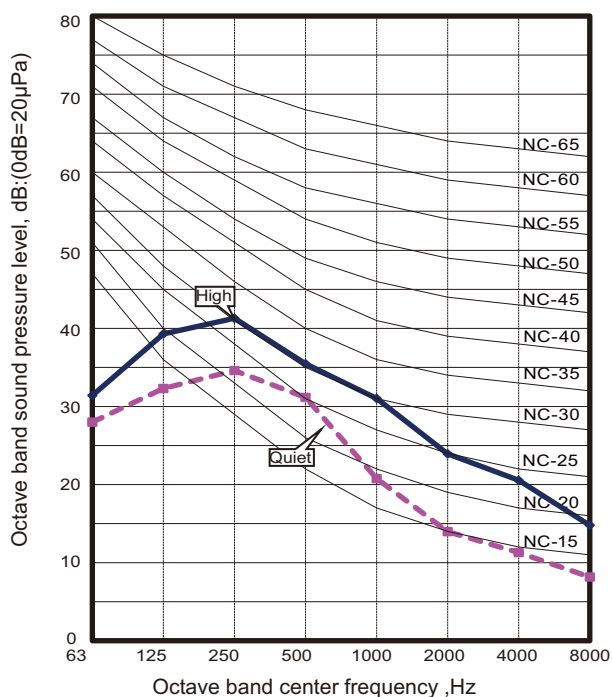

● Heating

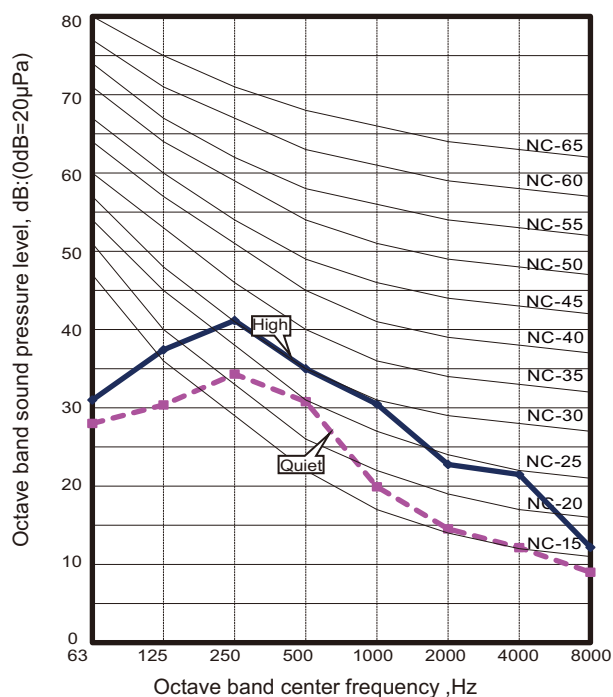

Model: AUXG30LRLB

Cooling

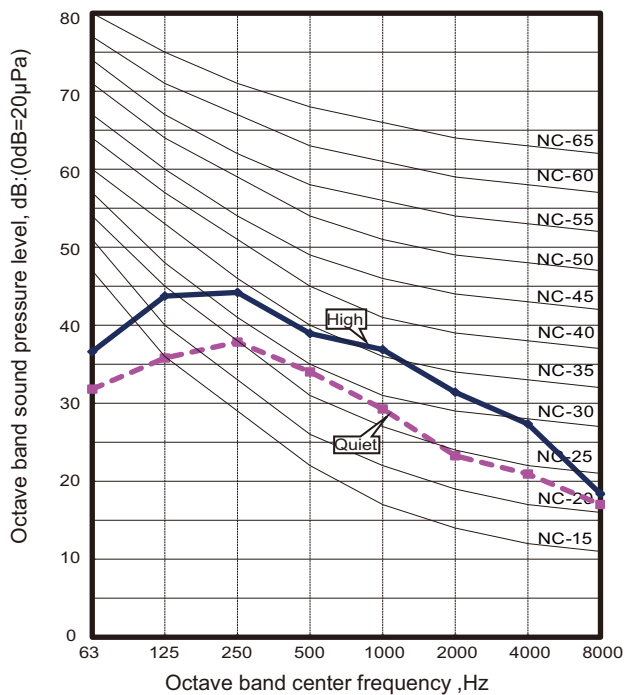

Heating

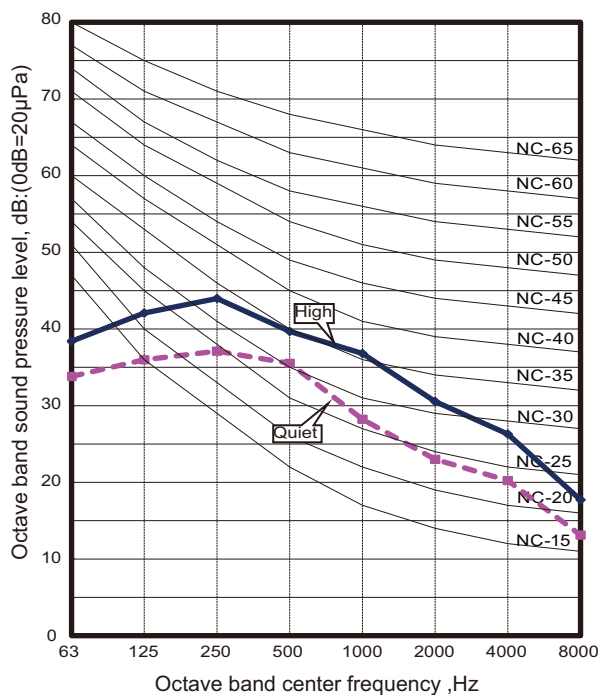

Model: AUXG36LRLB

Cooling

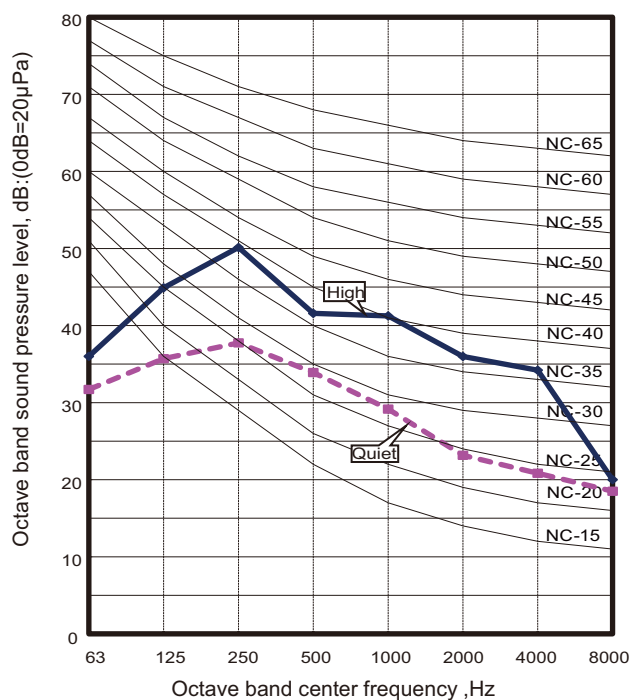

Heating

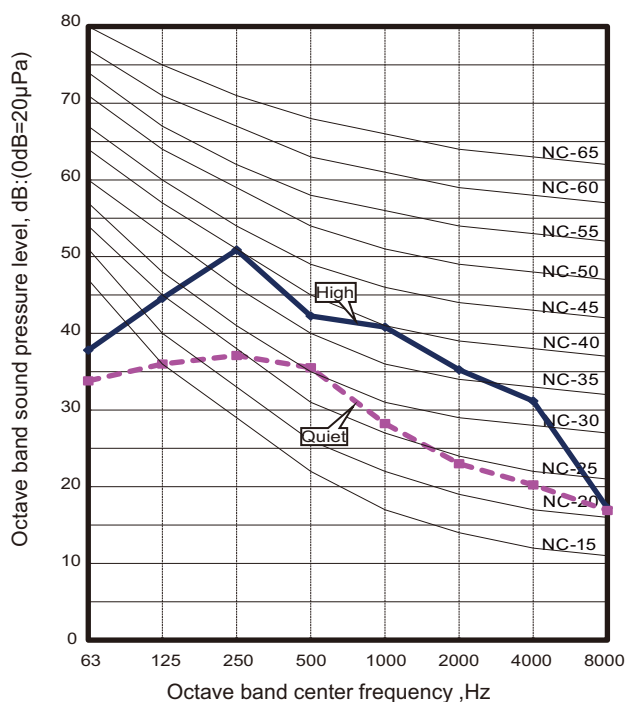

Model: AUXG45LRB

Cooling

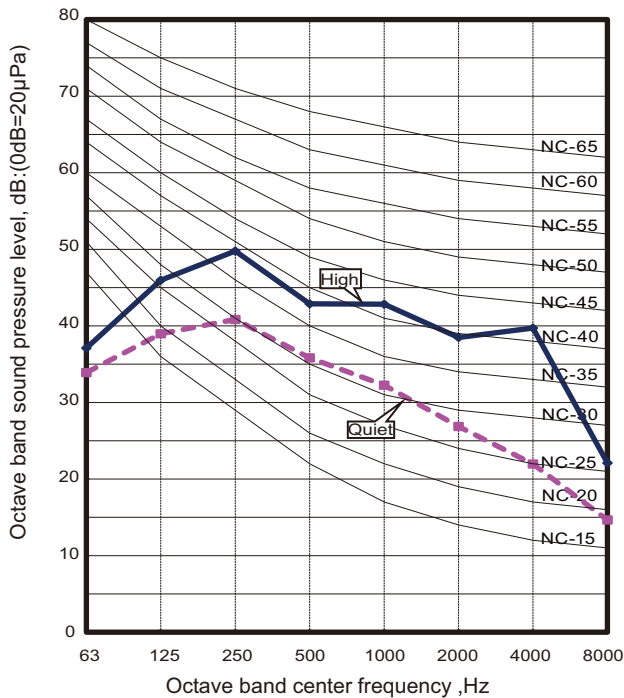

Heating

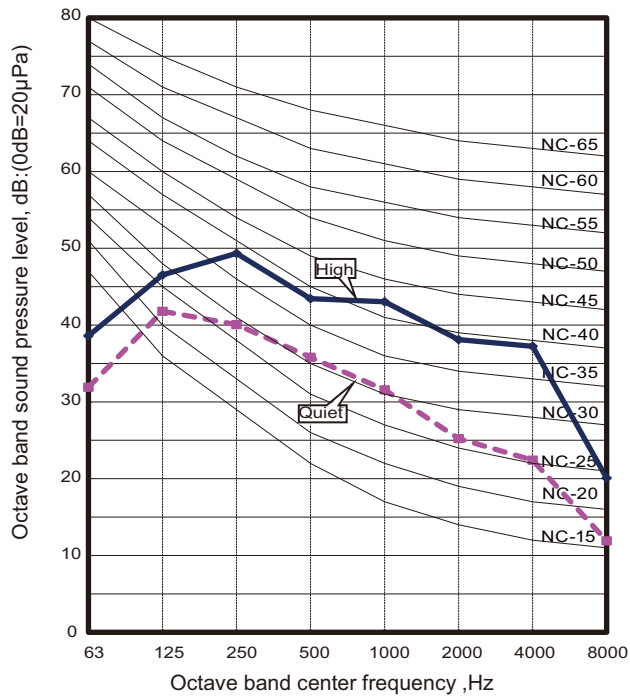

Model: AUXG54LRB

Cooling

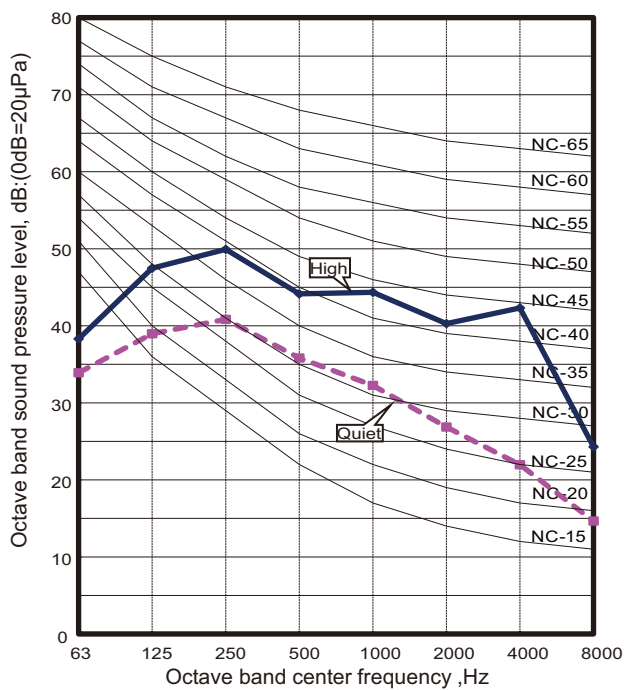

Heating

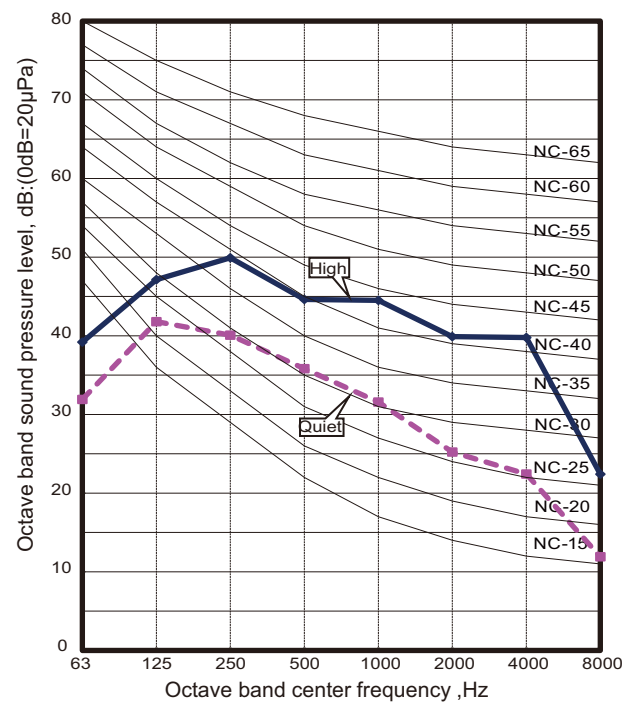

8-2. Sound level check point

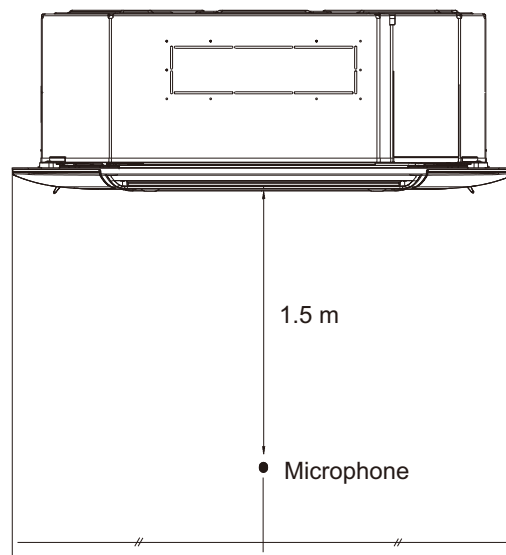
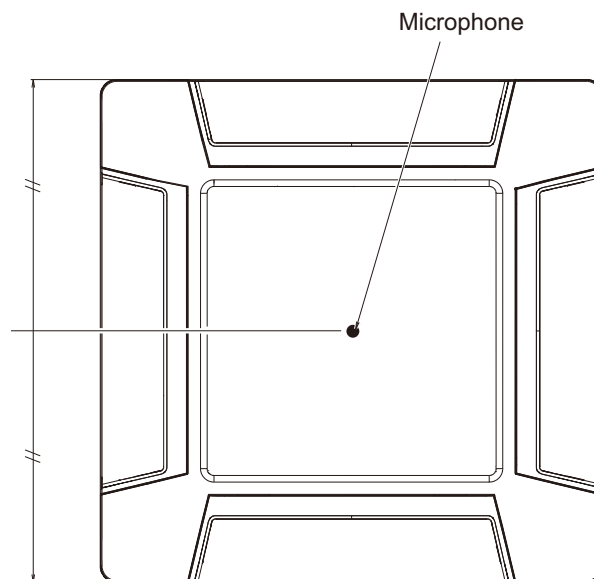

9. Safety devices

Type of protection	Protection form		Model	
			AUXG18LRLB	AUXG24LRLB
Circuit protection	Current fuse (PCB*)		250 V, 3.15 A	
Fan motor protection	Thermal protection program	Activate	125 ± 10 °C Fan motor stop	
		Reset	120 ± 10 °C Fan motor restart	

Type of protection	Protection form		Model			
			AUXG30LRLB	AUXG36LRLB	AUXG45LRLB	AUXG54LRLB
Circuit protection	Current fuse (PCB*)		250 V, 3.15 A			
Fan motor protection	Thermal protection program	Activate	125 ± 10 °C Fan motor stop			
		Reset	120 ± 10 °C Fan motor restart			

*: Printed Circuit Board

10. External input and output

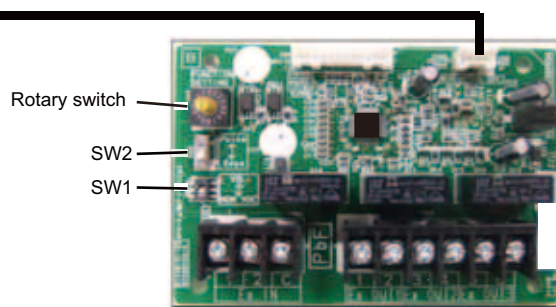
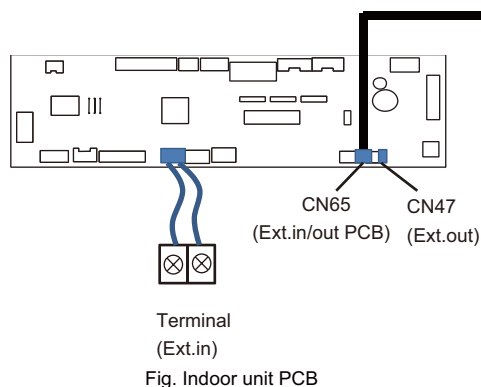

Fig. External input and output PCB

PCB	External input	External output	Connector	Input select	Input signal	External connect kit (Optional parts)
Indoor unit	Operation/Stop	-	Terminal	Dry contact	Edge	-
	-	Operation status	CN47	-	-	UTY-XWZXZG
		Error status				
		Indoor unit fan operation status				
External heater output						
External input and output (UTY-XCSX)	Operation/Stop	-	Input 1/ Input 2	Dry contact/ Apply voltage	Edge/ Pulse	-
	Forced thermostat off		Input 1		Edge	
	-	Operation status	Output 1 Output 2 Output 3	-	-	-
		Error status				
Indoor unit status						
External heater output						

10-1. External input

- “Operation/Stop” mode or “Forced stop” mode can be selected with function setting of indoor unit.
- A twisted pair cable (22AWG) should be used. Maximum length of cable is 150 m.
- The wire connection should be separate from the power cable line.

■ Indoor unit

Indoor unit functions such as Operation/Stop can be done by using indoor unit terminals.

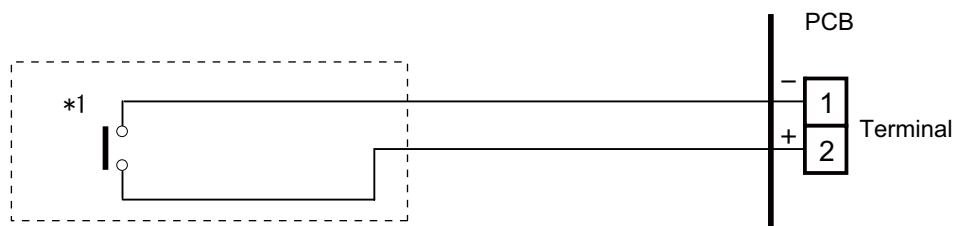

*1: The switch can be used on the following condition: DC 12 V to 24 V, 1 mA to 15 mA.

External input and output PCB

The indoor unit Operation/Stop can be set by using the input terminal on the PCB.

Input select

Use either one of these types of terminals according to the application. (Both types of terminals cannot be used simultaneously.)

- Dry contact

In case of internal power supply, set the slide switch of SW1 to "NON VOL" side.

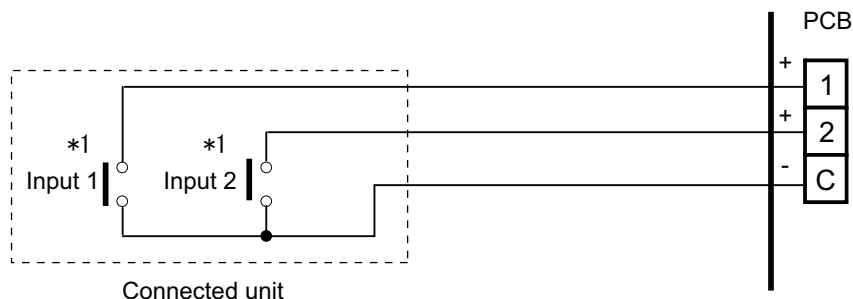

*1: The switches can be used on the following condition: DC 12 V to 24 V, 1 mA to 15 mA.

- Apply voltage

In case of external power supply, set the slide switch of SW1 to "VOL" side.

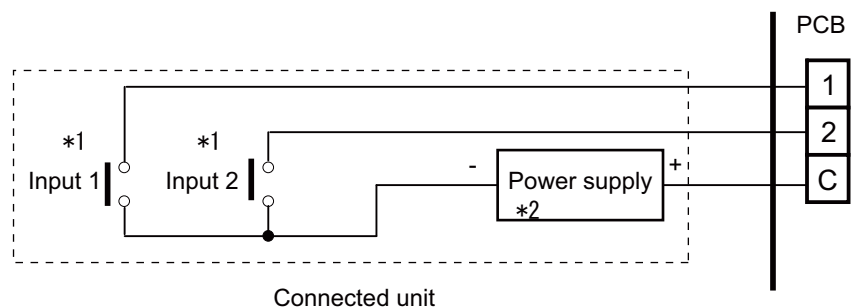

*1: The switches can be used on the following condition: DC 12 V to 24 V, 1 mA to 15 mA.

*2: Make the power supply DC 12 V to 24 V 10 mA or more.

10-2. External output

Use an external output cable with appropriate external dimension, depending on the number of cables to be installed.

■ Indoor unit

- A twisted pair cable (22AWG) should be used. Maximum length of cable is 25 m.
- Output voltage: High DC 12 V \pm 2 V, Low 0 V.
- Permissible current: 50 mA
- For details, refer to Chapter 10-3. "Combination of external input and output" on page 57.

● When indicator, etc. are connected directly

Example: Function setting 60 is set to "00"

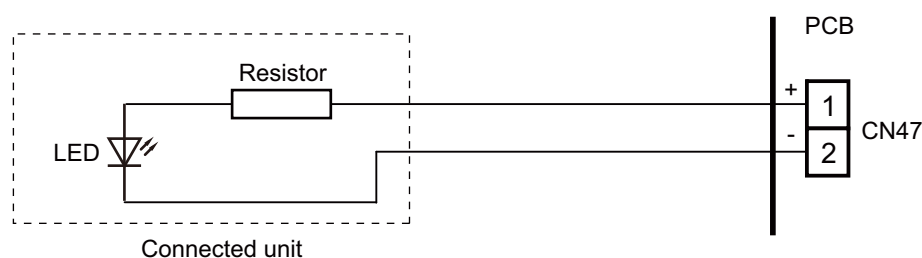

● When connecting with a device equipped with a power supply

Example: Function setting 60 is set to "00"

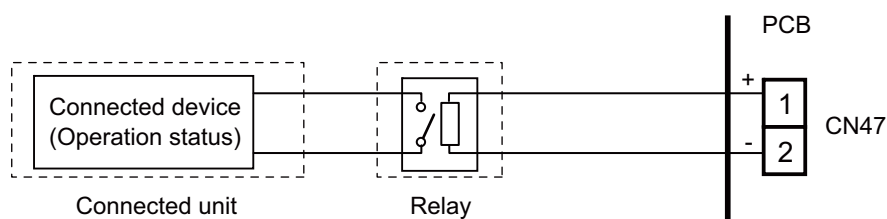

■ External input and output PCB

- A twisted pair cable (22AWG) should be used.
- Permissible voltage and current: DC 5 V to 30 V / 3 A, AC 30 V to 250 V / 3 A
- For details, refer to Chapter 10-3. "Combination of external input and output" on page 57.

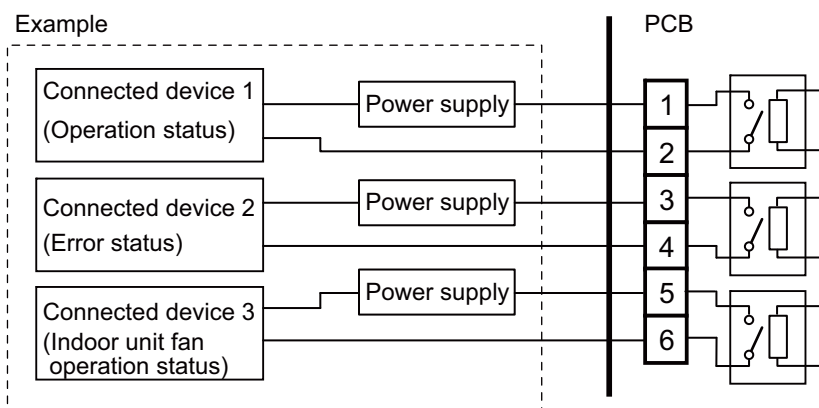

10-3. Combination of external input and output

By combining the function setting of the indoor unit and rotary switch setting of the External input and output PCB, you can select various combinations of functions.

Combination examples of external input and output are as follows:

Mode	Function setting	External input and output PCB (Rotary SW)	External input			
			Indoor unit Input	External input and output PCB		
			Terminal	Input 1	Input 2	Signal type
0-1	60-00	1	Operation/Stop	Operation/Stop	Not available	Edge
				Operation	Stop	Pulse
0-2	60-00	2	Operation/Stop	Forced Thermostat OFF	Not available	Edge
1—8	60-01 to 60-08	3 - 9, A	(Setting prohibited)			
9	60-09	B	Operation/Stop	Forced Thermostat OFF	Not available	Edge
10	60-10	C	Operation/Stop	Forced Thermostat OFF	Not available	Edge
11	60-11	D	Operation/Stop	Forced Thermostat OFF	Not available	Edge

Mode	Function setting	External input and output PCB (Rotary SW)	External output			
			Indoor unit Output	External input and output PCB		
			CN47	Output 1	Output 2	Output 3
0-1	60-00	1	Operation/Stop	Operation/Stop	Error status	Indoor unit fan operation status
0-2	60-00	2	Operation/Stop	Error status	Indoor unit fan operation status	External heater output
1—8	60-01 to 60-08	3 - 9, A	(Setting prohibited)			
9	60-09	B	Error status	Operation/Stop	Indoor unit fan operation status	External heater output
10	60-10	C	Indoor unit fan operation status	Operation/Stop	Error status	External heater output
11	60-11	D	External heater output	Operation/Stop	Indoor unit fan operation status	Error status

NOTE: Input of Operation/Stop depends on the setting of function setting 46.

00: Operation/Stop mode 1 (R.C. enabled)

01: (Setting prohibited)

02: Forced stop

03: Operation/Stop mode 2 (R.C. disabled)

■ Input signal type

- Indoor unit
Input signal type is only "Edge".

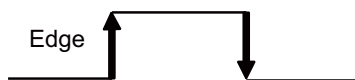

- External input and output PCB
The input signal type can be selected.
Signal type (edge or pulse) can be switched by the DIP switch 2 (SW2) on the External input and output PCB.

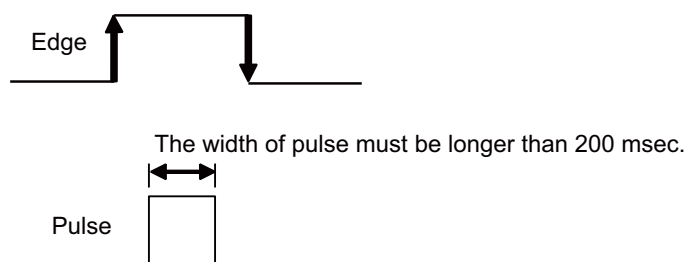

10-4. Details of function

■ Control input function

● When function setting is "Operation/Stop" mode 1

- In the case of "Edge" input

Function setting /	Rotary SW of External input and output PCB	External input		Input signal	Command
		Input of indoor unit	Terminal		
46-00	-	Input of indoor unit	Terminal	Off → On	Operation
				On → Off	Stop
	60-00 / 1	External input and output PCB	Input 1	Off → On	Operation
				On → Off	Stop

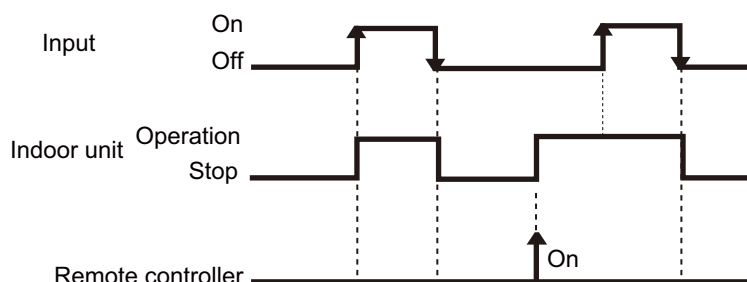

- In the case of "Pulse" input

Function setting /	Rotary SW of External input and output PCB	External input		Input signal	Command
		External input and output PCB	Input 1 / Input 2		
46-00	60-00 / 1	External input and output PCB	Input 1	Pulse	Operation
			Input 2	Pulse	Stop

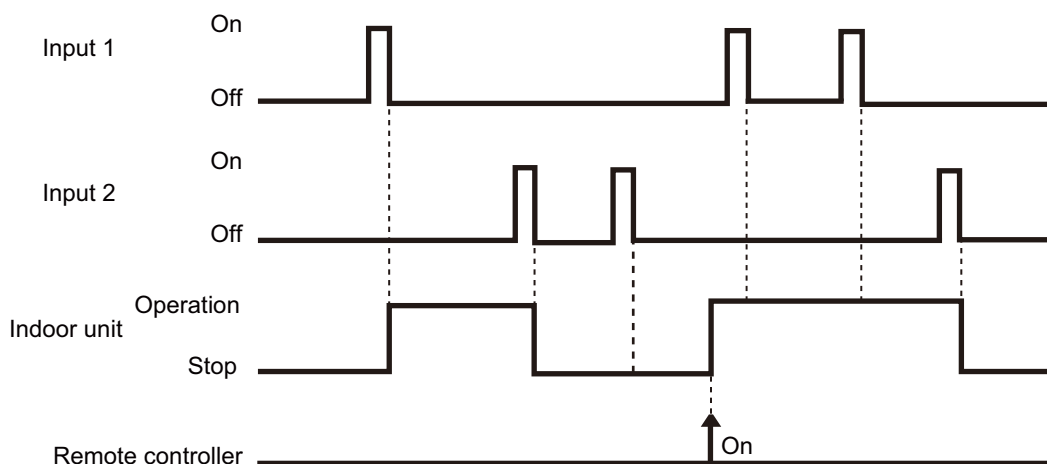

NOTES:

- The last command has priority.
- The indoor units within the same remote controller group operates in the same mode.

● When function setting is "Forced stop" mode

- In the case of "Edge" input

Function setting /	Rotary SW of External input and output PCB	External input		Input signal	Command
46-02	-	Input of indoor unit	Terminal	Off → On	Forced stop
				On → Off	Normal
	60-00 / 1	External input and output PCB	Input 1	Off → On	Forced stop
				On → Off	Normal

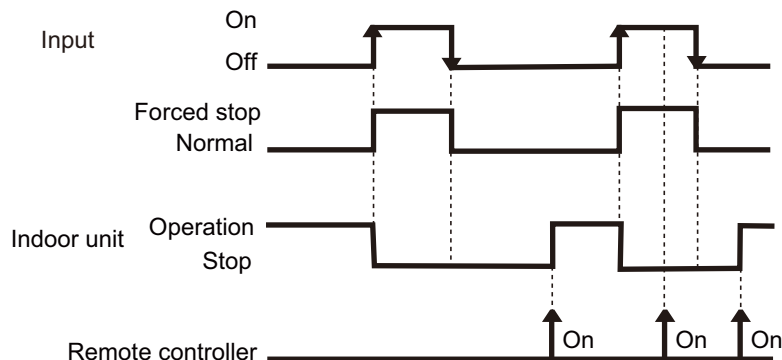

- In the case of "Pulse" input

Function setting /	Rotary SW of External input and output PCB	External input		Input signal	Command
46-02	60-00 / 1	External input and output PCB	Input 1	Pulse	Forced stop
			Input 2	Pulse	Normal

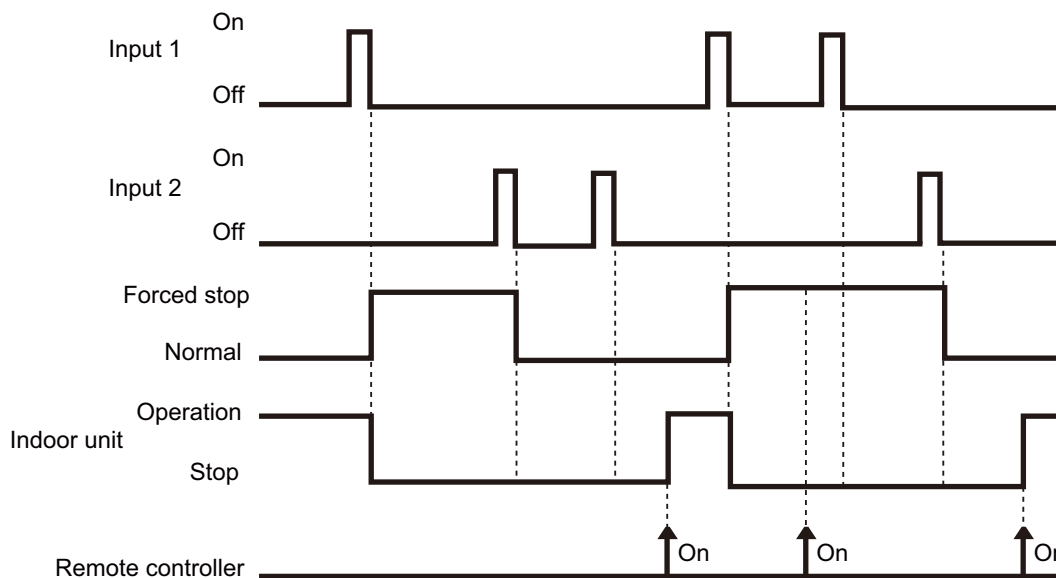

NOTES:

- When the forced stop is triggered, indoor unit stops and Operation/Stop operation by the remote controller is restricted.
- When forced stop function is used with forming a remote controller group, connect the same equipment to each indoor unit within the group.

● When function setting is "Operation/Stop" mode 2

- In the case of "Edge" input

Function setting /	Rotary SW of External input and output PCB	External input		Input signal	Command
46-03	-	Input of indoor unit	Terminal	Off → On	Operation
				On → Off	Stop (R.C. disabled)
	60-00 / 1	External input and output PCB	Input 1	Off → On	Operation
				On → Off	Stop (R.C. disabled)

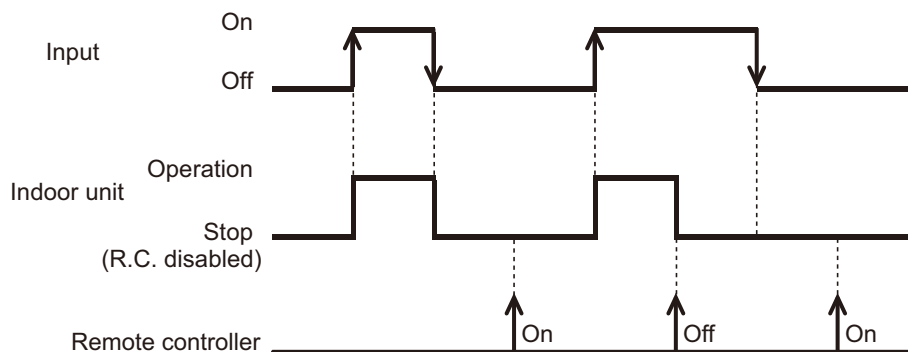

- In the case of "Pulse" input

Function setting /	Rotary SW of External input and output PCB	External input		Input signal	Command
46-03	60-00 / 1	External input and output PCB	Input 1	Pulse	Operation
			Input 2	Pulse	Stop (R.C. disabled)

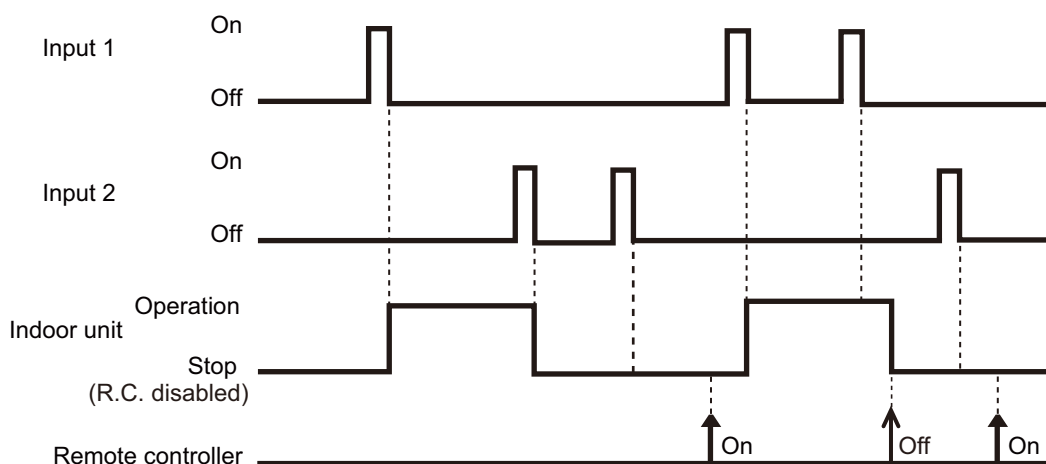

NOTES:

- When "Operation/Stop" mode 2 function is used with forming a remote controller group, connect the same equipment to each indoor unit within the group.

■ Forced thermostat off function

Function setting /	Rotary SW of External input and output PCB	External input		Input signal	Command
60-00 / 2 60-09 / B 60-10 / C 60-11 / D	External input and output PCB	Input 1		Off → On	Thermostat off
				On → Off	Normal operation

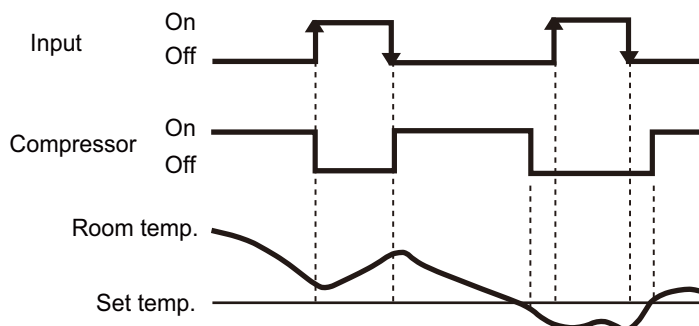

■ Control output function

Function setting /	Rotary SW of External input and output PCB	External output		Output signal	Command
60-00 / 1, 2	Output of indoor unit	CN47		Low → High	Operation
				High → Low	Stop
60-00 / 1 60-09 / B 60-10 / C 60-11 / D	External input and output PCB	Output 1		Off → On	Operation
				On → Off	Stop

The output is low when the unit is stopped.

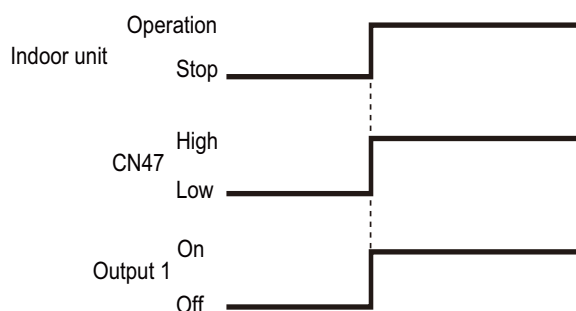

■ Error status

Function setting / Rotary SW of External input and output PCB	External output		Output signal	Command
60-09 / B	Output of indoor unit	CN47	Low → High	Error
			High → Low	Normal
60-00 / 2	External input and output PCB	Output 1	Off → On	Error
			On → Off	Normal
60-00 / 1 60-10 / C		Output 2	Off → On	Error
			On → Off	Normal
60-11 / D		Output 3	Off → On	Error
			On → Off	Normal

The output is ON when an error is generated for the indoor unit.

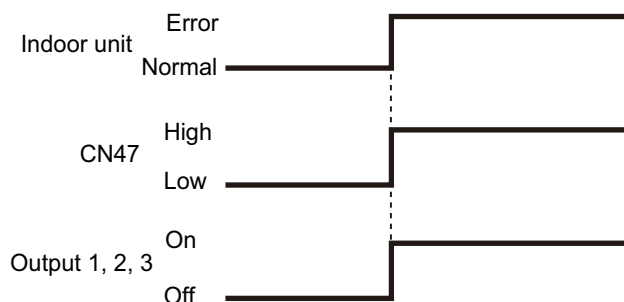

■ Indoor unit fan operation status

Function setting / Rotary SW of External input and output PCB	External output		Output signal	Command
60-10 / C	Output of indoor unit	CN47	Low → High	Fan run
			High → Low	Fan stop
60-00 / 2 60-09 / B 60-11 / D	External input and output PCB	Output 2	Off → On	Fan run
			On → Off	Fan stop
60-00 / 1		Output 3	Off → On	Fan run
			On → Off	Fan stop

Output signal	Condition
On Low → High	The indoor unit fan is operating.
Off High → Low	The fan is stopped or during cold air prevention. During thermostat off when in dry mode operation.

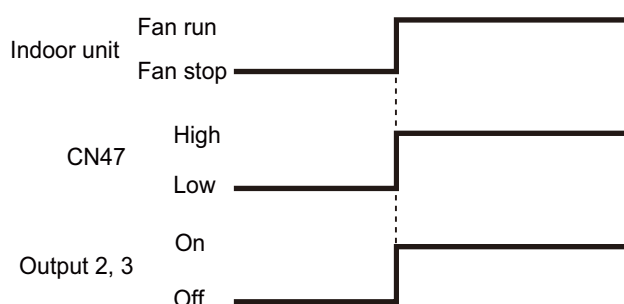

External heater output

Function setting / Rotary SW of External input and output PCB	External output		Output signal	Command
60-11 / D	Output of indoor unit	CN47	Low → High	Heater on
			High → Low	Heater off
60-00 / 2 60-09 / B 60-10 / C	External input and output PCB	Output 3	Off → On	Heater on
			On → Off	Heater off

Output signal	Condition
Low → High Off → On	Heater turns on as shown in diagram of heating temperature
High → Low On → Off	Heater turns off as shown in diagram of heating temperature <ul style="list-style-type: none"> • Other than Heating mode • Error occurred • Forced thermo off • Fan stop protection

Specifications of the signal output performance are as shown as follows:

Example: When set temperature (T_s) is set at 22 °C;

- And room temperature (T_r) increase above 12 °C, signal output is on.
- And T_r increase above 21 °C, signal output is off.
- And T_r decrease below 19 °C, signal output is on.
- And T_r decrease below 10 °C, signal output is off.

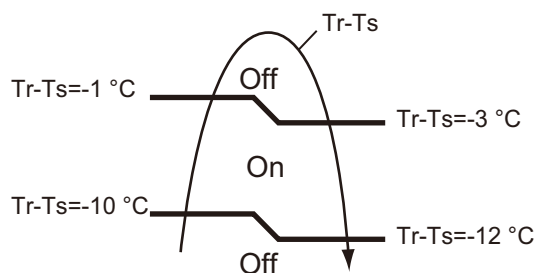

The output also turns off in defrost operation.

11. Function settings

To adjust the functions of this product according to the installation environment, various types of function settings are available.

NOTE: Incorrect settings can cause a product malfunction.

11-1. Function settings on indoor unit

By using some components on the PCB, you can change the function settings.

■ Component location

Components on the indoor unit main PCB used for the function settings are located as shown in the following figure.

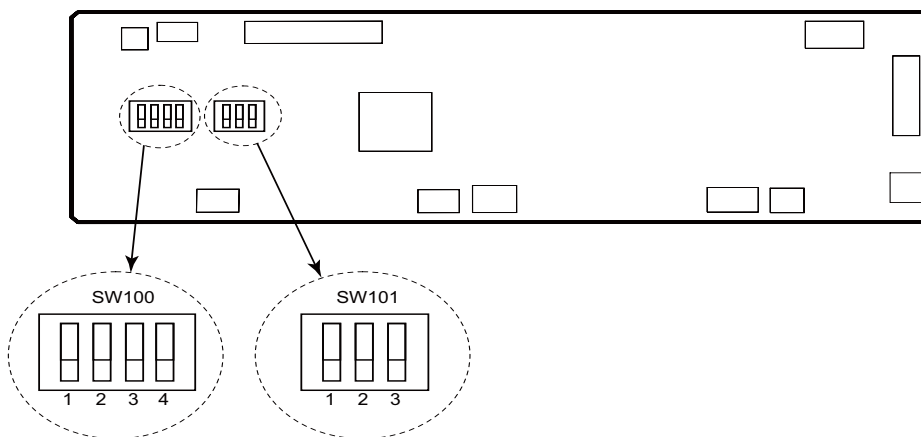

■ DIP switch setting

- Remote controller address setting (SW100)

NOTE: Because this setting is normally done automatically when 2-core wired remote controller is installed, setting is unnecessary.

Multiple indoor units can be operated by using one wired remote controller.

Set the unit number of each indoor unit.

Remote controller address	DIP switch number				Factory setting
	1	2	3	4	
00	OFF	OFF	OFF	OFF	◆
01	ON	OFF	OFF	OFF	
02	OFF	ON	OFF	OFF	
03	ON	ON	OFF	OFF	
04	OFF	OFF	ON	OFF	
05	ON	OFF	ON	OFF	
06	OFF	ON	ON	OFF	
07	ON	ON	ON	OFF	
08	OFF	OFF	OFF	ON	
09	ON	OFF	OFF	ON	
10	OFF	ON	OFF	ON	
11	ON	ON	OFF	ON	
12	OFF	OFF	ON	ON	
13	ON	OFF	ON	ON	
14	OFF	ON	ON	ON	
15	ON	ON	ON	ON	

NOTES:

- When connecting Polar 3-core wired remote controller, set the remote controller address in the order of 0, 1, 2,, and 15.
- When different type of indoor units (such as wall-mounted type and cassette type, cassette type and duct type, or other combinations) are connected using group control system, some functions may no longer be available.

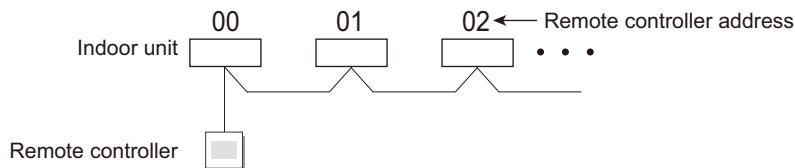

- **SW101: Setting change prohibited**

11-2. Function settings by using remote controller

Some function settings can be changed on the remote controller. After confirming the setting procedure and the content of each function setting, select appropriate functions for your installation environment.

■ Setting procedure by using wired remote controller

The function number and the associated setting value are displayed on the LCD of the remote controller. Follow the instructions written in the local setup procedure supplied with the remote controller, and select appropriate setting according to the installation environment.

Before connecting the power supply of the indoor unit, reconfirm following items:

- Piping air tight test and vacuuming have been performed firmly.
 - There is no wiring mistake.
1. Connect the power supply.
 2. Touch the “Function Setting” on the “Maintenance” screen. The “Function Setting” screen is displayed. Then touch the “Address” on the “Function Setting” screen.

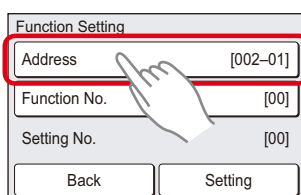

3. “Address” screen is displayed. Select the address of the indoor unit whose function number is to be set by touching ▲ or ▼. When setting at all the indoor units, touch “All”.

NOTE: Perform this step only when the remote controller address setting is required. Otherwise, skip this step.

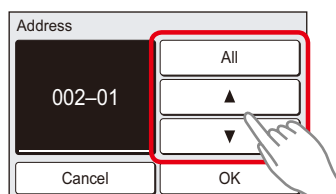

4. Touch the “Function No.” on the “Function Setting” screen.

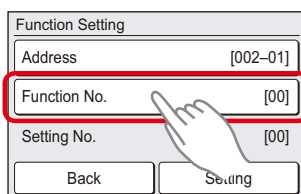

5. “Function No.” screen is displayed. Set the function number “11” by touching ▲ or ▼. When the “OK” is touched, the display returns to the “Function Setting” screen.

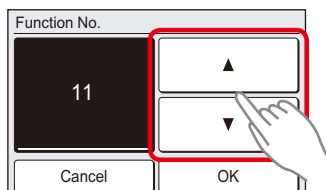

6. Touch the "Setting" on the "Function Setting" screen.

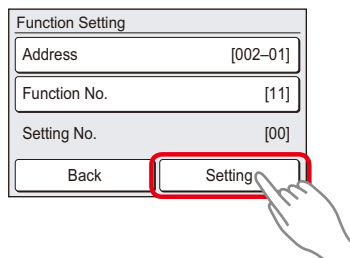

7. Setting screen of "Setting No." is displayed. Set the setting number by touching ▲ or ▼. (The setting range is from 00 to 99.) When the "OK" is touched, the "Function Setting" verification screen is displayed.

Example: When configuring the setting number of filter sign.

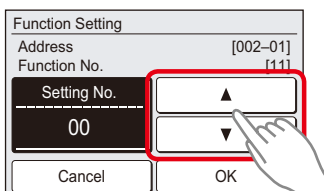

8. When the "Back" on the "Function Setting" screen is touched, the display returns to the "Maintenance" screen.

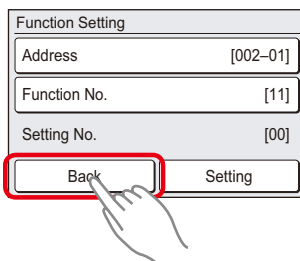

9. After completing the function setting, be sure to turn off the power and turn it on again.

⚠ CAUTION

After turning off the power, wait 30 seconds or more before turning on the power again. The function setting will not become active unless the power is turned off then on again.

■ Contents of function setting

Each function setting listed in this section is adjustable in accordance with the installation environment.

NOTE: Setting will not be changed if invalid numbers or setting values are selected.

● Function setting list

	Function no.	Functions
1)	11	Filter sign
2)	20	Ceiling height
3)	22	Outlet directions
4)	23	Vertical airflow direction range control
5)	30/31	Room temperature control for indoor unit sensor
6)	35/36	Room temperature control for wired remote controller sensor
7)	40	Auto restart
8)	42	Room temperature sensor switching
9)	44	Remote controller custom code
10)	46	External input control
11)	48	Room temperature sensor switching (Aux.)
12)	49	Indoor unit fan control for energy saving for cooling
13)	60	Switching functions for external output terminal

1) Filter sign

Select appropriate intervals for displaying the filter sign on the indoor unit according to the estimated amount of dust in the air of the room.

If the indication is not required, select "No indication" (03).

Function number	Setting value	Setting description	Factory setting
11	00	Standard (2,500 hours)	
	01	Long interval (4,400 hours)	
	02	Short interval (1,250 hours)	
	03	No indication	◆

2) Ceiling height

Select the appropriate ceiling height according to the place of installation.

Function number	Setting value	Setting description	Factory setting
20	00	Standard	◆
	01	High ceiling	
	02	Low ceiling	

For the specific height for each setting value, refer to "Installation space" in Chapter 4. "[Dimensions](#)" on page 15.

In case of cassette type models:

The ceiling height values are for the 4-way outlet. Do not change this setting in the 3-way outlet mode.

3) Outlet directions

Select the appropriate number of outlet directions according to the installation conditions.

Function number	Setting value	Setting description	Factory setting
22	00	4-way	◆
	01	3-way	

4) Vertical airflow direction range control

To prevent draft, change the setting to "Upward" (01).

Note that the airflow in certain usage conditions may leave the ceiling dirty. In such cases, the use of the optional Panel spacer is recommended.

Function number	Setting value	Setting description	Factory setting
23	00	Standard	◆
	01	Upward	

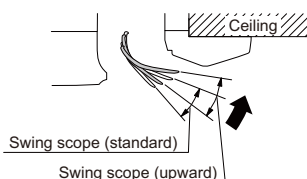

5) Room temperature control for indoor unit sensor

Depending on the installed environment, correction of the room temperature sensor may be required. Select the appropriate control setting according to the installed environment.

The temperature correction values show the difference from the Standard setting "00" (manufacturer's recommended value).

Function number	Setting value	Setting description	Factory setting		
30 (For cooling)	31 (For heating)	00	Standard setting	◆	
		01	No correction 0.0 °C		
		02	-0.5 °C	More cooling Less heating	
		03	-1.0 °C		
		04	-1.5 °C		
		05	-2.0 °C		
		06	-2.5 °C		
		07	-3.0 °C		
		08	-3.5 °C		
		09	-4.0 °C		
		10	+0.5 °C	Less cooling More heating	
		11	+1.0 °C		
		12	+1.5 °C		
		13	+2.0 °C		
		14	+2.5 °C		
		15	+3.0 °C		
		16	+3.5 °C		
17	+4.0 °C				

6) Room temperature control for wired remote controller sensor

Depending on the installed environment, correction of the wire remote temperature sensor may be required. Select the appropriate control setting according to the installed environment.

To change this setting, set Function 42 to Both "01".

Ensure that the Thermo Sensor icon is displayed on the remote controller screen.

Function number		Setting value	Setting description	Factory setting	
35 (For cooling)	36 (For heating)	00	No correction	◆	
		01	No correction 0.0°C		
		02	-0.5 °C	More cooling Less heating	
		03	-1.0 °C		
		04	-1.5 °C		
		05	-2.0 °C		
		06	-2.5 °C		
		07	-3.0 °C		
		08	-3.5 °C		
		09	-4.0 °C		
		10	+0.5 °C	Less cooling More heating	
		11	+1.0 °C		
		12	+1.5 °C		
		13	+2.0 °C		
		14	+2.5 °C		
		15	+3.0 °C		
		16	+3.5 °C		
17	+4.0 °C				

7) Auto restart

Enables or disables automatic restart after a power interruption.

Function number	Setting value	Setting description	Factory setting
40	00	Enable	◆
	01	Disable	

NOTE: Auto restart is an emergency function such as for power outage etc. Do not attempt to use this function in normal operation. Be sure to operate the unit by remote controller or external device.

8) Room temperature sensor switching

(Only for wired remote controller)

When using the wired remote controller temperature sensor, change the setting to "Both" (01).

Function number	Setting value	Setting description	Factory setting
42	00	Indoor unit	◆
	01	Both	

00: Sensor on the indoor unit is active.

01: Sensors on both indoor unit and wired remote controller are active.

NOTE: Remote controller sensor must be turned on by using the remote controller.

9) Remote controller custom code

(Only for wireless remote controller)

The indoor unit custom code can be changed. Select the appropriate custom code.

Function number	Setting value	Setting description	Factory setting
44	00	A	◆
	01	B	
	02	C	
	03	D	

10) External input control

"Operation/Stop" mode or "Forced stop" mode can be selected.

Function number	Setting value	Setting description	Factory setting
46	00	Operation/Stop mode 1	◆
	01	(Setting prohibited)	
	02	Forced stop mode	
	03	Operation/Stop mode 2	

11) Room temperature sensor switching (Aux.)

To use the temperature sensor on the wired remote controller only, change the setting to "Wired remote controller" (01).

This function will only work if the function setting 42 is set at "Both" (01).

When the setting value is set to "Both" (00), more suitable control of the room temperature is possible by setting function setting 30 and 31 too.

Function number	Setting value	Setting description	Factory setting
48	00	Both	◆
	01	Wired remote controller	

12) Indoor unit fan control for energy saving for cooling

Enables or disables the power-saving function by controlling the indoor unit fan rotation when the outdoor unit is stopped during cooling operation.

Function number	Setting value	Setting description	Factory setting
49	00	Disable	
	01	Enable	
	02	Remote controller	◆

00: When the outdoor unit is stopped, the indoor unit fan operates continuously following the setting on the remote controller.

01: When the outdoor unit is stopped, the indoor unit fan operates intermittently at a very low speed.

02: Enable or disable this function by remote controller setting.

NOTES:

- As the factory setting, this setting is initially activated.
- Set to "00" or "01" when connecting a remote controller that cannot set the Fan control for energy saving function or connecting a network converter.
To confirm if the remote controller has this setting, refer to the operating manual of each remote controller.

13) Switching functions for external output terminal

Functions of the external output terminal can be switched. For details, refer to “External input and output”.

Function number	Setting value	Setting description	Factory setting
60	00	Operation status	◆
	01 - 08	(Setting prohibited)	
	09	Error status	
	10	Indoor unit fan operation status	
	11	External heater	

12. Wired remote controller (Touch panel)

12-1. Remote controller address setting

■ How to confirm the remote controller address

NOTE: The address of this remote controller is set automatically. Do not change the indoor unit remote controller address from the factory setting "0". (Verify that the address is "0".)

1. When the [RC Address Setting] on the "Maintenance" screen is touched, the "Installer Password Verification" screen is displayed.

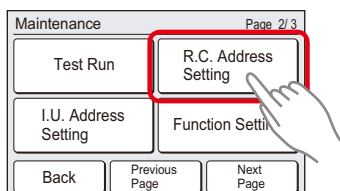

2. Enter the installer password, and touch the [OK]. "R.C. Address Setting" screen is displayed. The address of this unit is displayed on the "R.C. Address Setting" screen.

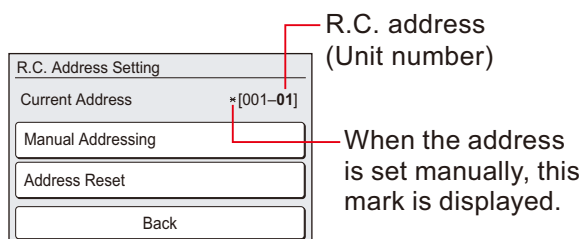

3. When the [Back] is touched, the display returns to the "Maintenance" screen.

■ How to set the remote controller address manually

NOTE: Perform manual address setting only when setting the address with an arbitrary number. Indoor unit remote controller address setting is necessary.

1. Touch the [Manual Addressing] on the "R.C. Address Setting" screen.

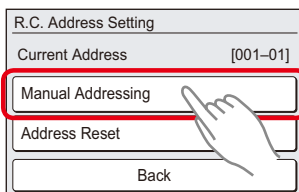

2. "Manual Addressing" screen is displayed. Set the address with [▲] or [▼]. When the [OK] is touched, a verification screen is displayed.

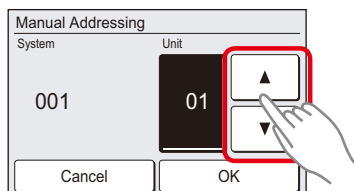

- When the [Yes] on the verification screen is touched, a message screen is displayed.

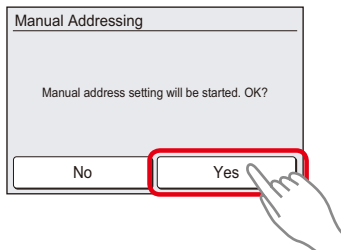

- When the [Close] on the message screen is touched, the display returns to the “R.C. Address Setting” screen. Turn on the power again.

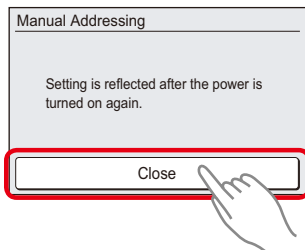

NOTES:

- Indoor unit remote controller address setting is necessary.
- Set the remote controller address of indoor units connected by the same remote controller cable within a range of 1 to 9 and A (10) to F(15) so that there is no duplication. (Do not set to "0".)
- The address of remote controller is set within a range of 1 to 32, but set it so that it does not duplicate the remote controller address of an indoor unit connected by the same remote controller cable.

How to reset the manual address setting number

- Touch the [Address Reset] on the “R.C. Address Setting” screen.

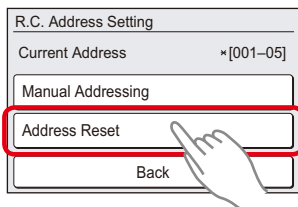

- A verification screen is displayed. When the [Yes] is touched, a verification screen is displayed.

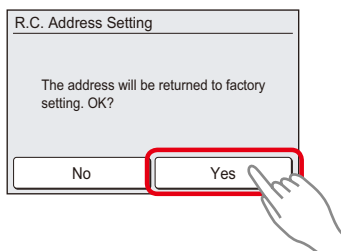

- When the [Close] on the message screen is touched, the display returns to the “R.C. Address Setting” screen. Turn on the power again.

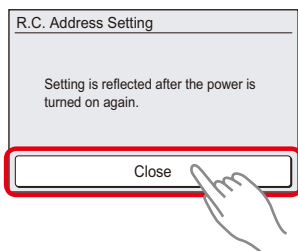

12-2. Remote controller master/slave setting

1. Touch the [RC Master/Slave Setting] on the “Initial Setting” screen.

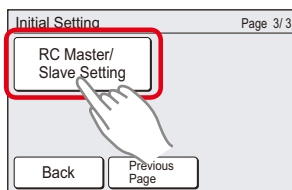

2. “RC Master/Slave Setting” screen is displayed. Select the [Master] or [Slave].

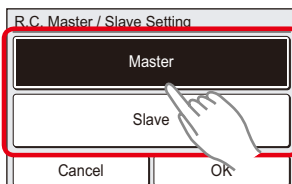

NOTES:

- Set only one Master remote controller. Units specified other than [Master] are set to [Slave] automatically.
- Do not perform “RC Mater/Slave Setting” during setting or operating from the Master remote controller.

12-3. Memory backup setting

Before using this product, always set DIP switch to “ON”. If not set, when the main power supply is reconnected, the set data by menu operation will be erased and cause erroneous operation.

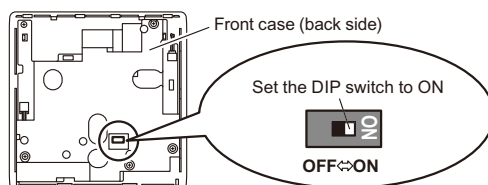

DIP Switch



- Performs the enabling/disabling of the backup function by the internal battery.
- It is disabled when shipped from the factory to prevent consumption of the charge.

⚠ CAUTION

Do not touch the DIP switch with your hands. Use an insulated screwdriver to set the DIP switches. Do not touch the DIP switch with your hands.

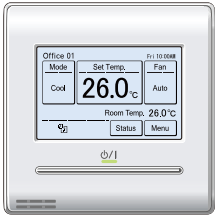
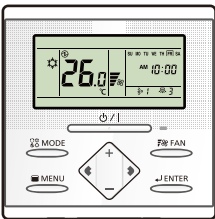
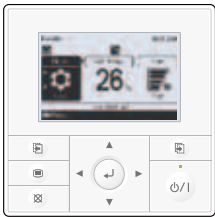
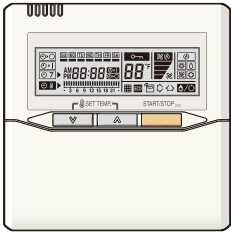

13. Optional parts

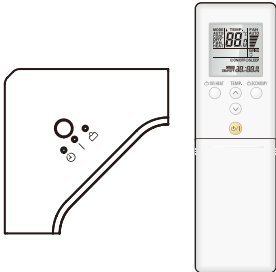
13-1. Controllers



Exterior	Part name	Model name	Summary
	Wired remote controller	UTY-RNRYZ1	Easy finger touch operation with LCD panel. Backlit LCD enables easy operation in a dark room. Wire type: Non-polar 2-wire
	Wired remote controller	UTY-RLRY	High visibility and easy operation. Room temperature can be accurately controlled using the built-in thermo sensor. Wire type: Non-polar 2-wire
	Wired remote controller	UTY-RVNYM	Large and full-dot liquid crystal screen, wide and large keys easy to press, user-intuitive arrow key. Wire type: Polar 3-wire
	Wired remote controller	UTY-RNNYM	Room temperature can be controlled by detecting the temperature accurately with built-in thermo sensor. Wire type: Polar 3-wire
	Simple remote controller	UTY-RSNYM	Compact remote controller concentrates on the basic functions such as Start/Stop, fan control, temperature setting, and operation mode. Wire type: Polar 3-wire
	IR receiver unit	UTY-LBTYC	Unit control is performed by wireless remote controller.

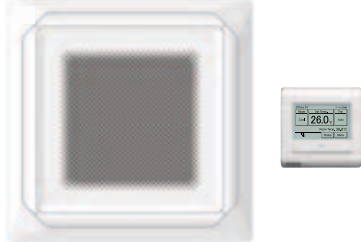

NOTE: Available functions may differ by the remote controller. For details, refer to the operation manual.

13-2. Cassette grille

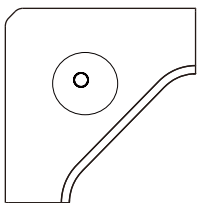
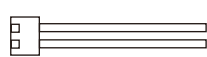
Exterior	Part name	Model name	Summary
	Cassette grille	UTG-UKYA-W	The form of grille discharges wind away from the ceiling making it difficult to leave dirt marks. Wired remote controller (UTY-RNRYZ1) is included.
	Cassette grille	UTG-UKYA-B	The form of grille discharges wind away from the ceiling making it difficult to leave dirt marks.

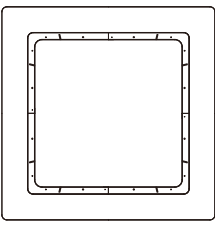
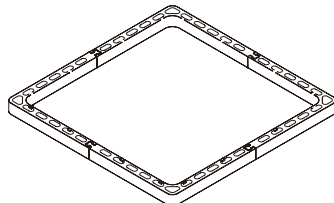
13-3. Others

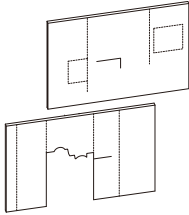
Exterior	Part name	Model name	Summary
	Human sensor kit	UTY-SHZXC	Human sensor for cassette. UTY-RNRYZ1 is necessary for function setting.
	External connect kit	UTY-XWZXZG	Use to connect with various peripheral devices and air conditioner PCB. For control output port.
	Air outlet shutter plate	UTR-YDZK	Installed at the air outlet when 3-directions mode is performed.
	Wide panel	UTG-AKXA-W	Hides the gap between the ceiling hole and the cassette grille.
	Panel spacer	UTG-BKXA-W	If there is not enough height in the ceiling space, by inserting this spacer between the cassette grille and the ceiling surface, the height of the unit body goes into the ceiling space become 50-mm lower.

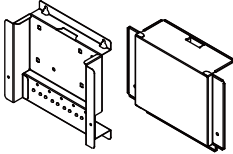
Exterior	Part name	Model name	Summary
	Fresh-air intake kit	UTZ-VXRA	By attaching Fresh-air intake kit to the indoor unit, it can be taken in fresh air of up to 10% of "high" air volume of the indoor unit.
	Insulation for high humidity	UTZ-KXRA	Install when the under-roof condition is expected to be the humidity of over 80% and the temperature of over 30 °C.
	External input and output PCB	UTY-XCSX	Use to connect with external devices and air conditioner PCB.
	External input and output PCB box	UTZ-GXRA	For installing the External input and output PCB.

Part 2. OUTDOOR UNIT

SINGLE TYPE:

AOYG18LBCA

AOYG24LBCA

AOYG30LBTA

AOYG36LBTA

AOYG45LBTA

AOYG54LBTA

1. Specifications

1-1. Models: AOYG18LBCA and AOYG24LBCA

Type			Inverter heat pump		
Model name			AOYG18LBCA	AOYG24LBCA	
Power supply			230 V ~ 50 Hz		
Available voltage range			198—264 V		
Starting current			A		
Fan	Airflow rate	Cooling	6.6	9.6	
		Heating	1,900	2,460	
	Type × Q'ty		1,700	2,340	
	Motor output		Propeller × 1		
Sound pressure level *1	Cooling		49		
	Heating		51	55	
Sound power level	Cooling		50	56	
	Heating		64	68	
Heat exchanger type	Dimensions (H × W × D)		Main: 588 × 881 × 18.2 Sub: 525 × 580 × 18.2		
	Fin pitch		1.45		
	Rows × Stages		Main: 2 × 28 Sub: 1 × 26		
	Pipe type		Copper		
	Fin type		Type (Material)	Corrugate (Aluminum)	
			Surface treatment	Corrosion resistance	
Compressor	Type × Q'ty		Twin rotary × 1		
	Motor output		W	1,100	
Refrigerant	Type (Global Warming Potential)		R410A (1975)		
	Charge		g	1,800	
Refrigerant oil	Type		RB68		
	Amount		cm ³	600	
Enclosure	Material		Steel sheet		
	Color		Beige Approximate color of MUNSSELL 10YR7.5/1.0		
Dimensions (H × W × D)	Net		620 × 790 × 290		
	Gross		713 × 945 × 395		
Weight	Net		41		
	Gross		45		
Connection pipe	Size	Liquid	Ø 6.35 (Ø 1/4)		
		Gas	Ø 12.70(Ø 1/2)	Ø 15.88 (Ø 5/8)	
	Method		Flare		
	Pre-charge length		15		
	Max. length		30		
	Max. height difference		20		
Operation range	Cooling		-15 to 46		
	Heating		-15 to 24		
Drain hose	Material		LDPE		
	Size		Ø 13.0 (I.D.), Ø 16.0 to Ø 16.7 (O.D.)		

NOTES:

- Specifications are based on the following conditions:
 - Cooling: Indoor temperature of 27 °CDB/19 °CWB, and outdoor temperature of 35 °CDB/24 °CWB.
 - Heating: Indoor temperature of 20 °CDB/15 °CWB, and outdoor temperature of 7 °CDB/6 °CWB.
 - Pipe length: 5 m, Height difference: 0 m.
- Protective function might work when using it outside the operation range.
- *1: Sound pressure level
 - Measured values in manufacturer's anechoic chamber.
 - Because of the surrounding sound environment, the sound levels measured in actual installation conditions might be higher than the specified values here.

1-2. Models: AOYG30LBTA and AOYG36LBTA

Type			Inverter heat pump		
Model name			AOYG30LBTA	AOYG36LBTA	
Power supply			230 V ~ 50 Hz		
Available voltage range			198—264 V		
Starting current			A		
			12.2	13.0	
Fan	Airflow rate	Cooling	m ³ /h	3,600	3,800
		Heating		3,600	3,800
	Type × Q'ty	Propeller × 1			
Motor output			W	100	
Sound pressure level *1	Cooling		dB (A)	53	54
	Heating			55	55
Sound power level	Cooling		dB (A)	67	68
	Heating			69	70
Heat exchanger type	Dimensions (H × W × D)		mm	798 × 900 × 36.4	
	Fin pitch			1.30	
	Rows × Stages			2 × 38	
	Pipe type			Copper	
	Fin type	Type (Material)		Corrugate (Aluminum)	
		Surface treatment	Corrosion resistance (Blue fin)		
Compressor	Type × Q'ty		Twin rotary × 1		
	Motor output		W	2,100	
Refrigerant	Type (Global Warming Potential)		R410A (1975)		
	Charge		g	2,100	
Refrigerant oil	Type		RmM68AF		
	Amount		cm ³	800	
Enclosure	Material		Steel sheet		
	Color		Beige Approximate color of MUNSELL 10YR7.5/1.0		
Dimensions (H × W × D)	Net		mm	830 × 900 × 330	
	Gross			1,000 × 1,050 × 445	
Weight	Net		kg	61	
	Gross			69	
Connection pipe	Size	Liquid	mm(in)	Ø 9.52 (Ø 3/8)	
		Gas		Ø 15.88 (Ø 5/8)	
	Method		Flare		
	Pre-charge length		m	20	
	Max. length			50	
Max. height difference		30			
Operation range	Cooling		°C	-15 to 46	
	Heating			-15 to 24	
Drain hose	Material		LDPE		
	Size		mm	Ø 13.0 (I.D.), Ø 16.0 to Ø 16.7 (O.D.)	
NOTES: <ul style="list-style-type: none"> Specifications are based on the following conditions: <ul style="list-style-type: none"> – Cooling: Indoor temperature of 27 °CDB/19 °CWB, and outdoor temperature of 35 °CDB/24 °CWB. – Heating: Indoor temperature of 20 °CDB/15 °CWB, and outdoor temperature of 7 °CDB/6 °CWB. – Pipe length: 5 m, Height difference: 0 m. Protective function might work when using it outside the operation range. *1: Sound pressure level <ul style="list-style-type: none"> – Measured values in manufacturer's anechoic chamber. – Because of the surrounding sound environment, the sound levels measured in actual installation conditions might be higher than the specified values here. 					

1-3. Models: AOYG45LBTA and AOYG54LBTA

OUTDOOR UNIT
AOYG18-54LB

Type			Inverter heat pump		
Model name			AOYG45LBTA	AOYG54LBTA	
Power supply			230 V ~ 50 Hz		
Available voltage range			198—264 V		
Starting current			A		
			16.8	20.0	
Fan	Airflow rate	Cooling	m ³ /h	6,750	6,750
		Heating		6,200	6,850
	Type × Q'ty	Propeller × 2			
Motor output			W	100	
Sound pressure level *1		Cooling	dB (A)	55	55
		Heating		55	57
Sound power level		Cooling	dB (A)	68	69
		Heating		68	71
Heat exchanger type	Dimensions (H × W × D)		mm	1,260 × 900 × 36.4	
	Fin pitch			1.30	
	Rows × Stages			2 × 60	
	Pipe type			Copper	
	Fin type		Type (Material)	Corrugate (Aluminum)	
		Surface treatment	Corrosion resistance (Blue fin)		
Compressor	Type × Q'ty		Twin rotary × 1		
	Motor output		W	2,100	
Refrigerant	Type (Global Warming Potential)		R410A (1975)		
	Charge		g	3,350	
Refrigerant oil	Type		RmM68AF		
	Amount		cm ³	800	
Enclosure	Material		Steel sheet		
	Color		Beige Approximate color of MUNSELL 10YR7.5/1.0		
Dimensions (H × W × D)	Net		mm	1,290 × 900 × 330	
	Gross			1,460 × 1,050 × 445	
Weight	Net		kg	86	
	Gross			95	
Connection pipe	Size	Liquid	mm(in)	Ø 9.52 (Ø 3/8)	
		Gas		Ø 15.88 (Ø 5/8)	
	Method		Flare		
	Pre-charge length		m	20	
	Max. length			50	
Max. height difference		30			
Operation range		Cooling	°C	-15 to 46	
		Heating		-15 to 24	
Drain hose	Material		LDPE		
	Size		mm	Ø 13.0 (I.D.), Ø 16.0 to Ø 16.7 (O.D.)	

NOTES:

- Specifications are based on the following conditions:
 - Cooling: Indoor temperature of 27 °CDB/19 °CWB, and outdoor temperature of 35 °CDB/24 °CWB.
 - Heating: Indoor temperature of 20 °CDB/15 °CWB, and outdoor temperature of 7 °CDB/6 °CWB.
 - Pipe length: 5 m, Height difference: 0 m.
- Protective function might work when using it outside the operation range.
- *1: Sound pressure level
 - Measured values in manufacturer's anechoic chamber.
 - Because of the surrounding sound environment, the sound levels measured in actual installation conditions might be higher than the specified values here.

2. Dimensions

2-1. Models: AOYG18LBCA and AOYG24LBCA

Unit: mm

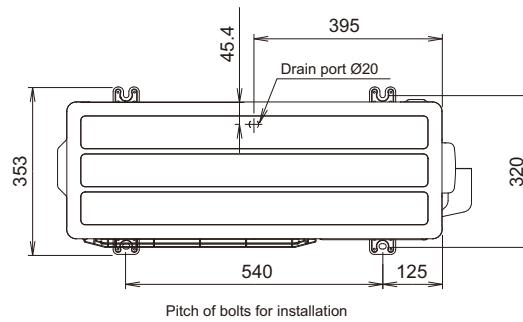

Top view

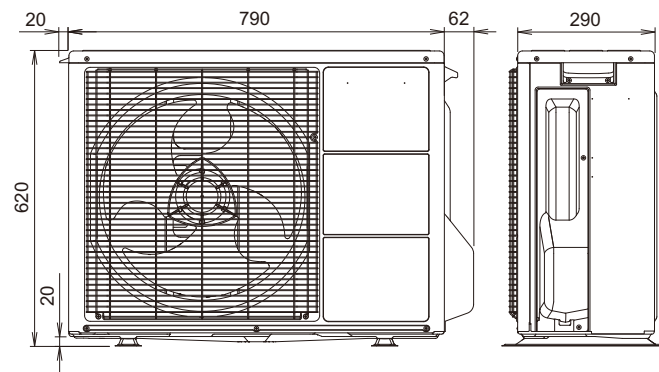

Front view

Side view

2-2. Models: AOYG30LBTA and AOYG36LBTA

Unit: mm

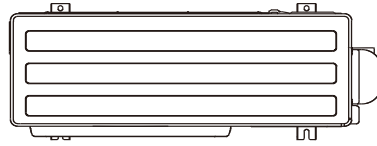

Top view

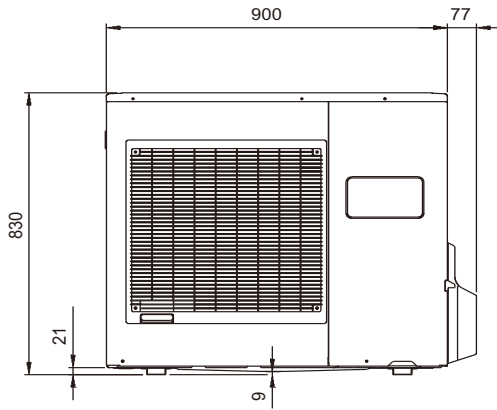

Front view

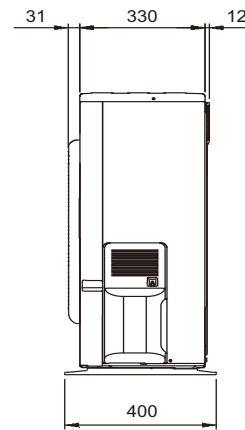

Side view

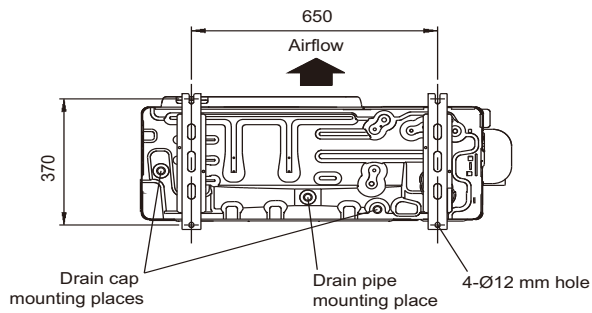

Bottom view

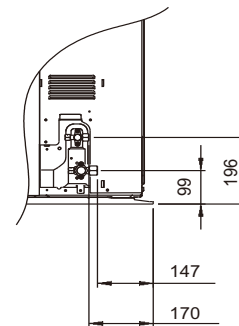

OUTDOOR UNIT
AOYG18-54LB

2-3. Models: AOYG45LBTA and AOYG54LBTA

Unit: mm

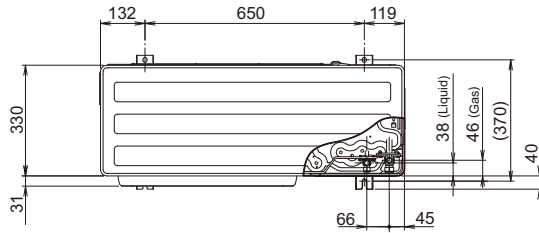

Top view

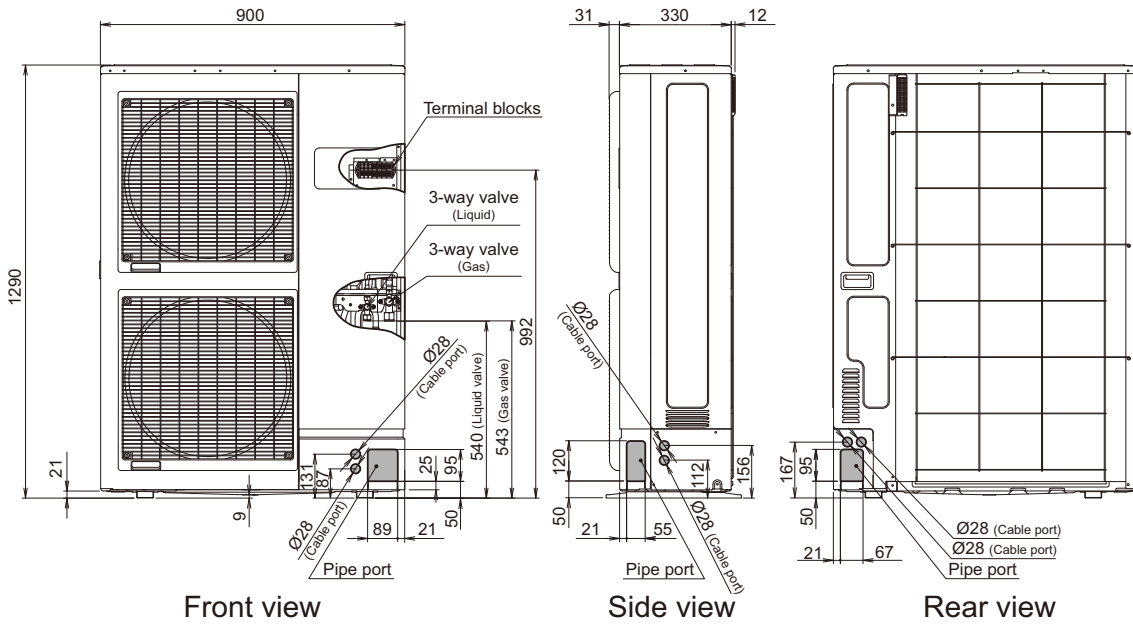

Front view

Side view

Rear view

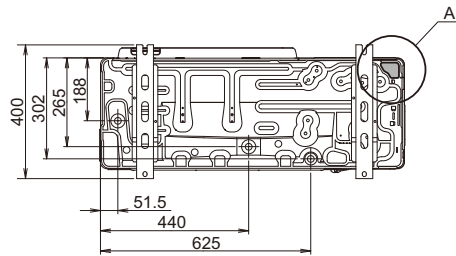

Bottom view

Detail A

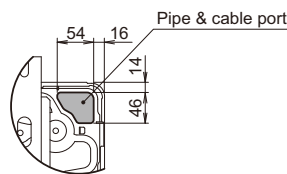

3. Installation space

3-1. Models: AOYG18LBCA and AOYG24LBCA

■ Space requirement

Provide sufficient installation space for product safety.

● Single outdoor unit installation

- When the upper space is open:

Unit: mm

When there are obstacles at the rear only.

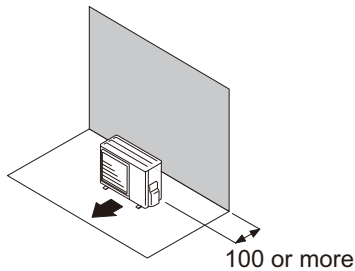

When there are obstacles at the rear and sides.

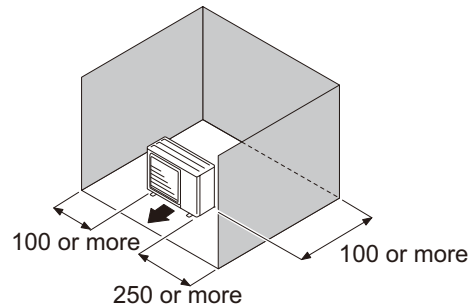

When there are obstacles at the front only.

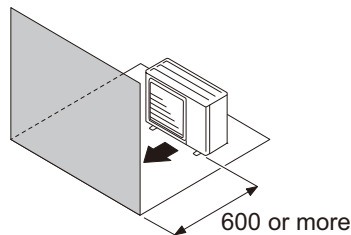

When there are obstacles at the front and rear.

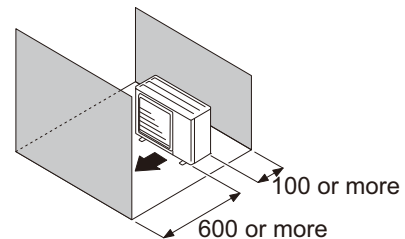

- When there is an obstruction in the upper space:

Unit: mm

When there are obstacles at the rear and above.

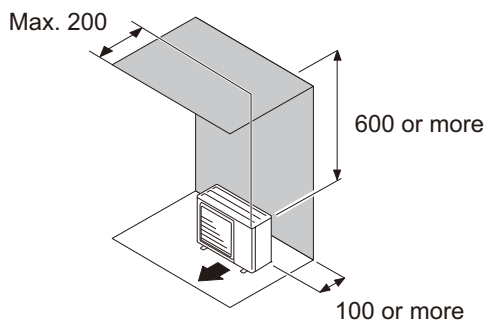

When there are obstacles at the rear, sides, and above.

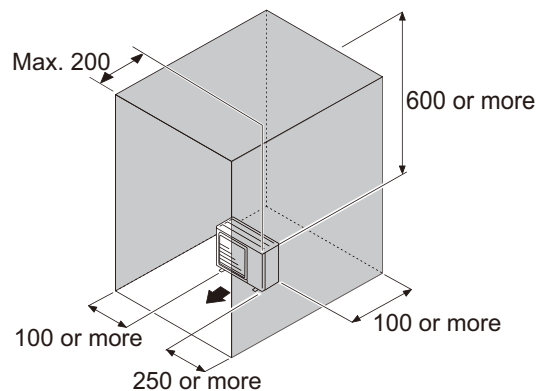

● Multiple outdoor unit installation

- When the upper space is open:

Unit: mm

When there are obstacles at the rear only.

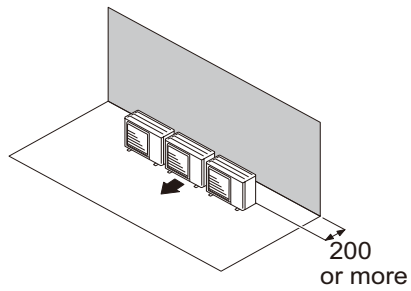

When there are obstacles at the front only.

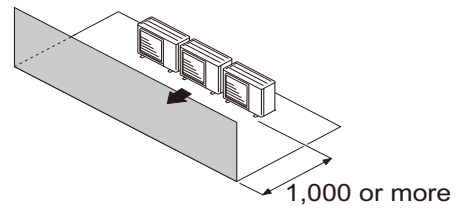

When there are obstacles at the front and rear.

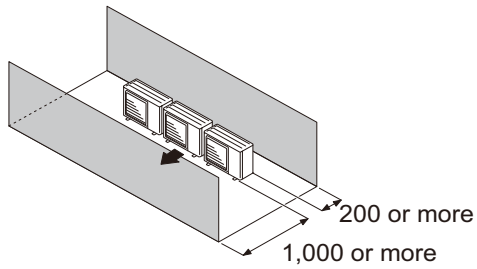

- When there is an obstruction in the upper space:

Unit: mm

When there are obstacles at the rear and above.

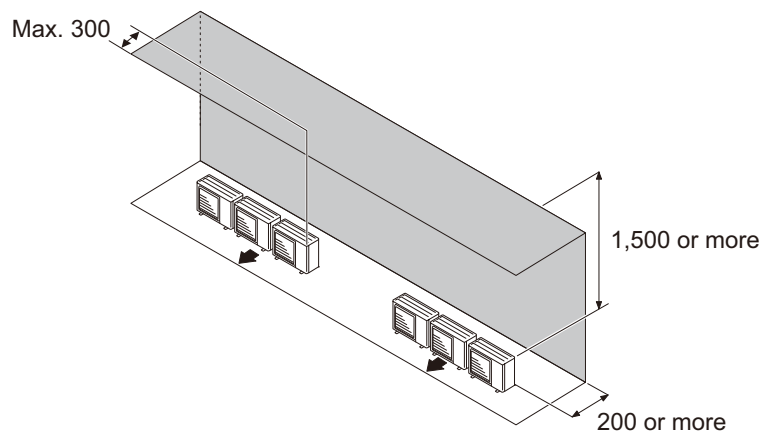

● Outdoor unit installation in multi-row

Unit: mm

Single parallel unit arrangement

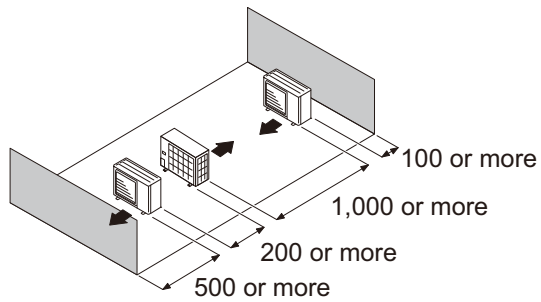

Multiple parallel unit arrangement

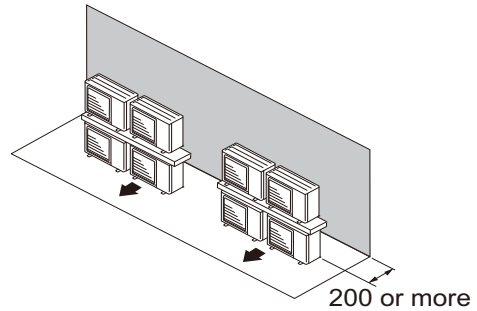
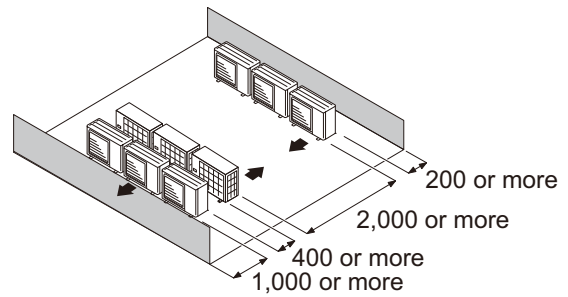

NOTES:

- If the space is larger than stated above, the condition will be the same as when there is no obstacle.
- Height above the floor level should be 50 mm or more.
- When installing the outdoor unit, be sure to open the front and left side to obtain better operation efficiency.

⚠ CAUTION

- Do not install the outdoor unit in two-stage where the drain water could freeze. Otherwise the drainage from the upper unit may form ice and cause a malfunction of the lower unit.
- When the outdoor temperature is 0 °C or less, do not use the accessory drain pipe and drain cap. If the drain pipe and drain cap are used, the drain water in the pipe may freeze in extremely cold climate. (For reverse cycle model only.)
- In area with heavy snowfall, if the inlet and outlet of the outdoor unit is blocked with snow, it might become difficult to get warm, and it is likely to cause product malfunction. Construct a canopy and a pedestal, or place the unit on a high stand that is locally installed.

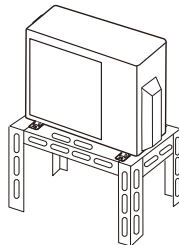

3-2. Models: AOYG30LBTA and AOYG36LBTA

■ Space requirement

Provide sufficient installation space for product safety.

● Single outdoor unit installation

- When the upper space is open:

Unit: mm

When there are obstacles at the rear only.

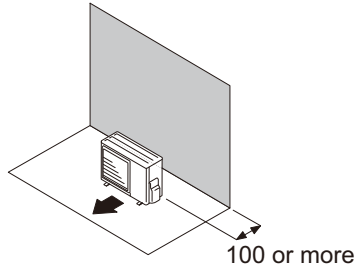

When there are obstacles at the rear and sides.

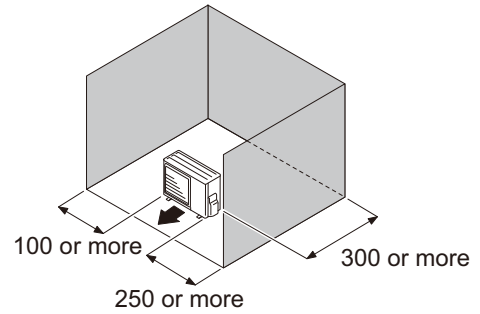

When there are obstacles at the front only.

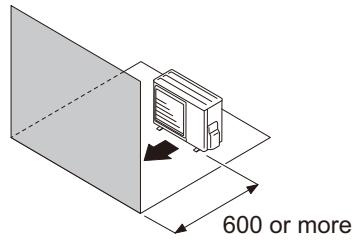

When there are obstacles at the front and rear.

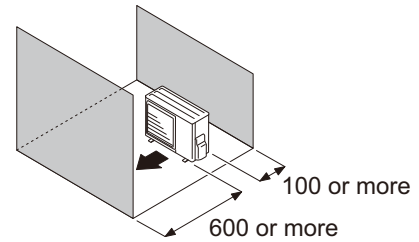

- When there is an obstruction in the upper space:

Unit: mm

When there are obstacles at the rear and above.

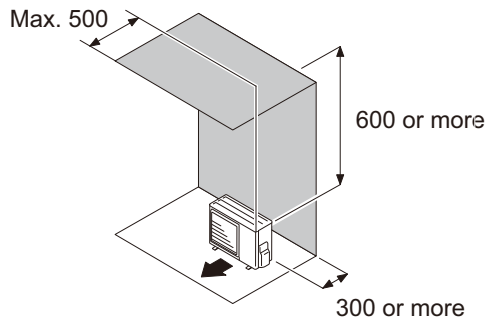

When there are obstacles at the rear, sides, and above.

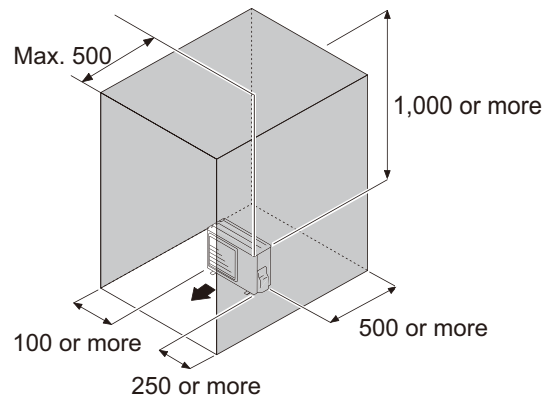

● Multiple outdoor unit installation

- When the upper space is open:

Unit: mm

When there are obstacles at the rear only.

When there are obstacles at the front only.

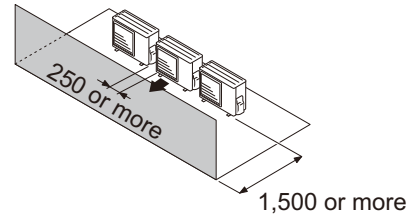
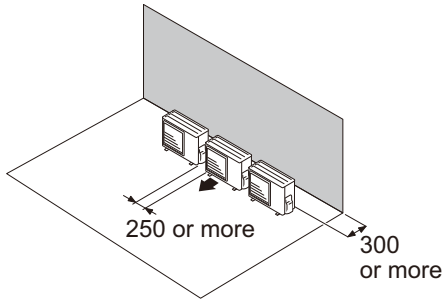

When there are obstacles at the front and rear.

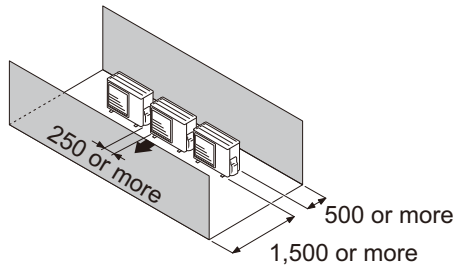

- When there is an obstruction in the upper space:

Unit: mm

When there are obstacles at the rear and above.

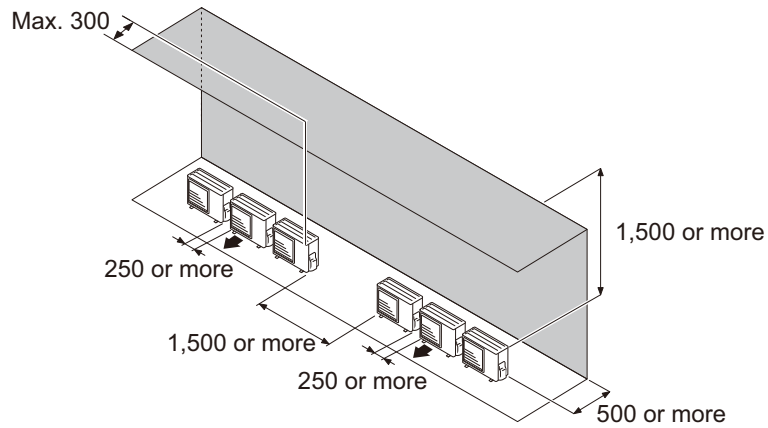

● Outdoor unit installation in multi-row

Unit: mm

Single parallel unit arrangement

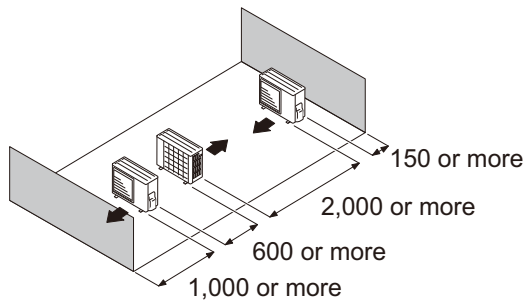

Multiple parallel unit arrangement

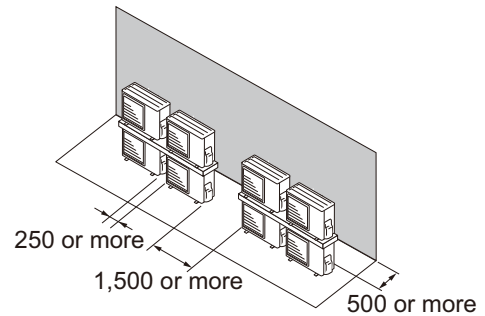
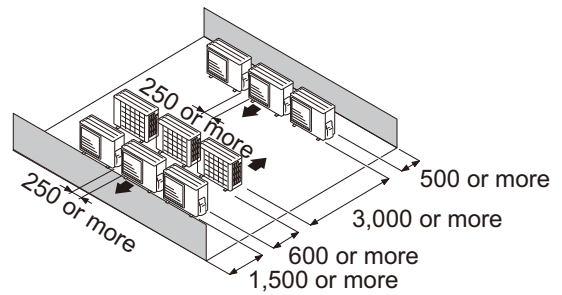

NOTES:

- If the space is larger than stated above, the condition will be the same as when there is no obstacle.
- Height above the floor level should be 50 mm or more.
- When installing the outdoor unit, be sure to open the front and left side to obtain better operation efficiency.

⚠ CAUTION

- Do not install the outdoor unit in two-stage where the drain water could freeze. Otherwise the drainage from the upper unit may form ice and cause a malfunction of the lower unit.
- When the outdoor temperature is 0 °C or less, do not use the accessory drain pipe and drain cap. If the drain pipe and drain cap are used, the drain water in the pipe may freeze in extremely cold climate. (For reverse cycle model only.)
- In area with heavy snowfall, if the inlet and outlet of the outdoor unit is blocked with snow, it might become difficult to get warm, and it is likely to cause product malfunction. Construct a canopy and a pedestal, or place the unit on a high stand that is locally installed.

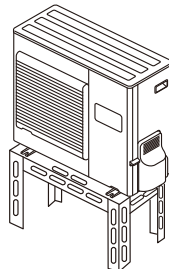

3-3. Models: AOYG45LBTA and AOYG54LBTA

OUTDOOR UNIT
AOYG18-54LB

■ Space requirement

Provide sufficient installation space for product safety.

● Single outdoor unit installation

- When the upper space is open:

Unit: mm

When there are obstacles at the rear only.

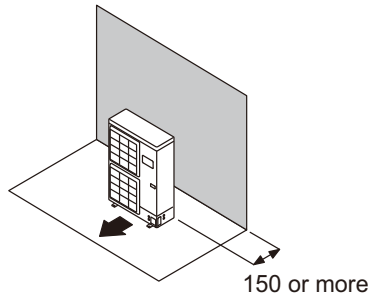

When there are obstacles at the rear and sides.

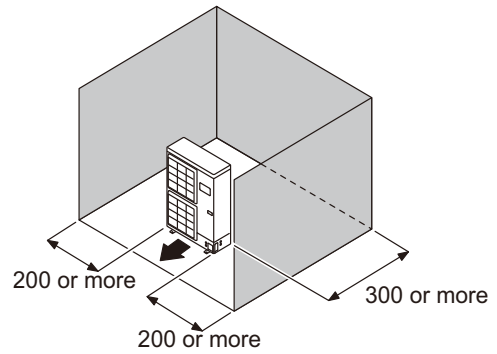

When there are obstacles at the front only.

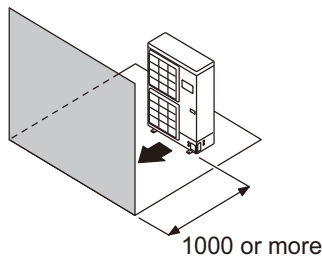

When there are obstacles at the front and rear.

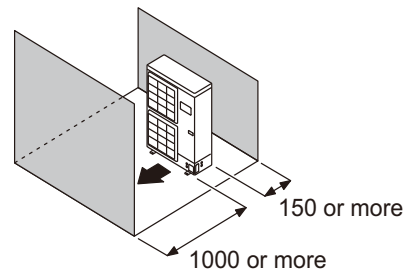

- When there is an obstruction in the upper space:

Unit: mm

When there are obstacles at the rear and above.

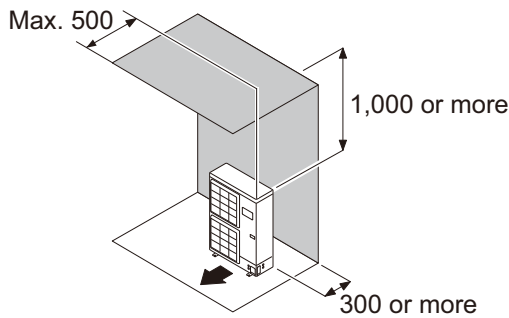

When there are obstacles at the rear, sides, and above.

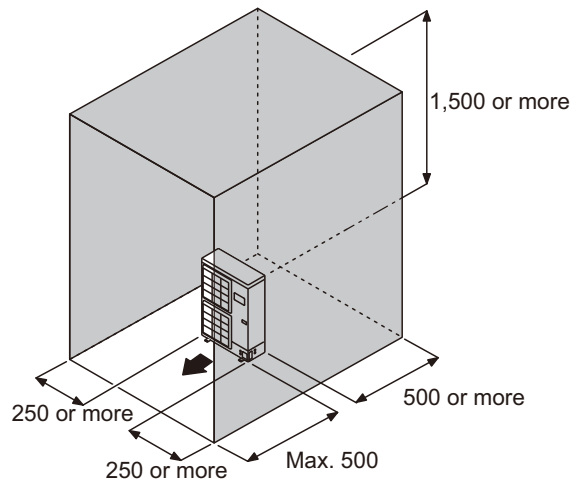

● Multiple outdoor unit installation

- When the upper space is open:

Unit: mm

When there are obstacles at the rear only.

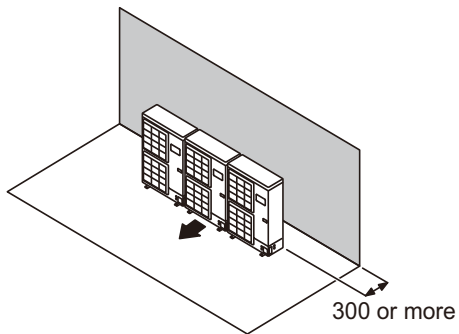

When there are obstacles at the front only.

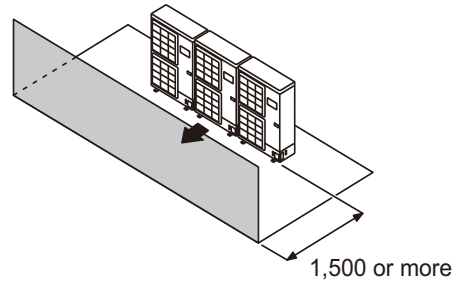

When there are obstacles at the front and rear.

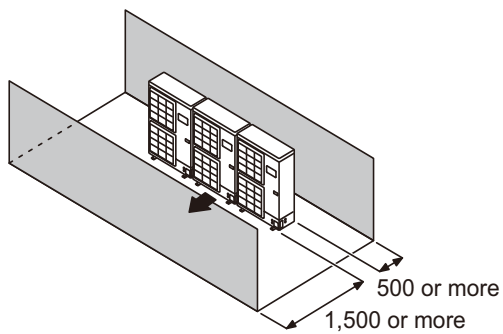

- When there is an obstruction in the upper space:

Unit: mm

When there are obstacles at the rear and above.

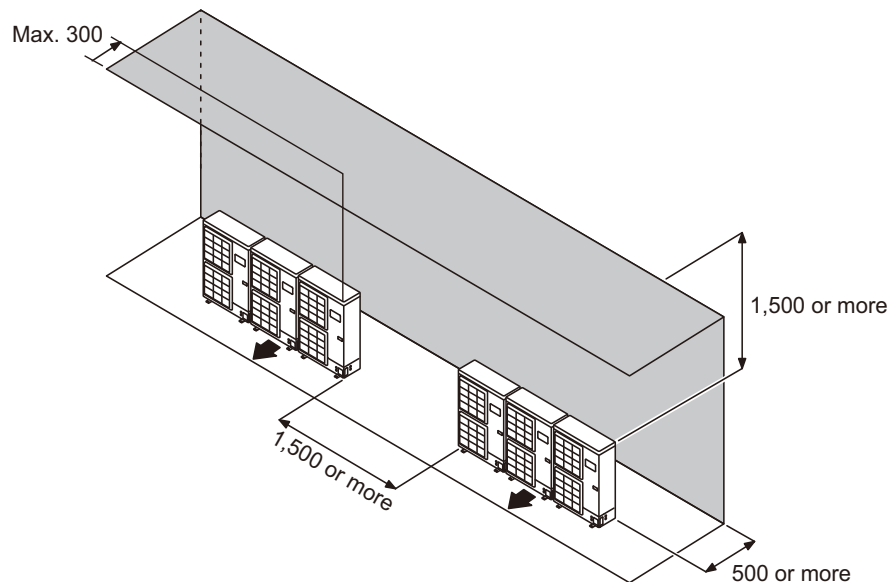

● Outdoor unit installation in multi-row

Unit: mm

Single parallel unit arrangement

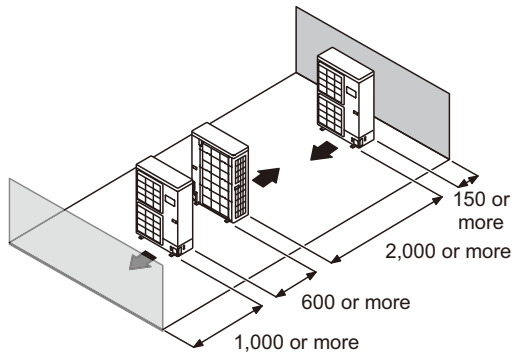

Multiple parallel unit arrangement

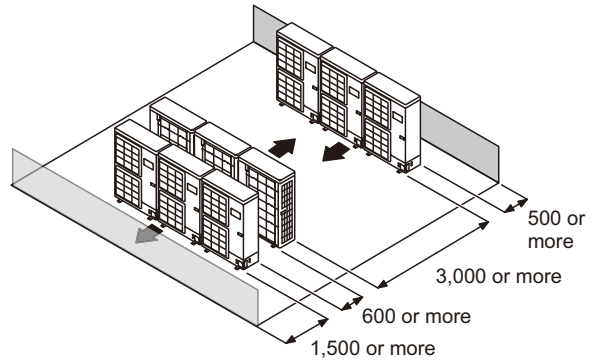

NOTES:

- If the space is larger than stated above, the condition will be the same as when there is no obstacle.
- Height above the floor level should be 50 mm or more.
- When installing the outdoor unit, be sure to open the front and left side to obtain better operation efficiency.

⚠ CAUTION

- When the outdoor temperature is 0 °C or less, do not use the accessory drain pipe and drain cap. If the drain pipe and drain cap are used, the drain water in the pipe may freeze in extremely cold climate. (For reverse cycle model only.)
- In area with heavy snowfall, if the inlet and outlet of the outdoor unit is blocked with snow, it might become difficult to get warm, and it is likely to cause product malfunction. Construct a canopy and a pedestal, or place the unit on a high stand that is locally installed.

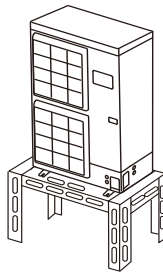

4. Refrigerant circuit

4-1. Models: AOYG18LBCA and AOYG24LBCA

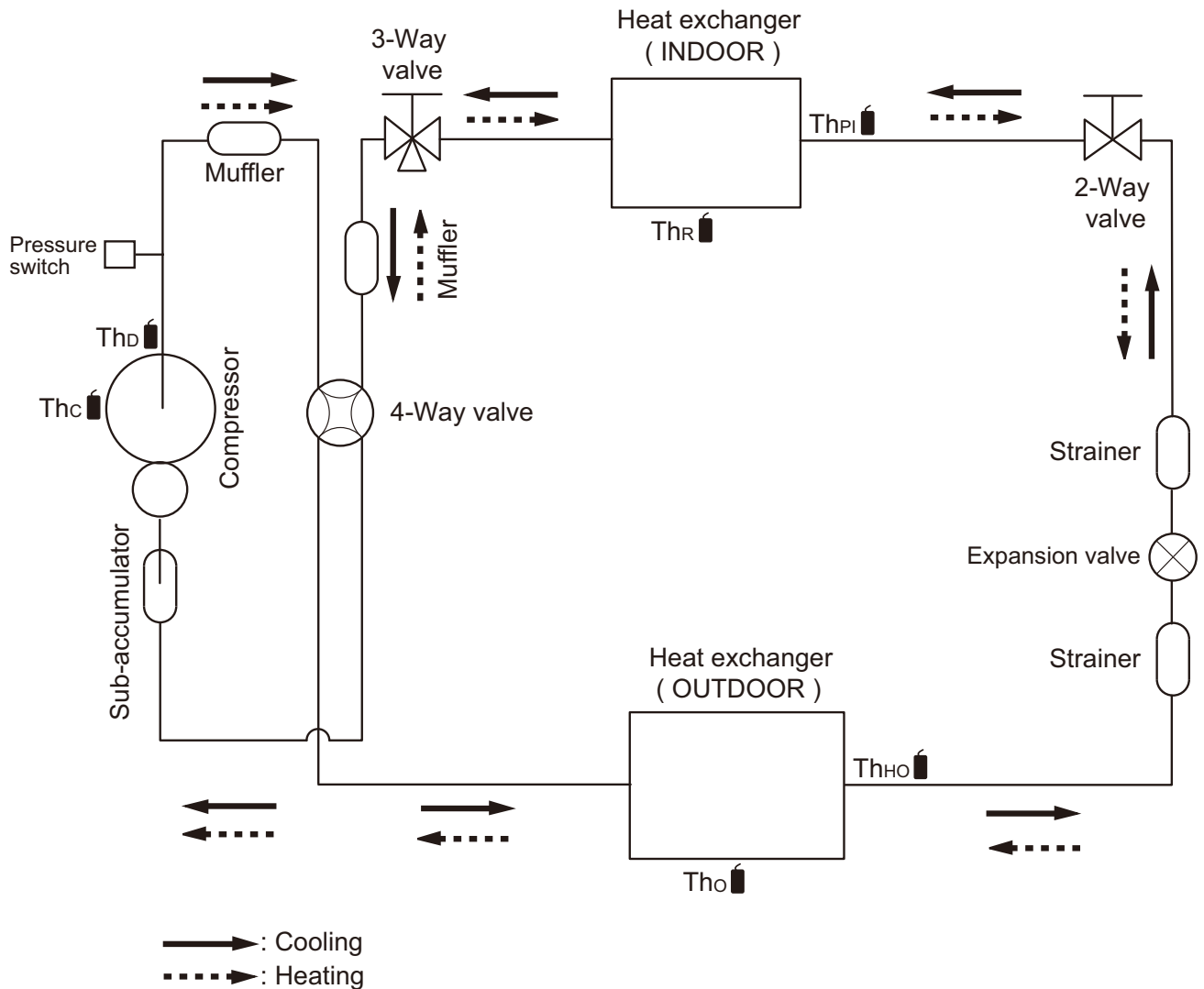

Th_c : Thermistor (Compressor Temp.)

Th_d : Thermistor (Discharge Temp.)

Th_o : Thermistor (Outdoor Temp.)

Th_{HO} : Thermistor (Heat Exchanger Out Temp.)

Th_R : Thermistor (Room Temp.)

Th_{PI} : Thermistor (Pipe Temp.)

4-2. Models: AOYG30LBTA and AOYG36LBTA

OUTDOOR UNIT
AOYG18-54LB

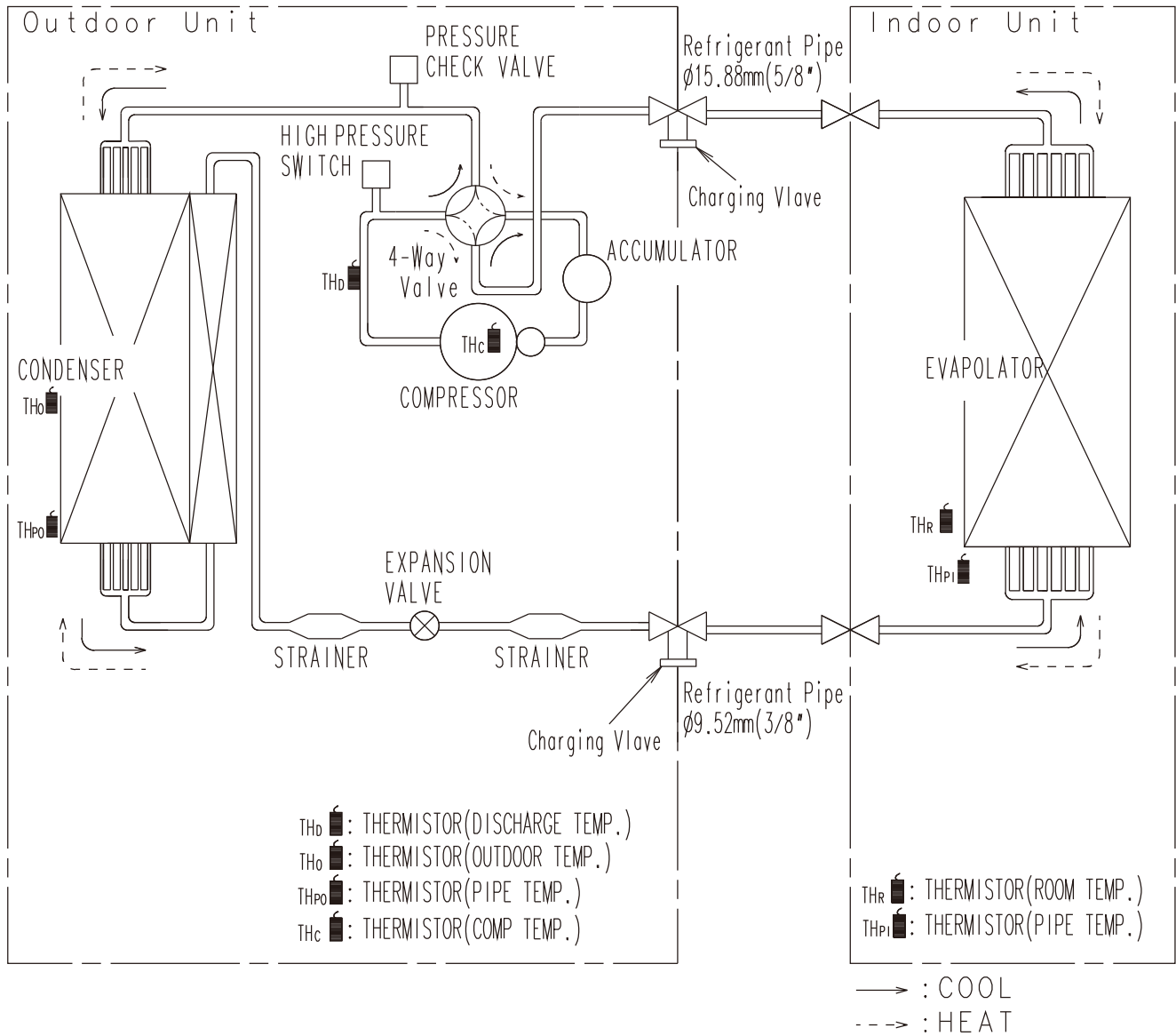

4-3. Models: AOYG45LBTA and AOYG54LBTA

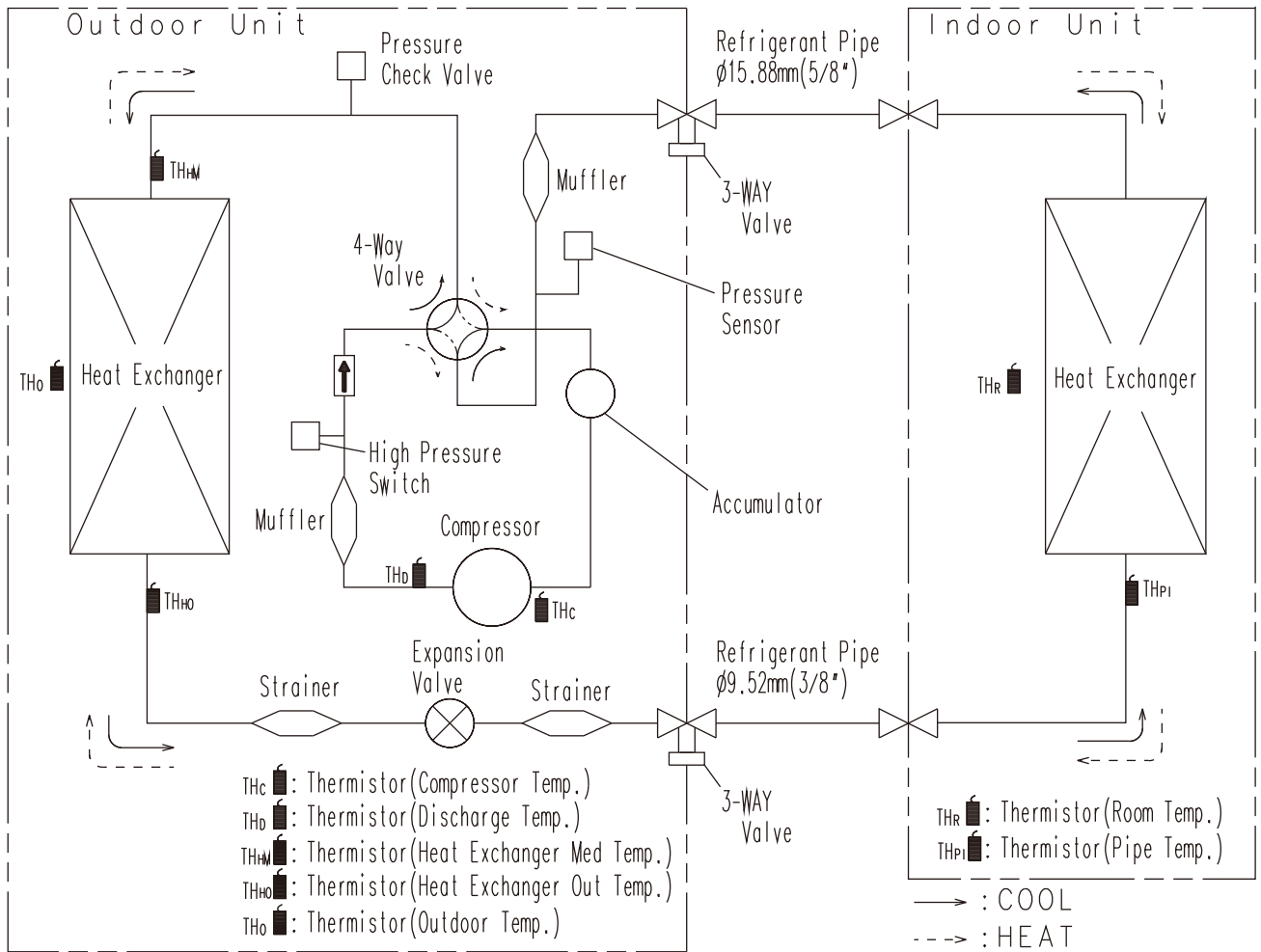

OUTDOOR UNIT
AOYG18-54LB

5. Wiring diagrams

5-1. Models: AOYG18LBCA and AOYG24LBCA

OUTDOOR UNIT
AOYG18-54LB

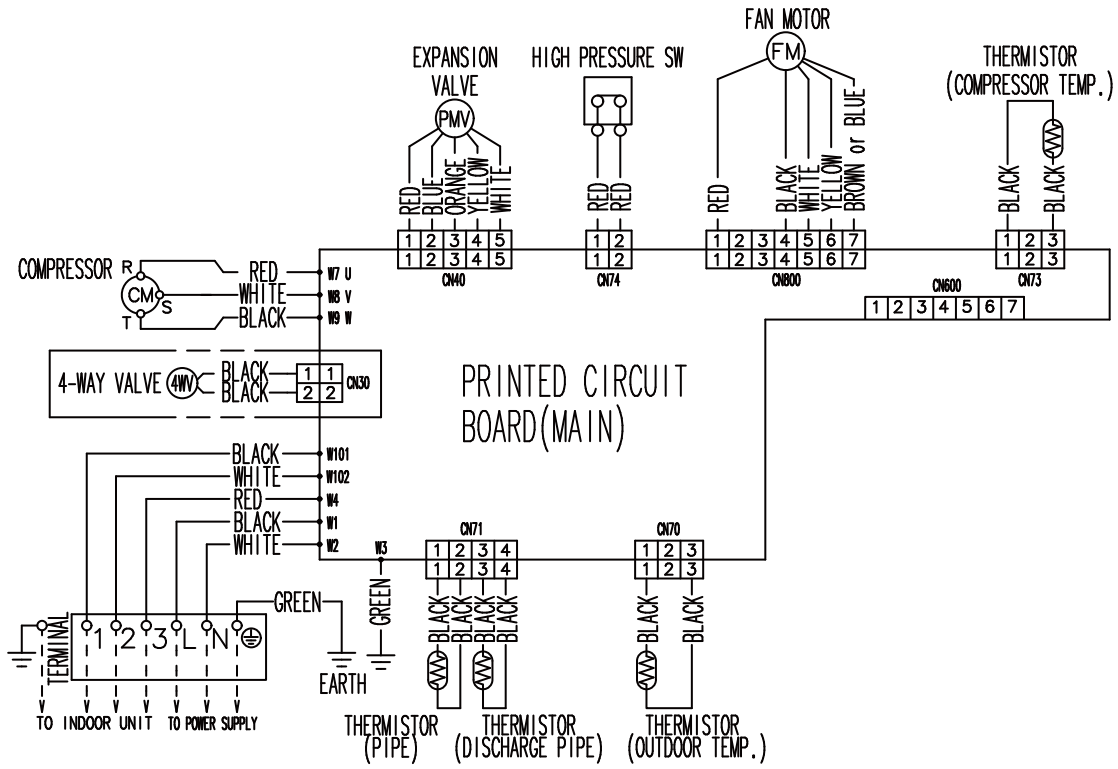

5-2. Model: AOYG30LBTA

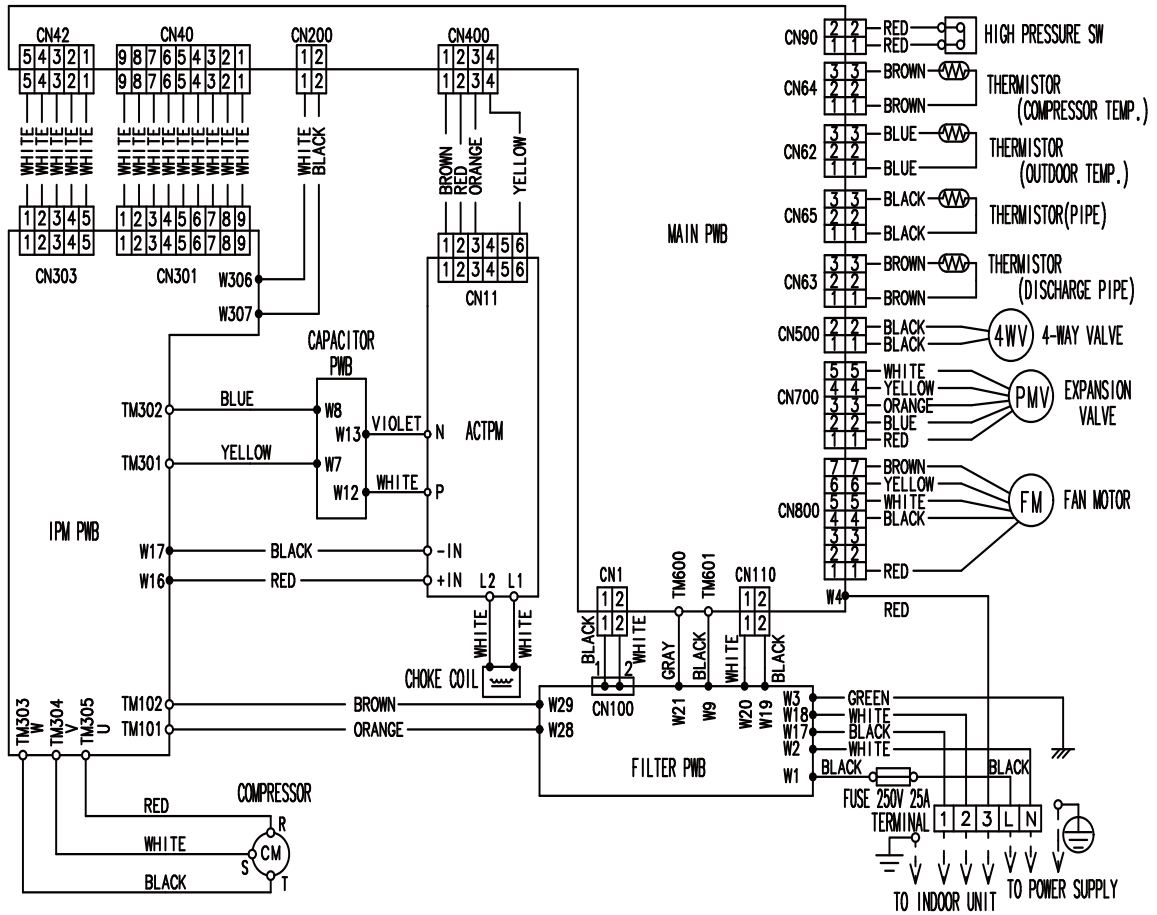

OUTDOOR UNIT
AOYG18-54LB

5-3. Model: AOYG36LBTA

OUTDOOR UNIT
AOYG18-54LB

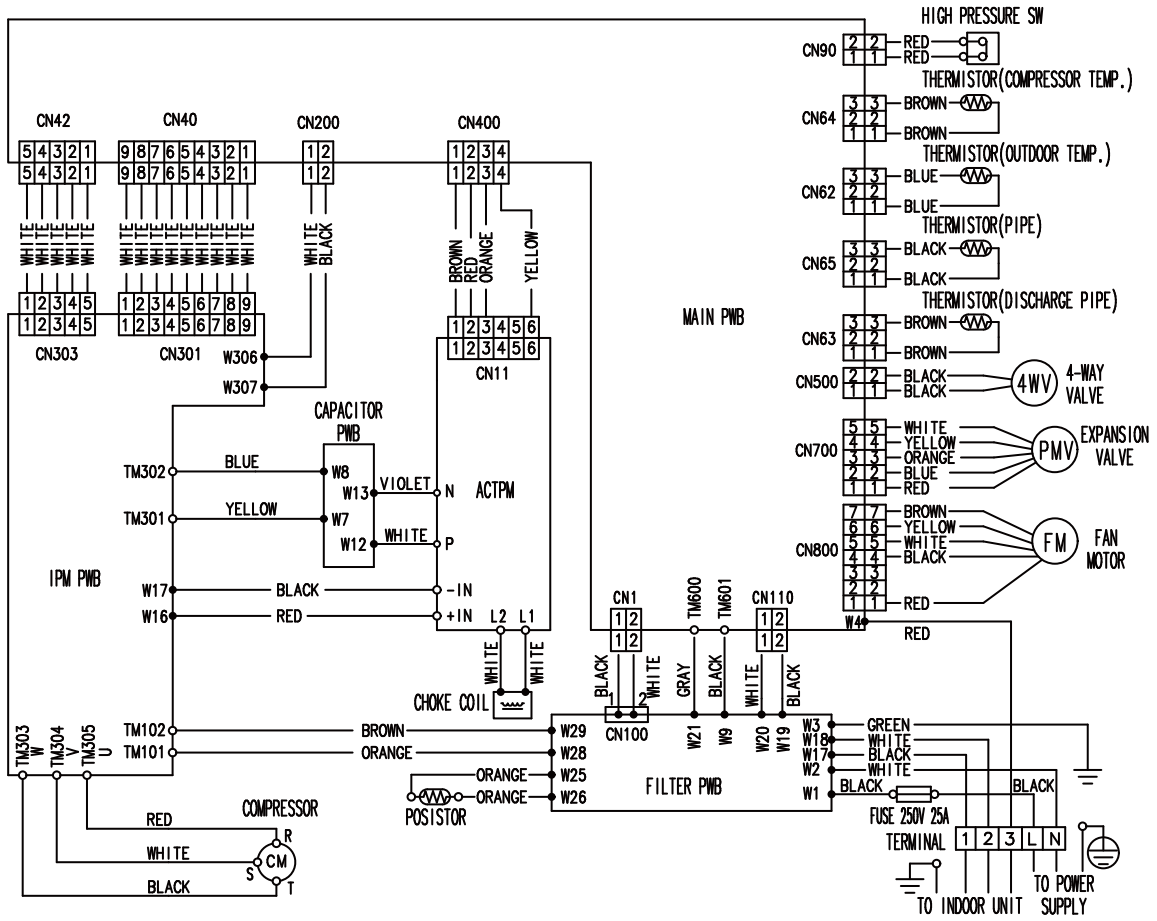

5-4. Models: AOYG45LBTA and AOYG54LBTA

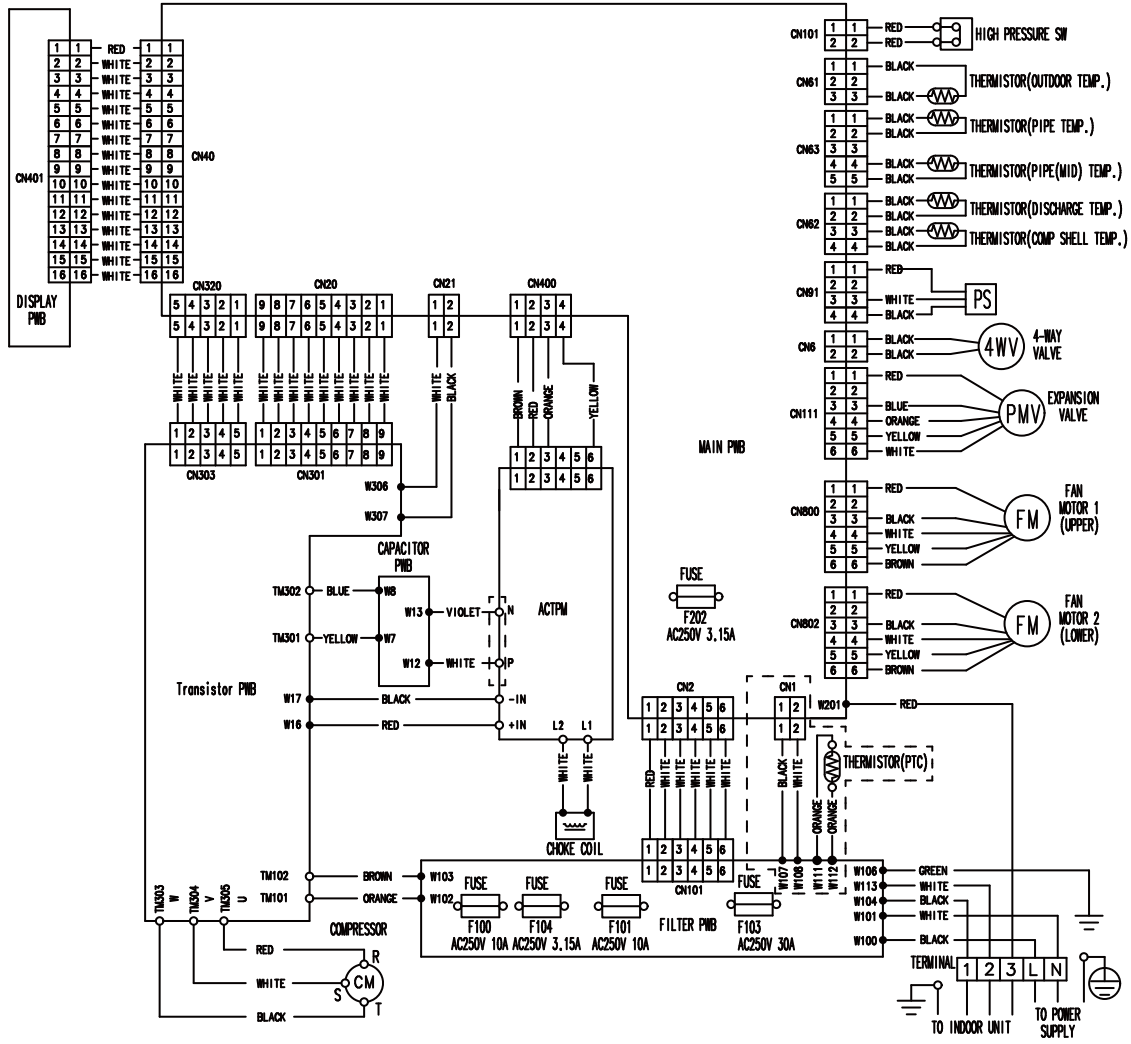

OUTDOOR UNIT
AOYG18-54LB

6. Capacity compensation rate for pipe length and height difference

OUTDOOR UNIT
AOYG18-54LB

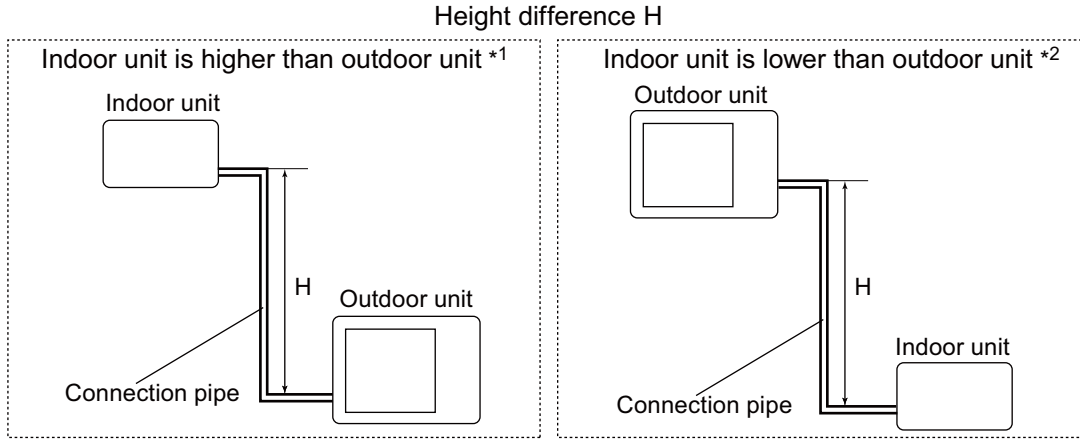

6-1. Model: AOYG18LBCA

NOTE: Values mentioned in the table are calculated based on the maximum capacity.

COOLING			Pipe length (m)				
			5	7.5	10	20	30
Height difference H (m)	Indoor unit is higher than outdoor unit *1	20	-	-	-	0.952	0.951
		10	-	-	0.980	0.968	0.966
		7.5	-	0.988	0.984	0.972	0.970
		5	0.995	0.992	0.988	0.976	0.974
	Indoor unit is lower than outdoor unit *2	0	1.003	1.000	0.996	0.983	0.982
		-5	1.003	1.000	0.996	0.983	0.982
		-7.5	-	1.000	0.996	0.983	0.982
		-10	-	-	0.996	0.983	0.982
	-20	-	-	-	0.983	0.982	

HEATING			Pipe length (m)				
			5	7.5	10	20	30
Height difference H (m)	Indoor unit is higher than outdoor unit *1	20	-	-	-	0.954	0.908
		10	-	-	0.998	0.954	0.908
		7.5	-	1.000	0.998	0.954	0.908
		5	0.989	1.000	0.998	0.954	0.908
	Indoor unit is lower than outdoor unit *2	0	0.989	1.000	0.998	0.954	0.908
		-5	0.984	0.995	0.993	0.950	0.903
		-7.5	-	0.993	0.991	0.947	0.901
		-10	-	-	0.988	0.945	0.899
	-20	-	-	-	0.935	0.890	

6-2. Model: AOYG24LBCA

NOTE: Values mentioned in the table are calculated based on the maximum capacity.

COOLING			Pipe length (m)				
			5	7.5	10	20	30
Height difference H (m)	Indoor unit is higher than outdoor unit *1	20	-	-	-	0.952	0.951
		10	-	-	0.980	0.968	0.966
		7.5	-	0.988	0.984	0.972	0.970
		5	0.995	0.992	0.988	0.976	0.974
		0	1.003	1.000	0.996	0.983	0.982
	Indoor unit is lower than outdoor unit *2	-5	1.003	1.000	0.996	0.983	0.982
		-7.5	-	1.000	0.996	0.983	0.982
		-10	-	-	0.996	0.983	0.982
-20		-	-	-	0.983	0.982	

HEATING			Pipe length (m)				
			5	7.5	10	20	30
Height difference H (m)	Indoor unit is higher than outdoor unit *1	20	-	-	-	0.954	0.908
		10	-	-	0.998	0.954	0.908
		7.5	-	1.000	0.998	0.954	0.908
		5	0.989	1.000	0.998	0.954	0.908
		0	0.989	1.000	0.998	0.954	0.908
	Indoor unit is lower than outdoor unit *2	-5	0.984	0.995	0.993	0.950	0.903
		-7.5	-	0.993	0.991	0.947	0.901
		-10	-	-	0.988	0.945	0.899
-20		-	-	-	0.935	0.890	

6-3. Model: AOYG30LBTA

NOTE: Values mentioned in the table are calculated based on the maximum capacity.

COOLING			Pipe length (m)						
			5	7.5	10	20	30	40	50
Height difference H (m)	Indoor unit is higher than outdoor unit *1	30	-	-	-	-	0.908	0.894	0.876
		20	-	-	-	0.935	0.923	0.909	0.891
		10	-	-	0.968	0.951	0.938	0.924	0.906
		7.5	-	0.982	0.972	0.954	0.942	0.928	0.909
		5	0.992	0.986	0.976	0.958	0.946	0.932	0.913
	Indoor unit is lower than outdoor unit *2	0	1.000	0.994	0.983	0.966	0.954	0.939	0.920
		-5	1.000	0.994	0.983	0.966	0.954	0.939	0.920
		-7.5	-	0.994	0.983	0.966	0.954	0.939	0.920
		-10	-	-	0.983	0.966	0.954	0.939	0.920
		-20	-	-	-	0.966	0.954	0.939	0.920
	-30	-	-	-	-	0.954	0.939	0.920	

HEATING			Pipe length (m)						
			5	7.5	10	20	30	40	50
Height difference H (m)	Indoor unit is higher than outdoor unit *1	30	-	-	-	-	0.931	0.914	0.899
		20	-	-	-	0.954	0.931	0.914	0.899
		10	-	-	0.990	0.954	0.931	0.914	0.899
		7.5	-	0.991	0.990	0.954	0.931	0.914	0.899
		5	1.000	0.991	0.990	0.954	0.931	0.914	0.899
	Indoor unit is lower than outdoor unit *2	0	1.000	0.991	0.990	0.954	0.931	0.914	0.899
		-5	0.995	0.986	0.986	0.949	0.926	0.909	0.895
		-7.5	-	0.983	0.983	0.946	0.924	0.907	0.892
		-10	-	-	0.981	0.944	0.921	0.904	0.890
		-20	-	-	-	0.935	0.912	0.895	0.881
	-30	-	-	-	-	0.903	0.886	0.872	

OUTDOOR UNIT
AOYG18-54LB

6-4. Model: AOYG36LBTA

NOTE: Values mentioned in the table are calculated based on the maximum capacity.

COOLING			Pipe length (m)						
			5	7.5	10	20	30	40	50
Height difference H (m)	Indoor unit is higher than outdoor unit *1	30	-	-	-	-	0.908	0.894	0.876
		20	-	-	-	0.935	0.923	0.909	0.891
		10	-	-	0.968	0.951	0.938	0.924	0.906
		7.5	-	0.982	0.972	0.954	0.942	0.928	0.909
		5	0.992	0.986	0.976	0.958	0.946	0.932	0.913
	Indoor unit is lower than outdoor unit *2	0	1.000	0.994	0.983	0.966	0.954	0.939	0.920
		-5	1.000	0.994	0.983	0.966	0.954	0.939	0.920
		-7.5	-	0.994	0.983	0.966	0.954	0.939	0.920
		-10	-	-	0.983	0.966	0.954	0.939	0.920
		-20	-	-	-	0.966	0.954	0.939	0.920
	-30	-	-	-	-	0.954	0.939	0.920	

HEATING			Pipe length (m)						
			5	7.5	10	20	30	40	50
Height difference H (m)	Indoor unit is higher than outdoor unit *1	30	-	-	-	-	0.931	0.914	0.899
		20	-	-	-	0.954	0.931	0.914	0.899
		10	-	-	0.990	0.954	0.931	0.914	0.899
		7.5	-	0.991	0.990	0.954	0.931	0.914	0.899
		5	1.000	0.991	0.990	0.954	0.931	0.914	0.899
	Indoor unit is lower than outdoor unit *2	0	1.000	0.991	0.990	0.954	0.931	0.914	0.899
		-5	0.995	0.986	0.986	0.949	0.926	0.909	0.895
		-7.5	-	0.983	0.983	0.946	0.924	0.907	0.892
		-10	-	-	0.981	0.944	0.921	0.904	0.890
		-20	-	-	-	0.935	0.912	0.895	0.881
	-30	-	-	-	-	0.903	0.886	0.872	

6-5. Model: AOYG45LBTA

NOTE: Values mentioned in the table are calculated based on the maximum capacity.

COOLING			Pipe length (m)						
			5	7.5	10	20	30	40	50
Height difference H (m)	Indoor unit is higher than outdoor unit *1	30	-	-	-	-	0.879	0.846	0.814
		20	-	-	-	0.926	0.893	0.861	0.828
		10	-	-	0.975	0.942	0.908	0.875	0.841
		7.5	-	0.988	0.979	0.946	0.912	0.878	0.845
		5	0.992	0.992	0.983	0.949	0.916	0.882	0.848
	Indoor unit is lower than outdoor unit *2	0	1.000	1.000	0.991	0.957	0.923	0.889	0.855
		-5	1.000	1.000	0.991	0.957	0.923	0.889	0.855
		-7.5	-	1.000	0.991	0.957	0.923	0.889	0.855
		-10	-	-	0.991	0.957	0.923	0.889	0.855
		-20	-	-	-	0.957	0.923	0.889	0.855
	-30	-	-	-	-	0.923	0.889	0.855	

HEATING			Pipe length (m)						
			5	7.5	10	20	30	40	50
Height difference H (m)	Indoor unit is higher than outdoor unit *1	30	-	-	-	-	0.978	0.968	0.958
		20	-	-	-	0.988	0.978	0.968	0.958
		10	-	-	0.998	0.988	0.978	0.968	0.958
		7.5	-	1.000	0.998	0.988	0.978	0.968	0.958
		5	1.000	1.000	0.998	0.988	0.978	0.968	0.958
	Indoor unit is lower than outdoor unit *2	0	1.000	1.000	0.998	0.988	0.978	0.968	0.958
		-5	0.998	0.995	0.993	0.983	0.973	0.963	0.953
		-7.5	-	0.993	0.991	0.981	0.971	0.961	0.951
		-10	-	-	0.988	0.978	0.968	0.958	0.948
		-20	-	-	-	0.968	0.958	0.949	0.939
	-30	-	-	-	-	0.949	0.939	0.929	

6-6. Model: AOYG54LBTA

NOTE: Values mentioned in the table are calculated based on the maximum capacity.

COOLING			Pipe length (m)						
			5	7.5	10	20	30	40	50
Height difference H (m)	Indoor unit is higher than outdoor unit *1	30	-	-	-	-	0.871	0.837	0.803
		20	-	-	-	0.921	0.886	0.851	0.816
		10	-	-	0.971	0.936	0.900	0.865	0.830
		7.5	-	0.988	0.975	0.940	0.904	0.868	0.833
		5	0.992	0.992	0.979	0.943	0.908	0.872	0.836
	Indoor unit is lower than outdoor unit *2	0	1.000	1.000	0.987	0.951	0.915	0.879	0.843
		-5	1.000	1.000	0.987	0.951	0.915	0.879	0.843
		-7.5	-	1.000	0.987	0.951	0.915	0.879	0.843
		-10	-	-	0.987	0.951	0.915	0.879	0.843
		-20	-	-	-	0.951	0.915	0.879	0.843
	-30	-	-	-	-	0.915	0.879	0.843	

HEATING			Pipe length (m)						
			5	7.5	10	20	30	40	50
Height difference H (m)	Indoor unit is higher than outdoor unit *1	30	-	-	-	-	0.978	0.968	0.958
		20	-	-	-	0.988	0.978	0.968	0.958
		10	-	-	0.998	0.988	0.978	0.968	0.958
		7.5	-	1.000	0.998	0.988	0.978	0.968	0.958
		5	1.000	1.000	0.998	0.988	0.978	0.968	0.958
	Indoor unit is lower than outdoor unit *2	0	1.000	1.000	0.998	0.988	0.978	0.968	0.958
		-5	0.998	0.995	0.993	0.983	0.973	0.963	0.953
		-7.5	-	0.993	0.991	0.981	0.971	0.961	0.951
		-10	-	-	0.988	0.978	0.968	0.958	0.948
		-20	-	-	-	0.968	0.958	0.949	0.939
	-30	-	-	-	-	0.949	0.939	0.929	

7. Additional charge calculation

7-1. Models: AOYG18LBCA and AOYG24LBCA

Refrigerant type	R410A	
Refrigerant amount	g	1,800

■ Refrigerant charge

Total pipe length	m	15 or less	20	30 (Max.)	20 g/m
Additional charge	g	0	100	300	

7-2. Models: AOYG30LBTA and AOYG36LBTA

Refrigerant type	R410A	
Refrigerant amount	g	2,100

■ Refrigerant charge

Total pipe length	m	20 or less	30	40	50 (Max.)	40 g/m
Additional charge	g	0	400	800	1,200	

7-3. Models: AOYG45LBTA and AOYG54LBTA

Refrigerant type	R410A	
Refrigerant amount	g	3,350

■ Refrigerant charge

Total pipe length	m	20 or less	30	40	50 (Max.)	40 g/m
Additional charge	g	0	400	800	1,200	

8. Airflow

8-1. Model: AOYG18LBCA

● Cooling

m ³ /h	1,900
l/s	528
CFM	1,118

● Heating

m ³ /h	1,700
l/s	472
CFM	1,001

8-2. Model: AOYG24LBCA

● Cooling

m ³ /h	2,460
l/s	683
CFM	1,448

● Heating

m ³ /h	2,340
l/s	650
CFM	1,377

8-3. Model: AOYG30LBTA

● Cooling

m ³ /h	3,600
l/s	1,000
CFM	2,119

● Heating

m ³ /h	3,600
l/s	1,000
CFM	2,119

8-4. Model: AOYG36LBTA

● Cooling

m ³ /h	3,800
l/s	1,056
CFM	2,237

● Heating

m ³ /h	3,800
l/s	1,056
CFM	2,237

8-5. Model: AOYG45LBTA

● Cooling

m ³ /h	6,750
l/s	1,875
CFM	3,973

● Heating

m ³ /h	6,200
l/s	1,722
CFM	3,649

8-6. Model: AOYG54LBTA

● Cooling

m ³ /h	6,750
l/s	1,875
CFM	3,973

● Heating

m ³ /h	6,850
l/s	1,903
CFM	4,032

9. Operation noise (sound pressure)

9-1. Noise level curve

Model: AOYG18LBCA

Cooling

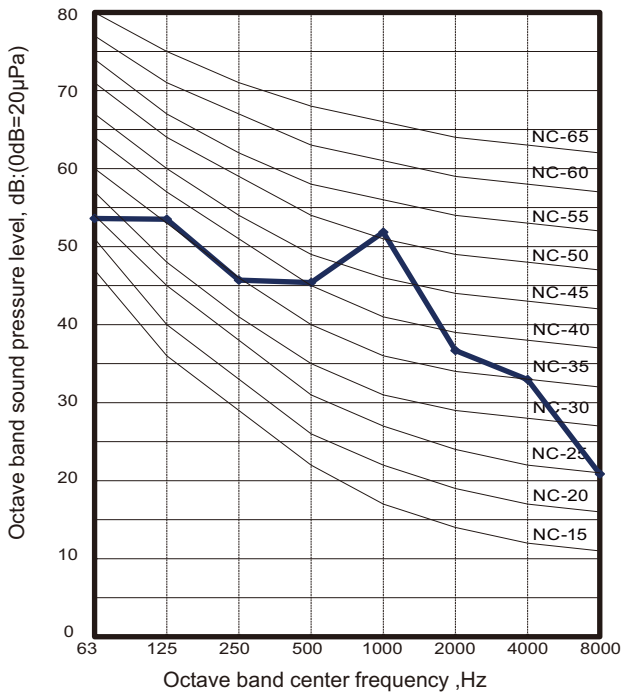

Heating

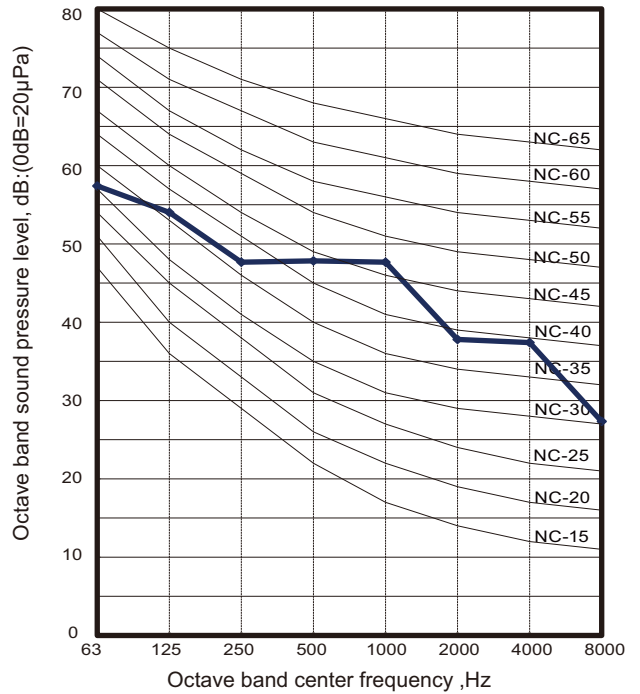

Model: AOYG24LBCA

Cooling

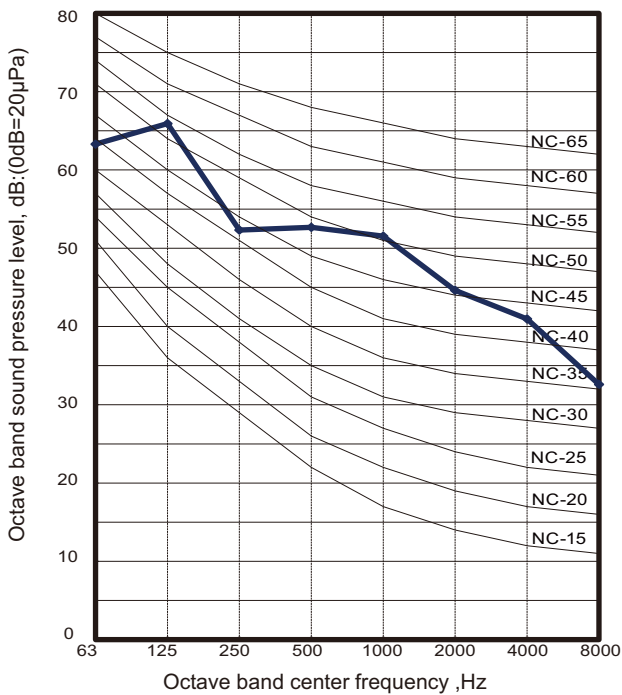

Heating

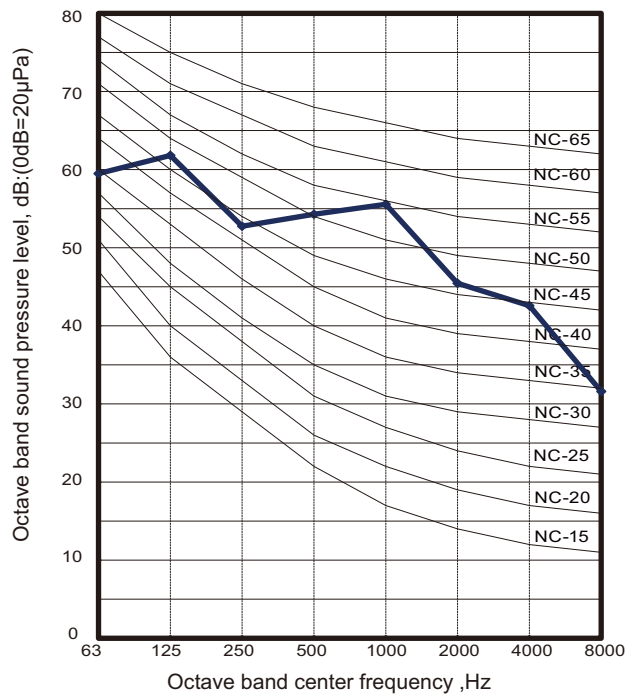

OUTDOOR UNIT
AOYG18-54LB

Model: AOYG30LBTA

OUTDOOR UNIT
AOYG18-54LB

Cooling

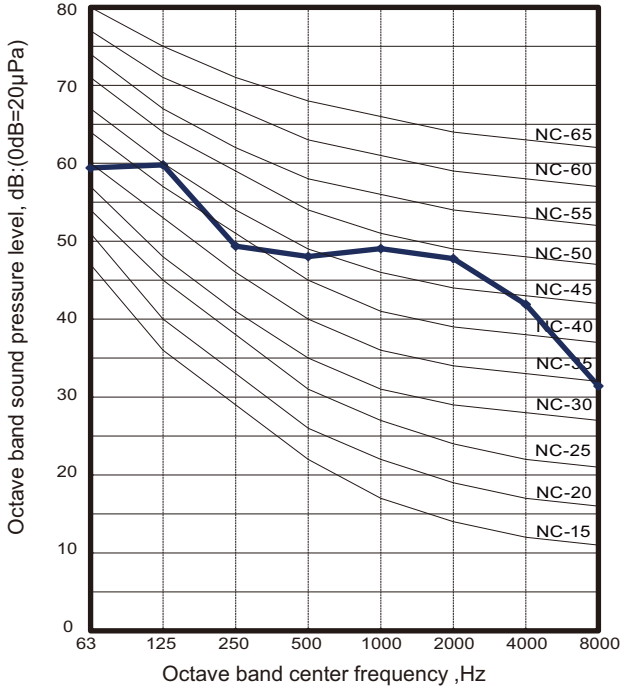

Heating

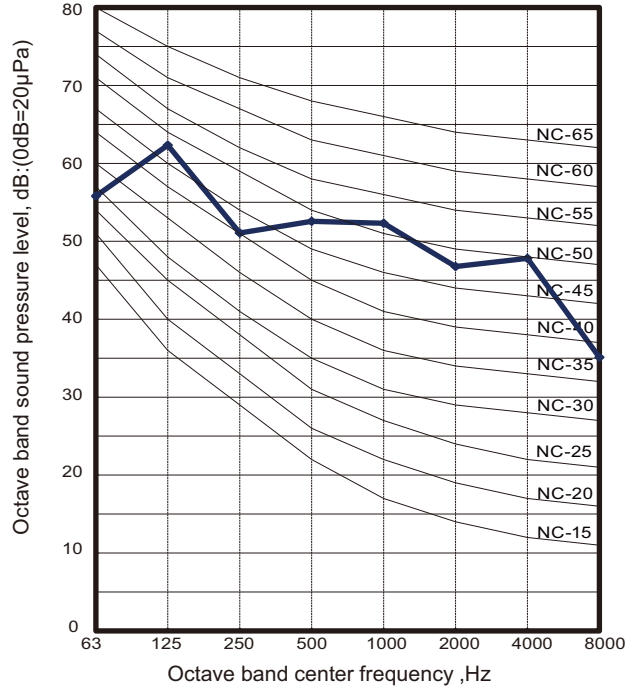

Model: AOYG36LBTA

Cooling

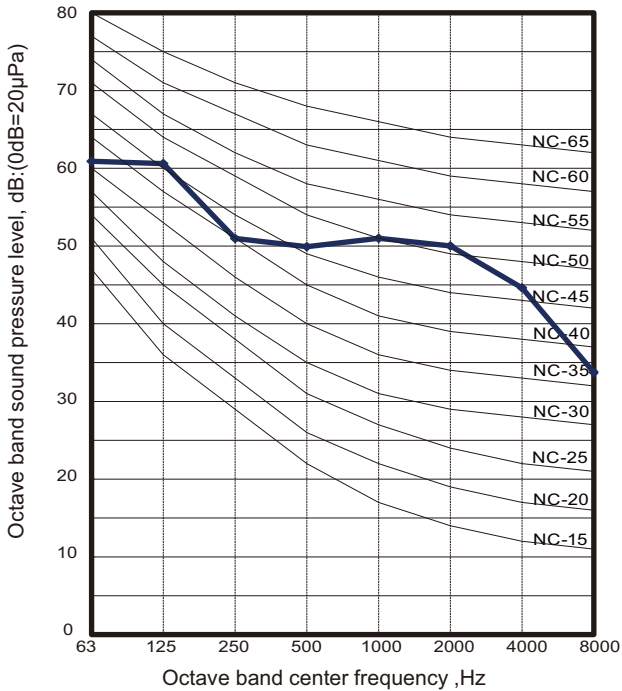

Heating

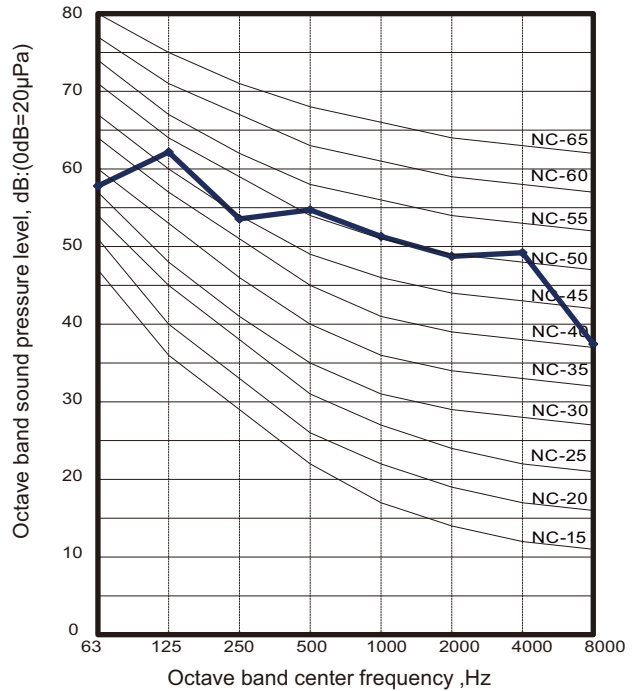

Model: AOYG45LBTA

Cooling

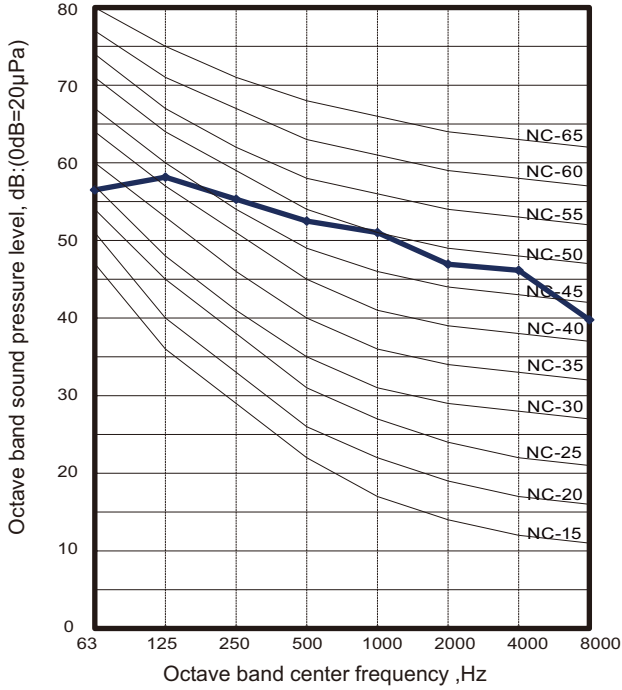

Heating

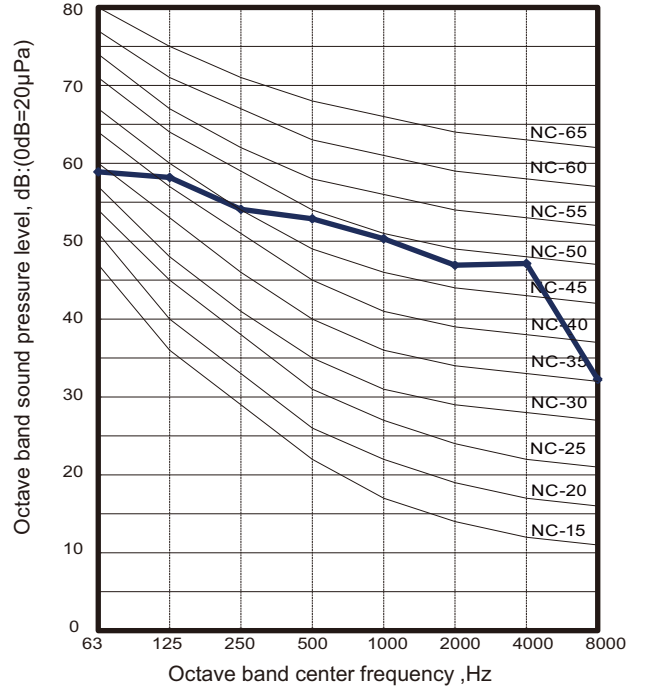

Model: AOYG54LBTA

Cooling

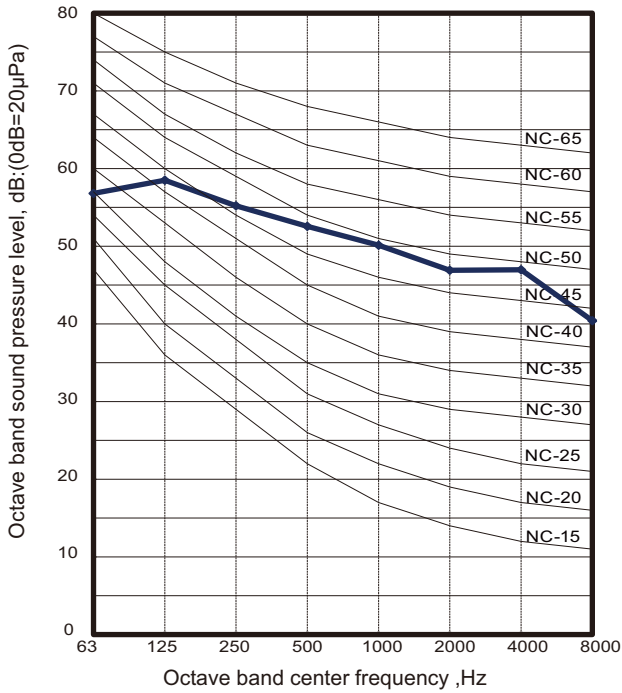

Heating

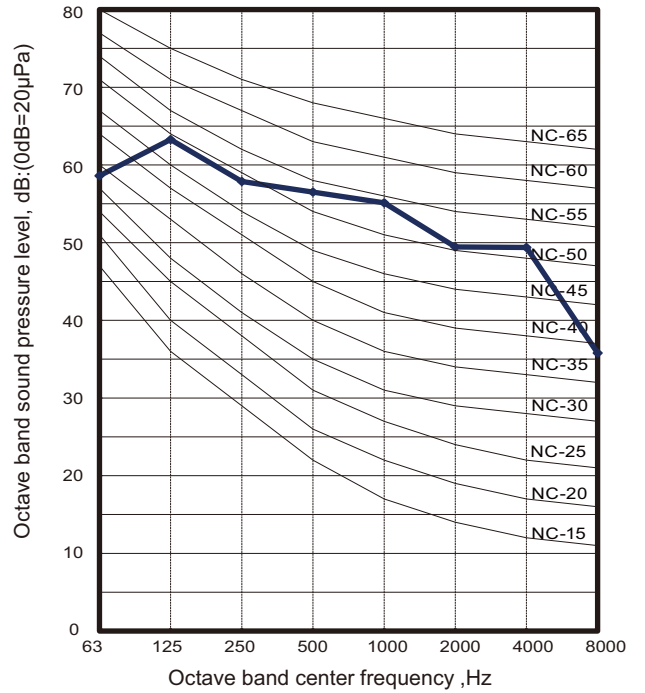

OUTDOOR UNIT
AOYG18-54LB

9-2. Sound level check point

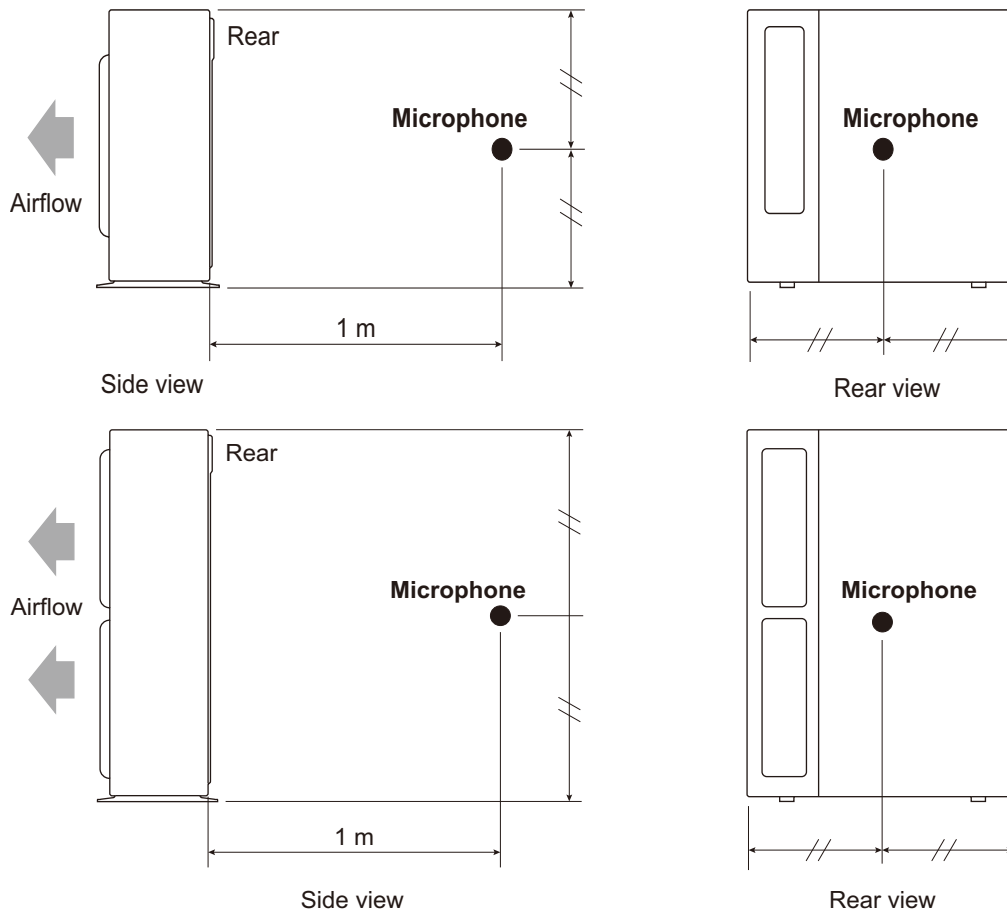

NOTE: Detailed shape of the actual outdoor unit might be slightly different from the one illustrated above.

10. Electrical characteristics

Model name			AOYG18LBCA	AOYG24LBCA
Power supply	Voltage	V	230	
	Frequency	Hz	50	
Max. operating current*1		A	13.5	18.5
Wiring spec. *2	Circuit breaker current	A	25	30
	Power cable	mm ²	4.0	
	Connection cable *3	mm ²	1.5—2.5	
	Limited wiring length	m	31	

Model name			AOYG30LBTA	AOYG36LBTA	AOYG45LBTA	AOYG54LBTA
Power supply	Voltage	V	230			
	Frequency	Hz	50			
Max. operating current*1		A	17.0	20.0	20.5	21.5
Wiring spec. *2	Circuit breaker current	A	30			
	Power cable	mm ²	4.0		6.0	
	Connection cable *3	mm ²	1.5—2.5			
	Limited wiring length	m	51			

*1: The maximum current is the total current of indoor unit and outdoor unit.

*2: Selected sample based on Japan Electrotechnical Standards and Codes Committee E0005. As the regulations of wire size and circuit breaker differ in each country or region, select appropriate devices complied to the regional standard.

*3: Limit voltage drop to less than 2%. Increase conductor size if voltage drop is 2% or more.

11. Safety devices

OUTDOOR UNIT
AOYG18-54LB

Type of protection	Protection form		Model	
			AOYG18LBCA	AOYG24LBCA
Circuit protection	Current fuse (Filter PCB)		250 V, 20 A 250 V, 5 A	
	Current fuse (Main PCB)		250 V, 3.15 A	
Fan motor protection	Thermal protection program	Activate	100±10°C Fan motor stop	
		Reset	95 ±10°C Fan motor restart	
Compressor protection	Terminal protection program (Compressor temp.)	Activate	108°C Compressor stop	
		Reset	80°C Compressor restart	
	Thermal protection program (Discharge temp.)	Activate	110°C Compressor stop	
		Reset	After 7 minutes Compressor restart	
High pressure protection	Pressure switch	Activate	4.2±0.1 MPa Compressor stop	
		Reset	3.2±0.15 MPa Compressor restart	
Low pressure protection	Pressure sensor	Activate	0.12 MPa Compressor stop	
		Reset	0.15 MPa Compressor restart	

Type of protection	Protection form		Model	
			AOYG30LBTA	AOYG36LBTA
Circuit protection	Current fuse (Near the terminal)		250 V, 25 A	
	Current fuse (Filter PCB)		250 V, 10 A	
	Current fuse (Main PCB)		250 V, 3.15 A	
Fan motor protection	Thermal protection program	Activate	150±15°C Fan motor stop	
		Reset	120±15°C Fan motor restart	
Compressor protection	Terminal protection program (Compressor temp.)	Activate	108°C Compressor stop	
		Reset	80°C Compressor restart	
	Thermal protection program (Discharge temp.)	Activate	110°C Compressor stop	
		Reset	After 7 minutes Compressor restart	
High pressure protection	Pressure switch	Activate	4.2±0.1 MPa Compressor stop	
		Reset	3.2±0.15 MPa Compressor restart	

Type of protection	Protection form		Model	
			AOYG45LBTA	AOYG54LBTA
Circuit protection	Current fuse (Filter PCB)		250 V, 30 A 250 V, 10 A × 2 250 V, 3.15 A	
	Current fuse (Main PCB)		250 V, 3.15 A	
Fan motor protection	Thermal protection program	Activate	112±9°C Fan motor stop	
		Reset	116 +10/-9°C Fan motor restart	
Compressor protection	Terminal protection program (Compressor temp.)	Activate	108°C Compressor stop	
		Reset	80°C Compressor restart	
	Thermal protection program (Discharge temp.)	Activate	110°C Compressor stop	
		Reset	After 7 minutes Compressor restart	
High pressure protection	Pressure switch	Activate	4.2±0.1 MPa Compressor stop	
		Reset	3.2±0.15 MPa Compressor restart	
Low pressure protection	Pressure sensor	Activate	0.12 MPa Compressor stop	
		Reset	0.15 MPa Compressor restart	

12. External input and output (Only for AOYG45LBTA and AOYG54LBTA)

With using external input and output functions, this product can be operated inter-connectedly with an external device.

Connector	Input	Output	Remarks
CN10	Low noise mode	—	See external input/output settings for details.
CN11	Peak cut mode	—	
CN12	—	Error status	
CN13	—	Compressor status	

12-1. External input

With using external input function, on/off status of “Low noise mode” and “Peak cut mode” can be specified by the external signal.

■ Low noise mode

In following condition, the operating noise of the outdoor unit reduces comparing from the one in normal operating condition:

The air conditioner is set to the “Low noise mode” when closing the contact input of a commercial timer or on/off switch to a connector on the control PCB of the outdoor unit.

NOTE: Product performance may drop depending on some conditions such as the outdoor temperature.

● Circuit diagram example

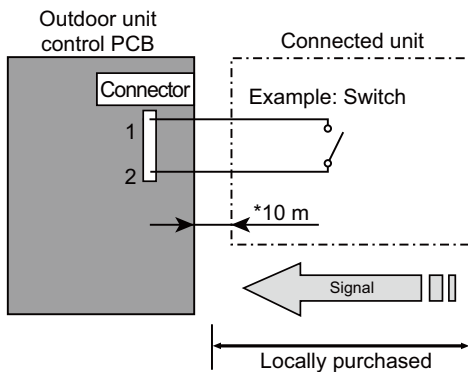

- Contact capacity: DC 24 V or more, 10 mA or more.
- *: Make the distance from the PCB to the connected unit within 10 m.
- Construct a circuit as shown in this figure with using optional parts mentioned below.
- Input signal: On in “Low noise mode”
- Input signal: Off in normal operation
- To set the level of “Low noise mode”, refer to “[Low noise mode](#)” on page 126.

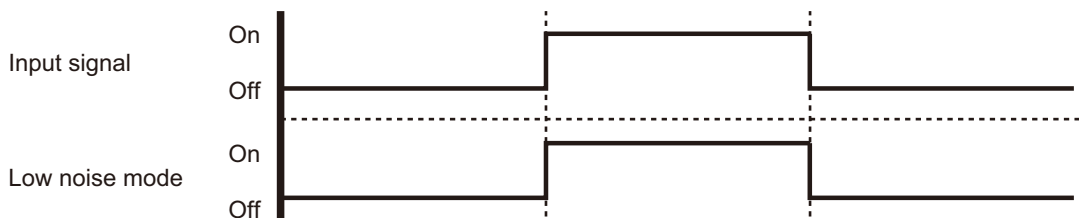

● Optional part

Part name	Model name	Exterior
External connect kit	UTY-XWZXZ3	

■ Peak cut mode

By performing following on-site work, operation that suppresses the current value can be enabled: The air conditioner is set to the “Peak cut mode” when closing the contact input of a commercial timer or on/off switch to a connector on the control PCB of the outdoor unit.

● Circuit diagram example

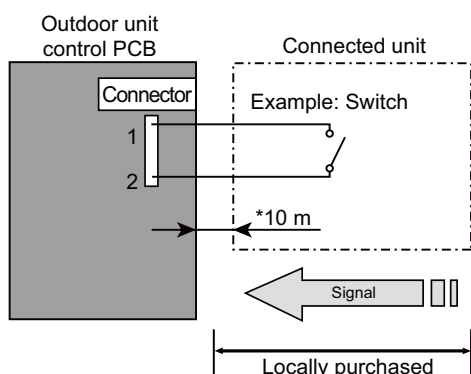

- Contact capacity: DC 24 V or more, 10 mA or more.
- *: Make the distance from the PCB to the connected unit within 10 m.
- Construct a circuit as shown in this figure with using optional parts mentioned below.
- Input signal: On in “Peak cut mode”
- Input signal: Off in normal operation
- To set the level of “Peak cut mode”, refer to [“Peak cut mode”](#) on page 127.

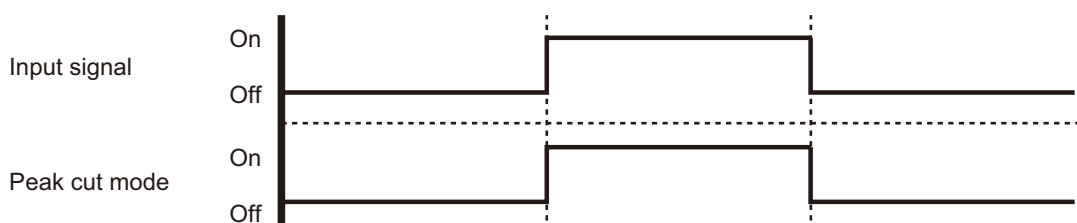

● Optional part

Part name	Model name	Exterior
External connect kit	UTY-XWZXZ3	

12-2. External output

With using external output function, some status signals are transmitted to the control PCB, and the related LED lamp indicates the status of this product.

■ Error status output

● Circuit diagram example

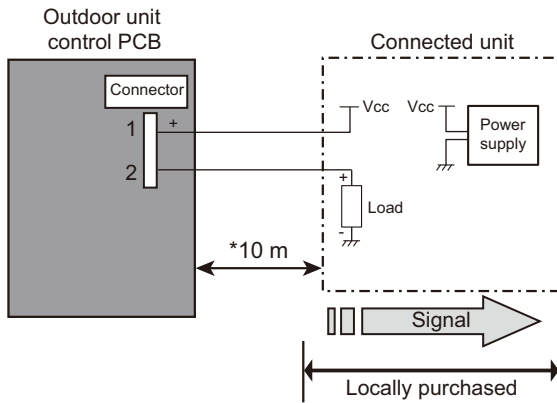

- 1: Power supply
Voltage (Vcc): DC 24 V or less
- 2: Load
DC 500 mA or less
- *: Make the distance from the PCB to the connected unit within 10 m.

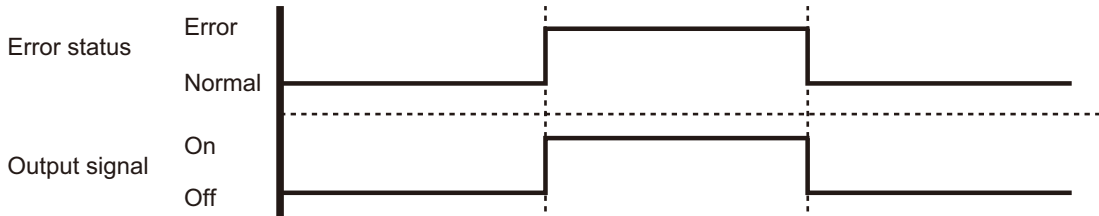

● Optional part

Part name	Model name	Exterior
External connect kit	UTY-XWZXZ3	

■ Compressor status output

● Circuit diagram example

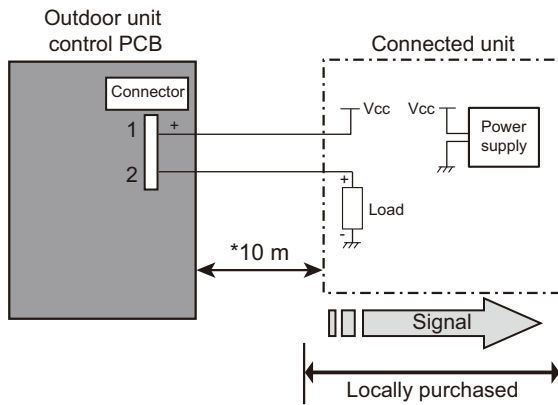

- 1: Power supply
Voltage (Vcc): DC 24 V or less
- 2: Load
DC 500 mA or less
- *: Make the distance from the PCB to the connected unit within 10 m.

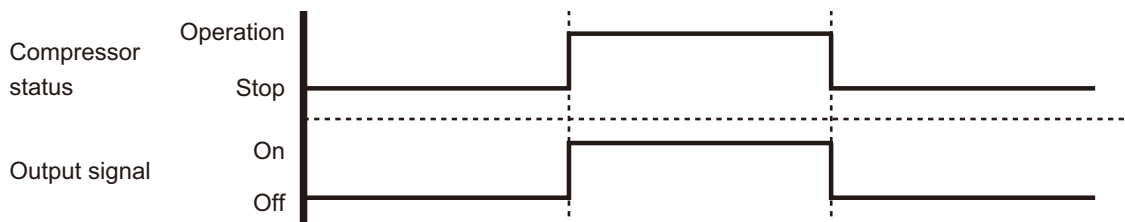

● Optional part

Part name	Model name	Exterior
External connect kit	UTY-XWZXZ3	

13. Function settings (Only for AOYG45LBTA and AOYG54LBTA)

Perform appropriate function setting locally according to the installation environment.

NOTE: Incorrect settings can cause a product malfunction.

⚠ CAUTION

- Before setting up the switch buttons, discharge the static electricity from your body.
- Never touch the terminals or the patterns on the parts that are mounted on the PCB.

13-1. Local setting switch buttons

■ Control PCB and switch buttons location

Control PCB of the outdoor unit is located as shown in the following figure.

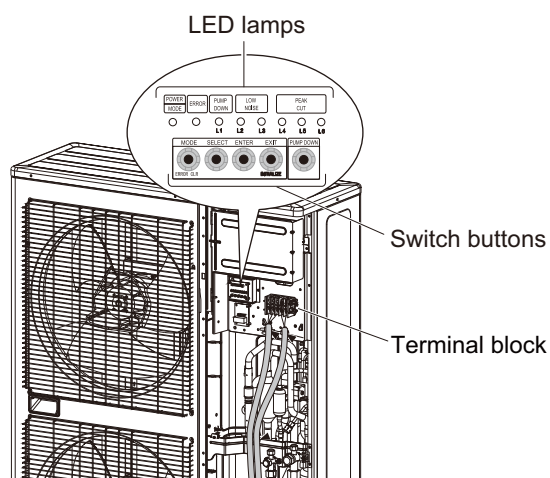

■ Switch buttons and the functions

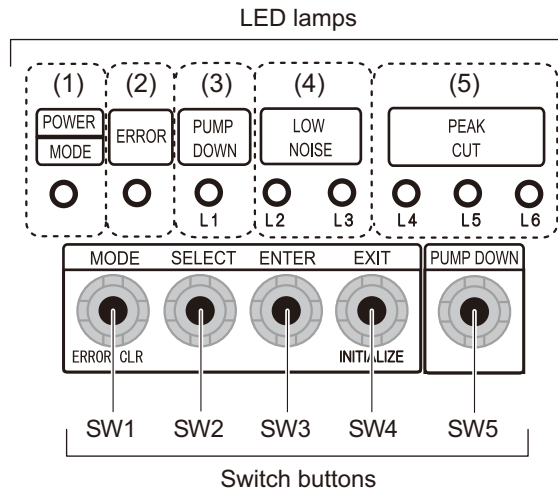

LED lamp			Function or operation method
(1)	POWER/MODE	Green	Lights on while power on. Local setting in outdoor unit or error code is displayed with blink.
(2)	ERROR	Red	Blinks during error operation.
(3)	PUMP DOWN (L1)	Orange	Lights on during pump down operation.
(4)	LOW NOISE MODE (L2 and L3)	Orange	Lights on during “Low noise mode” when local setting is activated. (Lighting pattern of L2 and L3 indicates low noise level.)
(5)	PEAK CUT MODE (L4, L5, and L6)	Orange	Lights on during “Peak cut mode” when local setting is activated. (Lighting pattern of L4, L5, and L6 indicates peak cut level.)

Switch button		Function or operation method
SW1	MODE	Switches between “Local setting” and “Error code display”.
SW2	SELECT	Switches between the individual “Local settings” and the “Error code displays”.
SW3	ENTER	Switches between the individual “Local settings” and the “Error code displays”.
SW4	EXIT	Returns to “Operation status display”.
SW5	PUMP DOWN	Starts the pump down operation.

13-2. Local setting procedure

NOTE: Before performing the function setting, be sure to stop the operation of the air conditioner.

■ Low noise mode

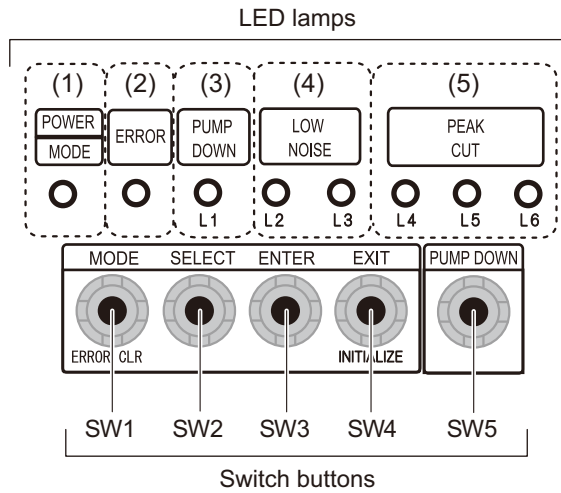

1. Press the MODE switch button (SW1) for 3 seconds or more to switch to “Local setting mode”.
2. After confirming the LED lamp of POWER/MODE blinks 9 times, press the ENTER switch button (SW3).

POWER MODE	ERROR	PUMP DOWN (L1)	LOW NOISE (L2) (L3)	PEAK CUT (L4) (L5) (L6)		
Blinks (9 times)	○	○	○ ○	○	○	○

Sign “○”: Lights off

3. Press the SELECT switch button (SW2), and adjust the LED lamp as shown below. Then the LED lamp indicates the current setting.

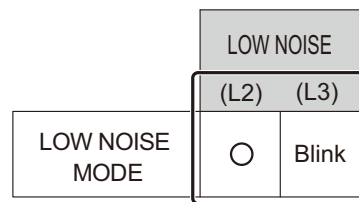

4. Press the ENTER switch button (SW3).

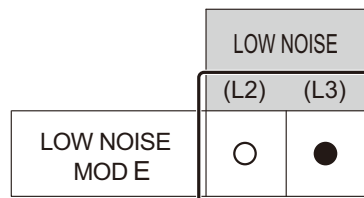

Sign “●”: Lights on

5. Press the SELECT switch button (SW2), and adjust the LED lamps as shown below.

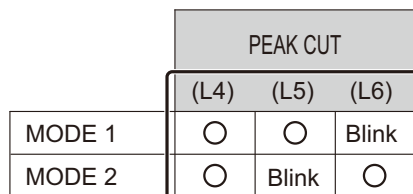

- Press the ENTER switch button (SW3) and fix it.

	PEAK CUT		
	(L4)	(L5)	(L6)
MODE 1	○	○	●
MODE 2	○	●	○

- To return to “Operating status display (Normal operation)”, press the EXIT switch button (SW4).

In case of missing how many times you pressed the SELECT and ENTER switch buttons:

- To return to “Operation status display (Normal operation)”, press the EXIT switch button once.
- Restart from the beginning of setting procedure.

NOTE: In case of missing how many times you pressed the SELECT and ENTER switch buttons, you must redo the setting procedure. Return to “Operation status display (Normal operation)” by pressing the EXIT switch button once, and restart from the beginning of the setting procedure.

■ Peak cut mode

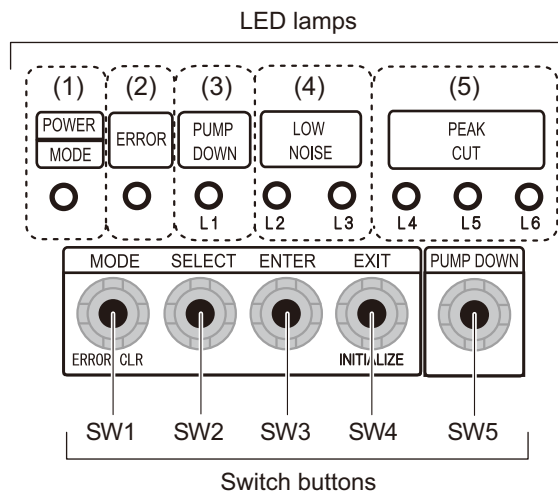

- Press the MODE switch button (SW1) for 3 seconds or more to switch to “Local setting mode”.
- After confirming the LED lamp of POWER/MODE blinks 9 times, press the ENTER switch button (SW3).

POWER	ERROR	PUMP DOWN	LOW NOISE		PEAK CUT		
MODE		(L1)	(L2)	(L3)	(L4)	(L5)	(L6)
Blinks (9 times)	○	○	○	○	○	○	○

Sign “○”: Lights off

- Press the SELECT switch button (SW2), and adjust the LED lamp as shown below. Then the LED lamp indicates the current setting.

	LOW NOISE	
	(L2)	(L3)
PEAK CUT MODE	Blink	○

4. Press the ENTER switch button (SW3).

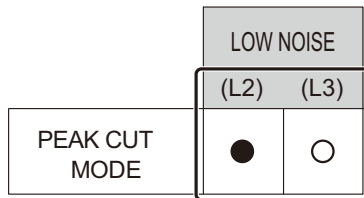

Sign "●": Lights on

5. Press the SELECT switch button (SW2), and adjust the LED lamps as shown below.

	PEAK CUT		
	(L4)	(L5)	(L6)
100 % of rated input ratio	○	○	Blink
75 % of rated input ratio	○	Blink	○
50 % of rated input ratio	○	Blink	Blink
0 % of rated input ratio	Blink	○	○

6. Press the ENTER switch button (SW3) and fix it.

	PEAK CUT		
	(L4)	(L5)	(L6)
100 % of rated input ratio	○	○	●
75 % of rated input ratio	○	●	○
50 % of rated input ratio	○	●	●
0 % of rated input ratio	●	○	○

7. To return to "Operating status display (Normal operation)", press the EXIT switch button (SW4).

NOTE: When pressed number is lost during setting, you must redo the setting procedure. Return to "Operation status display (Normal operation)" by pressing the EXIT switch button once, and restart from the beginning of the setting procedure.

14. Optional parts

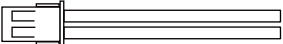
Exterior	Part name	Model name	Summary
 A technical drawing of an external connect kit, showing a rectangular connector with three horizontal slots on the left side, connected to a long, thin rectangular bar.	External connect kit	UTY-XWZXZ3	Use to operate the external input and output functions of outdoor unit. (For 45 and 54 models)